

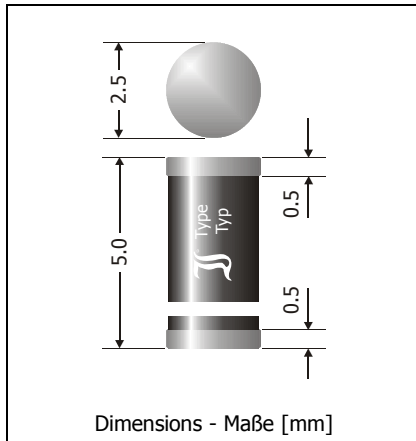

**SM4001 ... SM4007,  
SM513, SM516, SM518, SM2000**  
Surface Mount Si-Rectifiers  
Si-Gleichrichter für die Oberflächenmontage

Version 2005-08-18



Nominal current Nennstrom	1 A
Repetitive peak reverse voltage Periodische Spitzensperrspannung	50...2000 V
Plastic case MELF Kunststoffgehäuse MELF	DO-213AB
Weight approx. – Gewicht ca.	0.12 g
Plastic material has UL classification 94V-0 Gehäusematerial UL94V-0 klassifiziert	
Standard packaging taped and reeled Standard Lieferform gegurtet auf Rolle	

**Maximum ratings****Grenzwerte**

Type Typ	Repetitive peak reverse voltage Periodische Spitzensperrspannung $V_{RRM}$ [V]	Surge peak reverse voltage Stoßspitzensperrspannung $V_{RSM}$ [V]
SM4001	50	50
SM4002	100	100
SM4003	200	200
SM4004	400	400
SM4005	600	600
SM4006	800	800
SM4007	1000	1000
SM513	1300	1300
SM516	1600	1600
SM518	1800	1800
SM2000	2000	2000

Max. average forward rectified current, R-load Dauergrenzstrom in Einwegschaltung mit R-Last	$T_T = 75^\circ\text{C}$ $T_T = 100^\circ\text{C}$	$I_{FAV}$	1 A 0.8 A
Repetitive peak forward current Periodischer Spitzenstrom	$f > 15\text{ Hz}$	$I_{FRM}$	10 A <sup>1)</sup>
Peak forward pulse current, $t = 1\text{ ms}$ Max. zulässiger Stromimpuls, $t = 1\text{ ms}$	$T_A = 85^\circ\text{C}$	$I_{FSM}$	100 A

1 Mounted on P.C. board with 25 mm<sup>2</sup> copper pads at each terminal  
Montage auf Leiterplatte mit 25 mm<sup>2</sup> Kupferbelag (Lötpad) an jedem Anschluss

**Maximum ratings**
**Grenzwerte**

Peak forward surge current, 50/60 Hz half sine-wave Stoßstrom für eine 50/60 Hz Sinus-Halbwellen	$T_A = 25^\circ\text{C}$	$I_{FSM}$	40/44 A <sup>1)</sup>
Rating for fusing, $t < 10$ ms Grenzlastintegral, $t < 10$ ms	$T_A = 25^\circ\text{C}$	$i^2t$	8 A <sup>2</sup> s
Junction temperature – Sperrschichttemperatur Storage temperature – Lagerungstemperatur		$T_j$ $T_s$	-50...+175°C -50...+175°C

**Characteristics**
**Kennwerte**

Forward voltage Durchlass-Spannung	$T_j = 25^\circ\text{C}$	$I_F = 1$ A	$V_F$	< 1.1 V
Leakage current Sperrstrom	$T_j = 25^\circ\text{C}$ $T_j = 100^\circ\text{C}$	$V_R = V_{RRM}$ $V_R = V_{RRM}$	$I_R$ $I_R$	< 5 $\mu\text{A}$ < 50 $\mu\text{A}$
Thermal resistance junction to ambient air Wärmewiderstand Sperrschicht – umgebende Luft			$R_{thA}$	< 45 K/W <sup>1)</sup>
Thermal resistance junction to terminal Wärmewiderstand Sperrschicht – Anschluss			$R_{thT}$	< 10 K/W

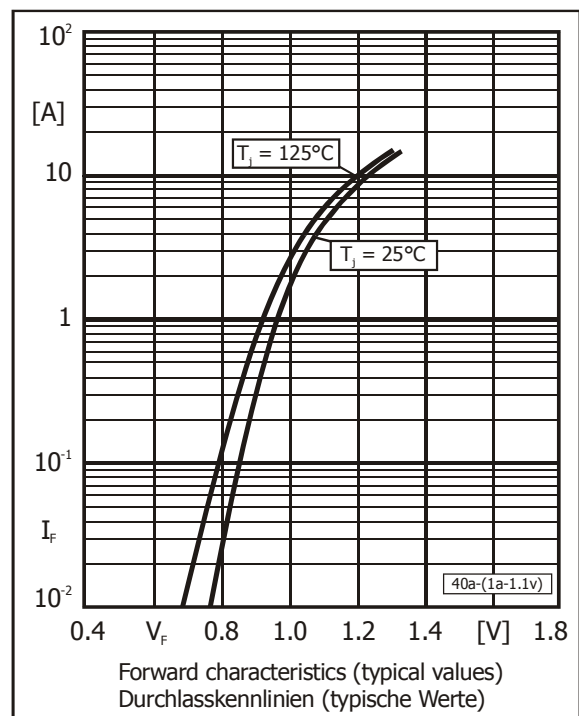
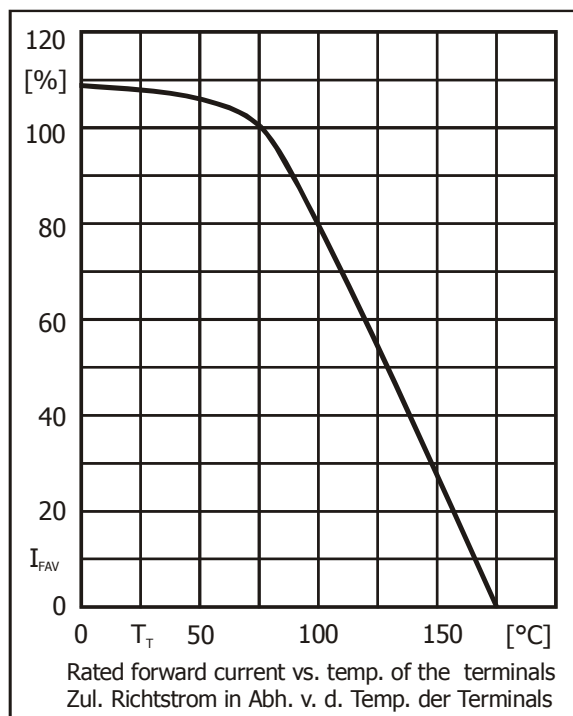

1 Mounted on P.C. board with 25 mm<sup>2</sup> copper pads at each terminal  
Montage auf Leiterplatte mit 25 mm<sup>2</sup> Kupferbelag (Löt-pad) an jedem Anschluss