



# PACKAGING

## MINIMUM ORDER QUANTITY

Please order by units of minimum order quantity.

### ◆SURFACE MOUNT

#### ●Horizontal



Series	Case code	Quantity (pcs)
Alchip® MFS/MFA/MF/MFK MFY/MFJ NP CAP™ PX	A6	3,000
	B46, B6	3,000
	C46, C6	2,500
	D46, D6, D8, D80, D10, D13	2,500
	H15, H20, H25	500

#### ●Vertical



Series	Case code	Quantity (pcs)	
		Taping	Tray
Alchip® MVS/MVA/MV/ MVK/MVY/MVJ MVH/MVE/MVL MKA/MVZ NP CAP™ PXA	B55	2,000	—
	D46, D55, D60	2,000	—
	E46, E55, E60	1,000	—
	F46, F55, F60	1,000	—
	F80	900	—
	H63, H70	1,000	—
	H10	500	—
	J80, J10	500	—
	K14	200	120
	K16	150	120
	L17, L22	*	80
	M17, M22	*	60

\* Regarding to taping for L17/L22/M17/M22, please consult us.

### ◆RADIAL



Size	Quantity (pcs)	
	Bulk	Taping
φ3 (φ3.5)	200	3,000
φ4	200	2,000
φ5	200	2,000
φ6.3	200	2,000
φ8 (φ7)	200	1,000
φ10	Height ≤ 25mm	200
	Height ≥ 30mm	200
φ12.5	100	500
φ16	50	250
φ18	50	250

\* The quantity of bulk is a typical example.

### ◆SNAP-INS



200 pieces

TAPING SPECIFICATIONS  
SURFACE MOUNT TYPE (TAPING)



◆CARRIER TAPE [mm]

Fig.1

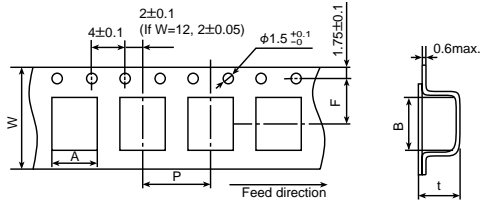

Fig.2

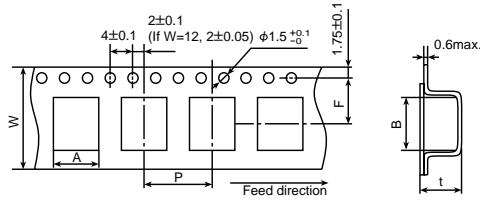

Fig.3

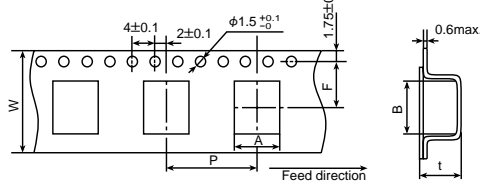

Fig.4

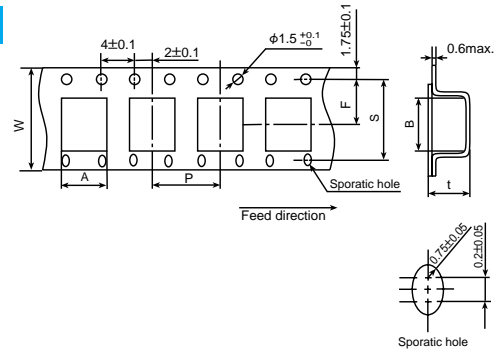
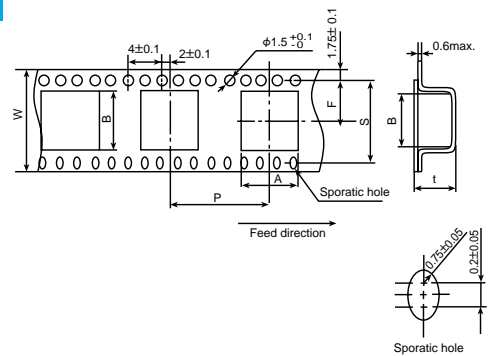

Fig.5



[mm]

Items		W	A	B	F	P	t	S	Fig.
Series		±0.3	±0.2	±0.2	±0.1	±0.1	±0.2	±0.1	
Alchip® MFS/MFA MF/MFK MFY/MFJ NP CAP™ PX	A6	12.0	3.7	6.7	5.5	8.0	3.5	—	1
	B46	12.0	4.2	5.2	5.5	8.0	4.0	—	1
	B6	12.0	4.2	6.7	5.5	8.0	4.0	—	1
	C46	12.0	4.7	5.2	5.5	8.0	4.5	—	1
	C6	12.0	4.7	6.7	5.5	8.0	4.5	—	1
	D46	12.0	5.2	5.2	5.5	8.0	5.0	—	1
	D6	12.0	5.2	6.7	5.5	8.0	5.0	—	1
	D8 (D80)	16.0	5.2	8.7	7.5	8.0	5.0	—	1
	D10	16.0	5.2	10.7	7.5	8.0	5.0	—	1
	D13	24.0	5.2	13.7	11.5	8.0	5.0	—	1
	H15	24.0	9.2	17.3	11.5	16.0	9.9	—	3
	H20	32.0	9.2	21.8	14.2	16.0	9.9	28.4	4
H25	44.0	9.2	26.8	20.2	16.0	9.9	40.4	4	
Alchip® MVS/MVA MVE/MV MVK/MVH MVJ/MVH MVL/MKA MVZ NP CAP™ PXA	B55	12.0	3.5	3.5	5.5	8.0	5.9	—	1
	D46	12.0	4.7	4.7	5.5	8.0	4.9	—	1
	D55	12.0	4.7	4.7	5.5	8.0	5.7	—	1
	D60	12.0	4.7	4.7	5.5	8.0	6.3	—	1
	E46	12.0	5.7	5.7	5.5	12.0	4.9	—	2
	E55	12.0	5.7	5.7	5.5	12.0	5.7	—	2
	E60	12.0	5.7	5.7	5.5	12.0	6.3	—	2
	F46	16.0	7.0	7.0	7.5	12.0	4.9	—	2
	F55	16.0	7.0	7.0	7.5	12.0	5.7	—	2
	F60	16.0	7.0	7.0	7.5	12.0	6.3	—	2
	F80	16.0	7.0	7.0	7.5	12.0	8.2	—	2
	H63	16.0	8.7	8.7	7.5	12.0	6.8	—	2
	H70	24.0	8.7	8.7	11.5	12.0	7.2	—	2
	H10	24.0	8.7	8.7	11.5	16.0	11.0	—	3
	J80	24.0	10.7	10.7	11.5	16.0	8.2	—	3
	J10	24.0	10.7	10.7	11.5	16.0	11.0	—	3
K14	32.0	13.4	13.4	14.2	24.0	14.0	28.4	5	
K16	32.0	13.4	13.4	14.2	24.0	16.5	28.4	5	

\* Regarding to taping for L17/L22/M17/M22, please consult us.

◆ REEL DIMENSIONS [mm]

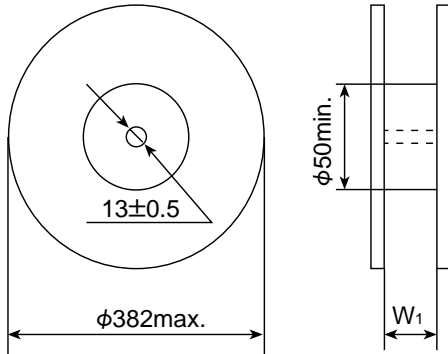

◆ QUANTITY PER REEL/BOX

Series	Case code	Quantity (pcs/reel)	Quantity (pcs/box)	W <sub>1</sub> (mm)	
Alchip <sup>®</sup> MFS/MFA/MF MFK/MFY/MFJ	A6	3,000	15,000	14	
	B46, B6	3,000	15,000	14	
	C46, C6	2,500	12,500	14	
	D46, D6	2,500	12,500	14	
	D8, D80, D10	2,500	12,500	18	
	D13	2,500	7,500	26	
	NP CAP <sup>™</sup> PX	H15	500	1,500	26
		H20	500	1,000	34
H25		500	1,000	46	
Alchip <sup>®</sup> MVS/MVA MV/MVK MVY/MVJ MVH/MVE MVL/MKA		B55	2,000	10,000	14
	D46, D55, D60	2,000	10,000	14	
	E46, E55, E60	1,000	5,000	14	
	F46, F55, F60	1,000	5,000	18	
	F80	900	4,500	18	
	H63	1,000	5,000	18	
	H70	1,000	3,000	26	
	NP CAP <sup>™</sup> PXA	H10	500	1,500	26
		J80, J10	500	1,500	26
		K14	200	600	34
		K16	150	450	34

◆ POLARITY

Alchip<sup>®</sup> MFS/MFA/MF  
(Horizontal) MFK/MFY/MFJ  
NP CAP<sup>™</sup> PX

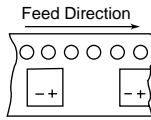

Alchip<sup>®</sup> MVS/MV/MVK  
(Vertical) MVY/MVJ/MVH/  
MVE/MVL/MKA/  
MVZ  
NP CAP<sup>™</sup> PXA

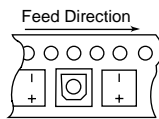

SURFACE MOUNT TYPE (TRAY)

◆ DIMENSIONS [mm]

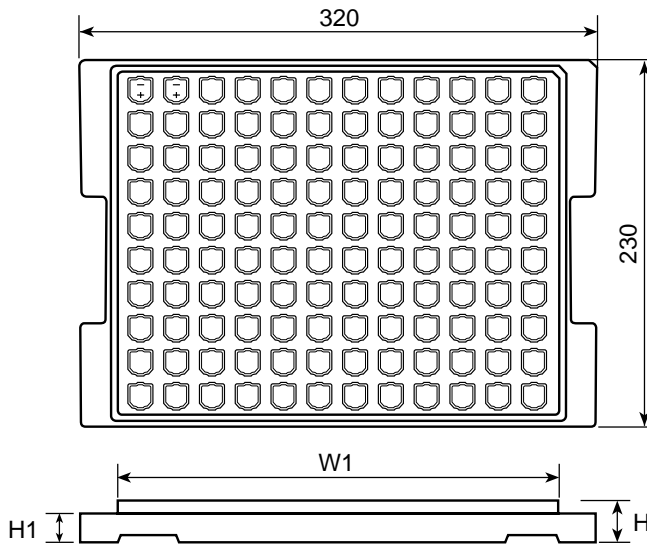

Case code	H [mm]	W <sub>1</sub> [mm]	H <sub>1</sub> [mm]
K14 & K16	21.0	284	18.5
L17 & L22	28.0	284	24.0
M17 & M22	28.0	284	24.0

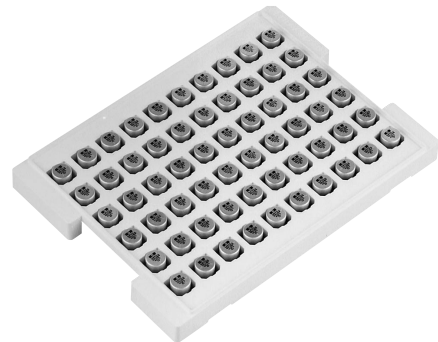

◆ QUANTITY PER TRAY

Case code	Quantity (pcs/tray)	Quantity (pcs/box)
K14 & K16	120	600
L17 & L22	80	400
M17 & M22	60	300

◆ TRAY CODE

Example

**Capacitor's D/N TR**  
MVE6.3VC 4700M L22TR

TAPING SPECIFICATIONS  
RADIAL LEAD TYPE (TAPING)



◆CARRIER TAPE [mm]

Fig.1

φD=φ3 to 8

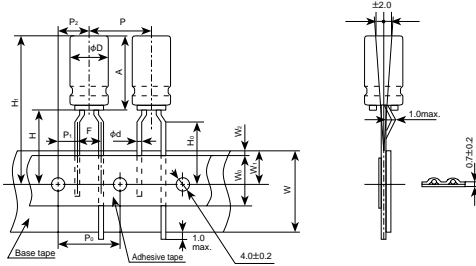

Fig.2

φD=φ5  
φD×L=φ4×7

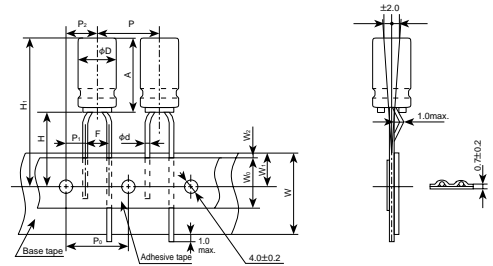

Fig.3

φD=φ6.3 to 8  
φD=φ10 & 12.5

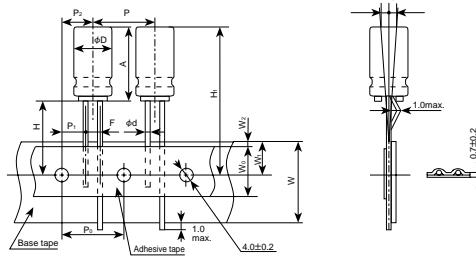
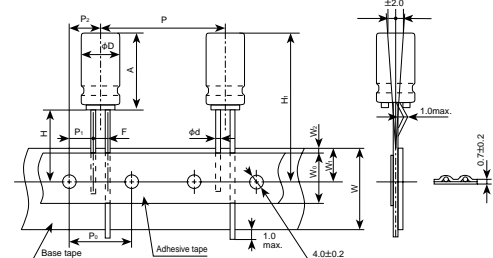

Fig.4

φD=φ12.5



Code	Case size		φd	P	P <sub>0</sub>	P <sub>1</sub>	P <sub>2</sub>	F	W	W <sub>0</sub>	W <sub>1</sub>	W <sub>2</sub>	H	H <sub>0</sub>	H <sub>1</sub>	Fig.	Taping code
	φD	A															
tol.	—	—	±0.05	±1.0	±0.2	±0.7	±1.0	+0.8 -0.2	±0.5	min.	±0.5	max.	±0.75	±0.5			
Nominal	3	5	0.4	12.7	12.7	5.1	6.35	2.5	18.0	6.0	9.0	1.5	17.5	16.0		1	TC04R F25
																1	TC04R F25
	4	5 to 7	0.45	12.7	12.7	5.1	6.35	2.5	18.0	6.0	9.0	1.5	17.5	16.0		2	TD04R F25
																1	TC04R F50
	5	5 to 7	0.45	12.7	12.7	5.1	6.35	2.5	18.0	6.0	9.0	1.5	17.5	16.0		1	TC04R F25
																2	TD04R F25
	6.3	5 to 7	0.45	12.7	12.7	5.1	6.35	2.5	18.0	6.0	9.0	1.5	17.5	16.0		1	TC04R F50
																2	TD04R F25
	7	5 to 7	0.5	12.7	12.7	5.1	6.35	2.5	18.0	6.0	9.0	1.5	18.5	16.0		1	TC04R F50
																2	TD04R F25
	8	5 to 7	0.45	12.7	12.7	5.1	6.35	2.5	18.0	6.0	9.0	1.5	17.5	16.0		3	TD04R F25
																1	TC04R F50
8	5 to 7	0.5	12.7	12.7	5.1	6.35	2.5	18.0	6.0	9.0	1.5	17.5	16.0		3	TD04R F25	
															1	TC04R F50	
8	7 to 15	0.5	12.7	12.7	5.1	6.35	2.5	18.0	6.0	9.0	1.5	18.5	16.0		3	TD04R F25	
															1	TC04R F50	
8	7 to 15	0.5	12.7	12.7	5.1	6.35	2.5	18.0	6.0	9.0	1.5	17.5	16.0		3	TD04R F25	
															1	TC04R F50	
8	9 to 20	0.6	12.7	12.7	3.85	6.35	5	18.0	10.0	9.0	1.5	20.0	16.0		1	TC04R F50	
															1	TC04R F50	
tol.	±0.5	max.	±0.05	±1.0	±0.3	±0.7	±1.3	+0.8 -0.2	±0.5	min.	±0.5	max.	+2.0 -0	—			
Nominal	10	21	0.6	12.7	12.7	3.85	6.35	5	18.0	12.5	9.0	1.5	18.0	—		3	TD04R F50 H18
																3	TD03R F50 H18
Nominal	12.5	26	0.6	25.4	12.7	3.85	6.35	5	18.0	12.5	9.0	1.5	18.0	—		4	TD05R F50 H18

Check insertion machine specs.  
H1=H+A

\* 1 : For φ4×7 (A=7, F=25), shall be 18.5<sup>-0.5/+0.75</sup> (code : TD04R F25) at Fig.2.

\* 2 : P=15 taping is not standard. Use P=25.4 taping.

TAPING CODE

Example

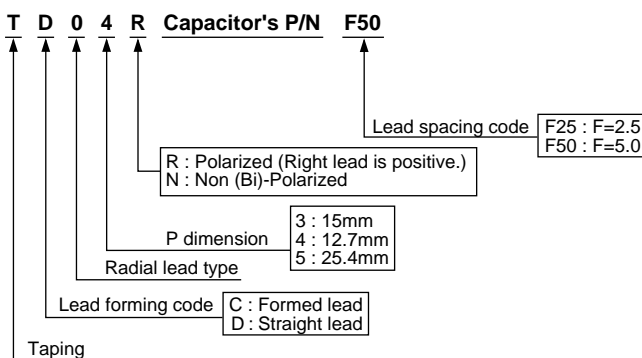

QUANTITY PER AMMO PACK

Ammo pack box

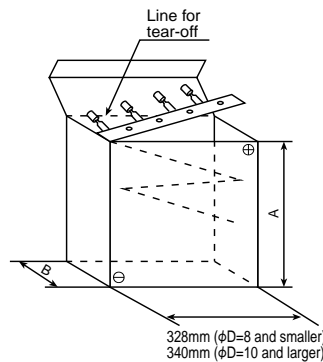

Typical example

Case size φD × L (mm)	A (mm)	B (mm)	Quantity (pcs.)
φ3	216	42	3,000
φ3.5	216	42	3,000
φ4	L=5 & 7mm	183	42
	L=11.5mm	183	51
φ5	L=5 & 7mm	232	42
	L=9 to 15mm	232	51
φ6.3	L=17mm	235	53
	L=5 & 7mm	282	42
φ7	L=9 to 15mm	284	51
	L=17mm	284	55
φ8	L=5 & 7mm	183	42
	L=9 to 15mm	232	51
φ10	L=17 & 20mm	235	53
	L≤25mm	308	62
φ12.5	L≥30mm	308	67
		308	67

\* Regarding to taping specifications for PS series, please consult us.

## RADIAL LEAD TYPE (CUT/FORMED LEAD)

The following lead configurations are available upon request. When ordering, please indicate the type of lead configurations by using the appropriate supplement code, such as C5, FC, MC or RC in the product part number.

[mm]

### ●Lead Configuration : C5

$\phi D=3$  to 18

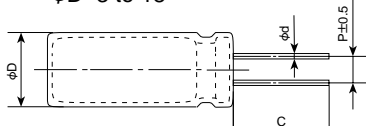

Case diameter C:Lead length

$\phi D=3$  to 8 :  $5.0 \pm 0.5$

$\phi D=10$  to 18 :  $5.0^{+1.0}_0$

### ●Lead Configuration : C3.5

$\phi D=3$  to 18

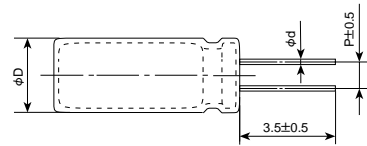

### ●Lead Configuration : FC

$\phi D=5$  to 8

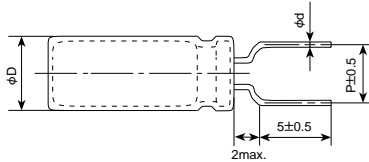

### ●Lead Configuration : FM

$\phi D=5$  to 8

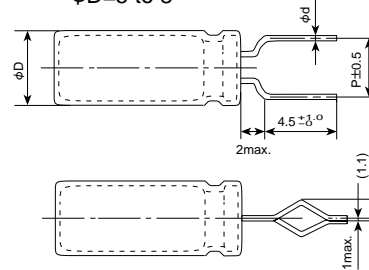

### ●Lead Configuration : MC

$\phi D=10$  to 18

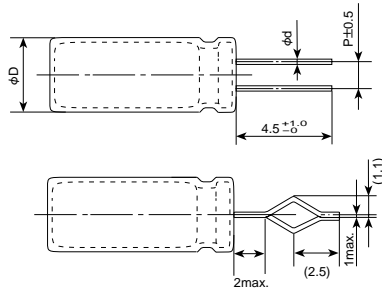

### ●Lead Configuration : RC

$\phi D=20$  & 22

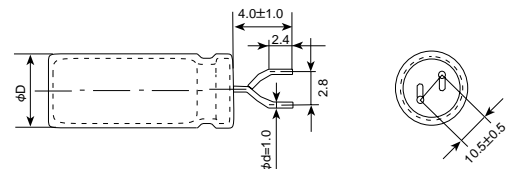

\* Regarding to cut/formed lead for PS series, please consult us.