

Compact, High Isolation Relay

- Compact single pole relay with high isolation between coil and contacts
- Up to 10 A switching on the NO contacts
- Ensures a withstand impulse voltage of 8,000 V between the coil and contacts
- Low coil power consumption
- UL class F coil insulation
- UL, CSA, and VDE approvals
- Ideal for appliance and HVAC controls



Ordering Information

To Order: Select the part number and add the desired coil voltage rating, (e.g., G5Q-14-DC12)

Classification		Enclosure rating	Part number
Single contact, class F coil	SPST-NO	Vented	G5Q-1A
		Sealed	G5Q-1A4
	SPDT	Vented	G5Q-1
		Sealed	G5Q-14

Specifications

■ COIL RATINGS

Rated voltage (V)		Rated coil current (mA)	Coil resistance (Ω)	Pick-up voltage	Drop-out voltage	Maximum voltage	Power consumption (mW)
SPDT	DC 5	80	63	75% of max.	5% of max.	190% @ 23°C	400
	DC 12	33.3	360				
	DC 24	16.7	1440				
SPST-NO	DC 5	40	125	75% of max.	5% of max.	190% @ 23°C	200
	DC 12	16.7	720				
	DC 24	8.3	2880				

Note: Rated current and coil resistance are measured at 23°C with a tolerance of ±10%.

CONTACT RATINGS

Load	SPDT	SPST-NO
Rated load (resistive)	10 A @ 125 VAC (NO) 3 A @ 250 VAC (NO) 5 A @ 30 VDC (NO) 3 A @ 125 VAC (NC) 3 A @ 30 VDC (NC)	10 A @ 125 VAC 3 A @ 250 VAC 5 A @ 30 VDC
Contact material	Ag Alloy	
Rated carry current	10 A (NO)/3 A (NC)	
Max. switching voltage	277 VAC, 30 VDC	
Max. switching current	AC: 10 A (NO)/3 A (NC) DC: 5 A (NC)/3 A (NC)	
Max. switching capacity	1250 VA, 150 W (NO) 375 VA, 90 W (NC)	
Min. permissible load	10 mA at 5 VDC (P level: $\lambda 60=0.1 \times 10^{-6}$ operation)	

CHARACTERISTICS

Contact resistance (See Note 2.)	100 m Ω max.	
Operate time	10 ms max.	
Release time	5 ms max.	
Insulation resistance (See Note 3.)	1,000 M Ω min.	
Dielectric strength	4,000 VAC, 50/60 Hz for 1 min between coil and contacts 1000 VAC, 50/60 Hz for 1 min between contacts of same polarity	
Impulse withstand voltage	8 kV (1.2 x 50 μ s) between coil and contacts	
Vibration resistance	Destruction: 10 to 55 Hz, 1.5-mm double amplitude for 2 hours Malfunction: 10 to 55 Hz, 1.5-mm double amplitude for 5 minutes	
Shock resistance	Destruction: 1,000 m/s ² (approx. 100G) Malfunction: 100 m/s ² (approximately 10G)	
Life expectancy (See Note 4.)	Mechanical	10,000,000 operations (18,000 operations per hour)
	Electrical	200,000 operations: 3 A (NO)/3 A (NC) at 125-VAC resistive load 100,000 operations: 3 A (NO)/3 A (NC) at 250 VAC 5 A (NO)/3 A (NC) at 30-VDC resistive load 50,000 operations: 10 A (NO) at 125-VAC (900 operations per hour)
	Switching frequency	1,800 operations per hour
Ambient temperature	Operating & storage	-40°C to 105°C (-40°F to 221°F) with no freezing or condensation
Ambient humidity	Operating & storage	5% to 85%

Note: 1. The data shown above are initial values.

2. The contact resistance is possible with 1 A applied at 5 VDC using a fall-of-potential method.

3. The insulation resistance is possible between coil and contacts and between contacts of the same polarity at 500 VDC.

4. The electrical life data items shown are possible at 23°C.

■ APPROVED STANDARDS

UL508 (File No. E41515)

CSA C22.2 No. 14 (File No. LR31928)

Model	Coil ratings	Contact ratings (See Note)	
		NO contacts	NC contacts
G5Q	5-48 VDC	10 A, 250 VAC resistive 10 A, 30 VDC resistive 4 A, 120 VAC resistive, 100,000 ops. 4 FLA, 4 LRA 120 VAC, definite purpose, 100,000 operations.	3 A, 250 VAC resistive 3 A, 30 VDC resistive 4 LRA, 2 FLA, 120 VAC definite purpose, 100,000 operations.

Note: Ratings for both NO contacts and NC contacts are given at 105°C (221°F).

VDE (Reg. No. 125314)

Model	Coil ratings	Contact ratings
G5Q	5, 12, 24 VDC	10 A, 250 VAC $\cos\phi=1$ (NO) 5 A, 30 VDC L/R=0ms (NO) 3 A, 30 VDC L/R=0ms (NC)

Engineering Data

■ AMBIENT TEMPERATURE VS. MAXIMUM VOLTAGE

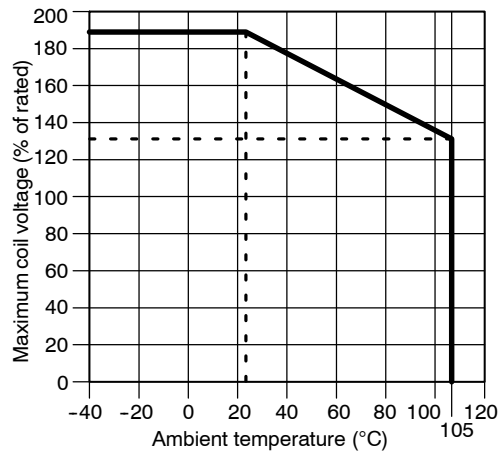

■ AMBIENT TEMPERATURE VS. RATED CARRY CURRENT

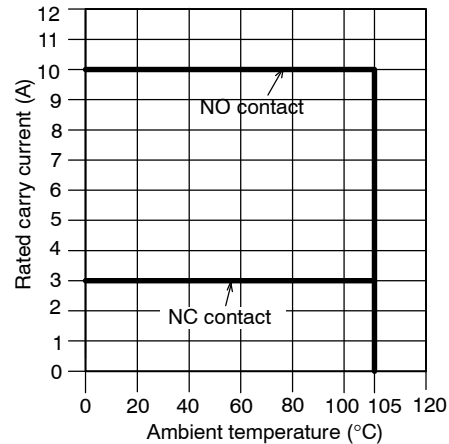

■ MAX. SWITCHING CAPACITY

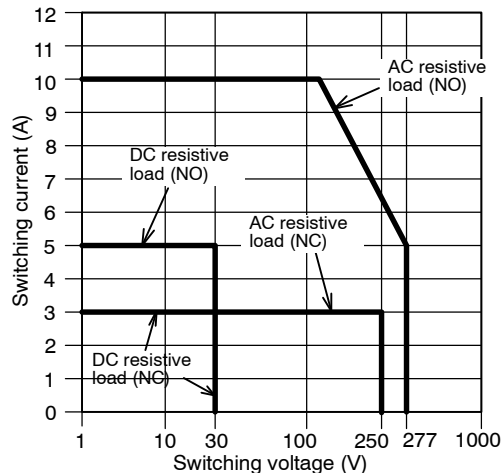

Dimensions

Unit: mm (inch)

■ G5Q SPDT

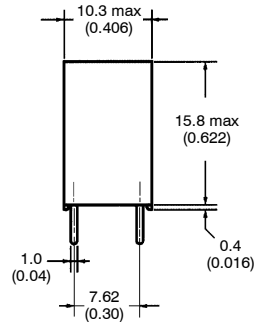
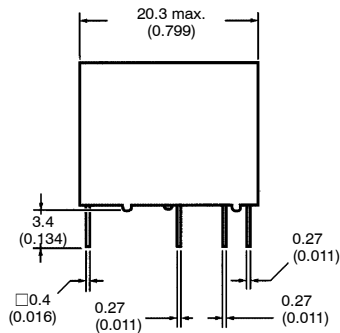

PCB Mounting Holes
(Bottom View)
Tolerance: ± 0.1 mm

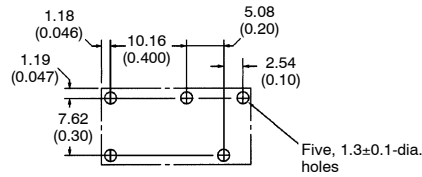

Terminal Arrangement/
Internal Connections
(Bottom View)

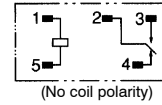

■ SPST-NO

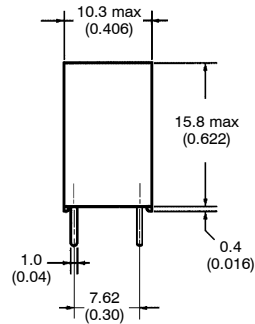
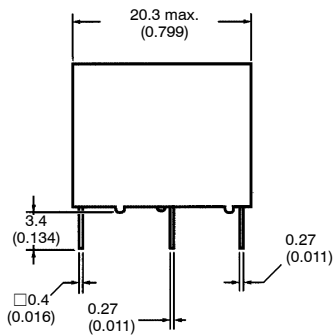

PCB Mounting Holes
(Bottom View)
Tolerance: ± 0.1 mm

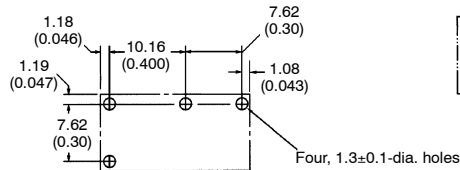

Terminal Arrangement/
Internal Connections
(Bottom View)

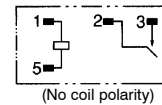

Precautions

For general precautions on PCB Relays, refer to the precautions provided in *General Information* of the *Relay Product Data Book*.

⚠ Caution

Do not touch the terminals of the Relay or the charted part of the socket when power is supplied to the Relay. Otherwise, an electric shock may occur.

NOTE: DIMENSIONS SHOWN ARE IN MILLIMETERS. To convert millimeters to inches divide by 25.4.

OMRON®

OMRON ELECTRONICS, INC.

One East Commerce Drive
Schaumburg, IL 60173

1-800-55-OMRON

OMRON CANADA, INC.

885 Milner Avenue
Scarborough, Ontario M1B 5V8

416-286-6465