

700 SERIES

DUAL-IN-LINE Reed Relays

- transfer molded relays in IC style packages
- designed for automatic insertion into IC-sockets or PC boards

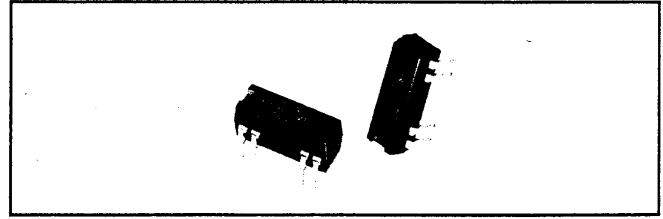

Dimensions (in mm, () = in inches)

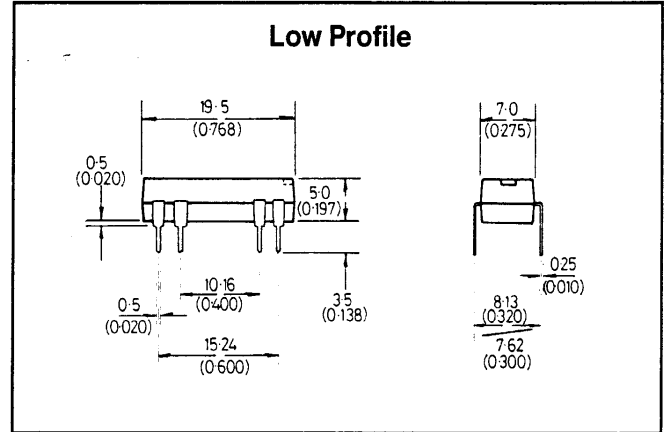
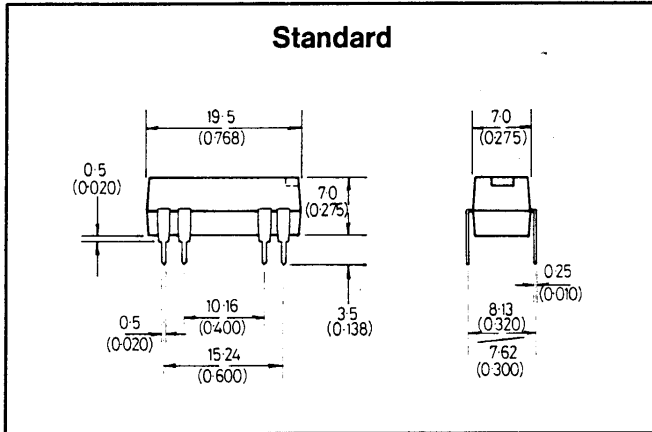

General Specifications

Electrical Data

Voltage Hold-off (at 50 Hz, 23° C, 40% RH)	
coil to contact	500 V d.c.
(for relays with contact type 5, spare pins removed)	2500 V d.c.)
coil to electrostatic shield	150 V d.c.
between all other mutually insulated terminals	500 V d.c.
Insulation resistance (at 23° C, 40% RH)	
coil to contact	10 ¹⁰ Ω min. (at 100 V d.c.)

Mechanical Data

Shock	50 g (11 ms) 1/2 sine wave (for Hg-wetted contacts) 5 g (11 ms) 1/2 sine wave
Vibration	20 g (10 – 2000 Hz) (for Hg-wetted contacts) consult HAMLIN office
Temperature Range	– 40 to + 85° C (for Hg-wetted contacts) – 38 to + 85° C
Drain time	30 sec. after reaching vertical position (for Hg-wetted contacts)
Mounting	any position (for Hg contacts type 3) 30° max. from vertical
Pins	tin plated, solderable, ∅ 0.6 mm (0.0236") max.

Contact Characteristics

Contact type number		2	2	3	4	5
Characteristic		Dry		Hg-wetted	Hg-wetted all position	Dry pressurized
Contact Form		A	B/C	A	A	A
Contact Rating, max.	W	10	3	50	3	10
Switching Voltage, max.	V d.c.	200	200	400	28	300
Switching Current, max.	A	0.5	0.25	2.0	0.10	0.5
Carry Current, max.	A	1.5	1.2	3.0	1.0	1.5
Min. Voltage Hold-off across contacts	V d.c.	250	250	1000	1000	800
Insulation Resistance, min.	Ω	10 ¹⁰	10 ⁹	10 ¹⁰	10 ¹⁰	10 ¹⁰
Initial Contact Resistance, max.	Ω	0.200	0.200	0.070	0.100	0.200

Operating life (in accordance with ANSI, EIA/NARM-Standard) – Number of operations

Load		2	2	3	4	5
10 mA/5 V d.c.		5 × 10 ⁷	10 ⁷	10 ⁹	10 ⁷	5 × 10 ⁷
100 mA/12 V d.c.		10 ⁷	7 × 10 ⁶	10 ⁹	5 × 10 ⁶	10 ⁷
250 mA/28 V d.c.		5 × 10 ⁶	–	10 ⁸	–	5 × 10 ⁶
1 A/28 V d.c.		–	–	4 × 10 ⁷	–	–
10 mA/220 V a.c.		–	–	4 × 10 ⁷	–	4 × 10 ⁶

4 Coil characteristics (at 23° C)

Contact form	Coil voltage V d.c.	Relay part number*	Coil resistance Ω ($\pm 10\%$)	Must operate voltage max. V d.c.	Must release voltage min. V d.c.	Operate time max. ms	Release time** max. ms
Dry contacts							
1 A Low Profile	5	HE721A04□□	500	3.80	0.8	0.5	0.5
	5	HE721A05□□	380	3.50	1.0		
	12	HE721A12□□	530	8.00	2.0		
	15	HE721A15□□	2000	11.50	3.0		
1 A Standard	5	HE721A05□□	500	3.75	0.5	0.5	0.5
	12	HE721A12□□	1000	8.00	1.0		
	24	HE721A24□□	2150	16.00	2.0		
2 A	5	HE722A05□□	200	3.75	0.5	0.5	0.5
	12	HE722A12□□	500	8.00	1.0		
	24	HE722A24□□	2150	16.00	2.0		
1 B	5	HE721B05□□	200	3.75	0.5	0.5	0.5
	12	HE721B12□□	500	8.00	1.0		
	24	HE721B24□□	2000	16.00	2.0		
1 C	5	HE721C05□□	200	3.75	0.5	1.5	1.5
	12	HE721C12□□	500	8.00	1.0		
	24	HE721C24□□	2000	16.00	2.0		

Hg-wetted contacts – 30° from vertical

1 A	5	HE731A05□□	55	3.75	0.5	2.0	2.0
	12	HE731A12□□	300	9.00	1.0		
	24	HE731A24□□	1100	18.00	2.0		

Hg-wetted contacts – all position

1 A	5	HE741A05□□	55	3.75	0.5	3.0	3.0
	12	HE741A12□□	300	9.00	1.0		
	24	HE741A24□□	1150	18.00	2.0		

High voltage hold-off contacts

1 A	5	HE751A05□□	500	3.75	0.5	0.5	0.5
	12	HE751A12□□	1000	8.00	1.0		
	24	HE751A24□□	2150	16.00	2.0		

* Please specify the missing digits □ of relay part number as shown in the ordering guide.

** Release time will be increased with diode option.

Note: Electrostatic shield not available on low profile versions.

On most types magnetic shield option is available. For details contact HAMLIN sales office.

5 Connections (viewed from above) – 2.54 mm (0.1") grid

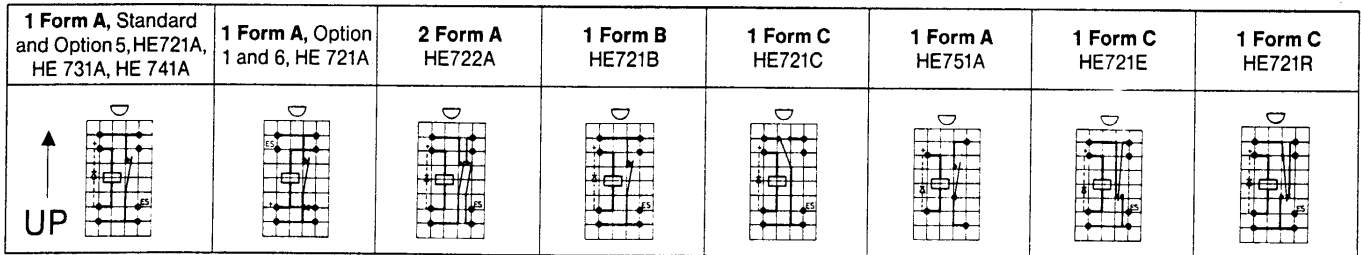

UP indicates mounting position for relays with Hg-wetted contact type 3.

ES = indicates pin for electrostatic shield

6 Ordering guide

Cont. type number	Number of contacts	Contact form	Nominal voltage	Package version	Pin configuration
2, 3, 4, 5	1 – 2	A = Form A B = Form B C = Form C E = Form C common pin: 14 R = Form C common pin: 1	04* = 5 V d.c. 500 Ω coil 05 = 5 V d.c. 12 = 12 V d.c. 24 = 24 V d.c.	0 = standard 1 = with diode 2 = with electrostatic shield 3 = with diode and electrostatic shield	0 = High profile, standard wiring 1 = High profile Option 1 wiring 5 = Low profile Option 5 wiring 6 = Low profile Option 6 wiring

* This code is only valid for low profile version (option 5 and 6).