

8-INPUT NAND GATE

FEATURES

- Output capability: standard
- I_{CC} category: SSI

GENERAL DESCRIPTION

The 74HC/HCT30 are high-speed Si-gate CMOS devices and are pin compatible with low power Schottky TTL (LSTTL). They are specified in compliance with JEDEC standard no. 7A.

The 74HC/HCT30 provide the 8-input NAND function.

SYMBOL	PARAMETER	CONDITIONS	TYPICAL		UNIT
			HC	HCT	
t _{PHL} / t _{PLH}	propagation delay A, B, C, D, E, F, G, H to Y	C _L = 15 pF V _{CC} = 5 V	12	12	ns
C _I	input capacitance		3.5	3.5	pF
C _{PD}	power dissipation capacitance per gate	notes 1 and 2	15	15	pF

GND = 0 V; T_{amb} = 25 °C; t_r = t_f = 6 ns

Notes

1. C_{PD} is used to determine the dynamic power dissipation (P_D in μW):

$$P_D = C_{PD} \times V_{CC}^2 \times f_i + \sum (C_L \times V_{CC}^2 \times f_o)$$
 where:
 f_i = input frequency in MHz C_L = output load capacitance in pF
 f_o = output frequency in MHz V_{CC} = supply voltage in V
 Σ (C_L × V_{CC}² × f_o) = sum of outputs
2. For HC the condition is V_I = GND to V_{CC}
 For HCT the condition is V_I = GND to V_{CC} - 1.5 V

PACKAGE OUTLINES

- 14-lead DIL; plastic (SOT27).
- 14-lead mini-pack; plastic (SO14; SOT108A).

PIN DESCRIPTION

PIN NO.	SYMBOL	NAME AND FUNCTION
1	A	data input
2	B	data input
3	C	data input
4	D	data input
5	E	data input
6	F	data input
7	GND	ground (0 V)
8	Y	data output
9, 10, 13	n.c.	not connected
11	G	data input
12	H	data input
14	V _{CC}	positive supply voltage

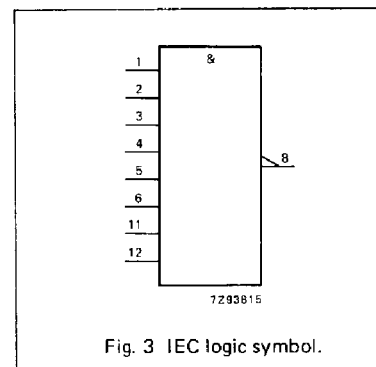
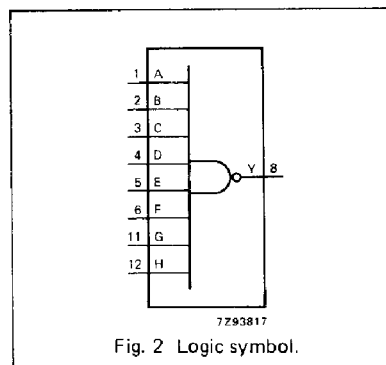
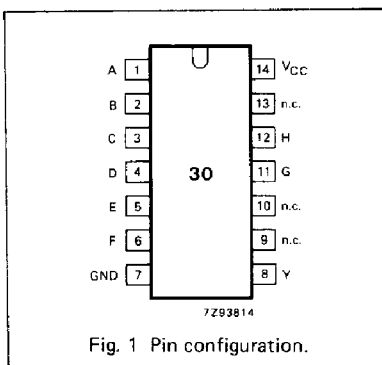

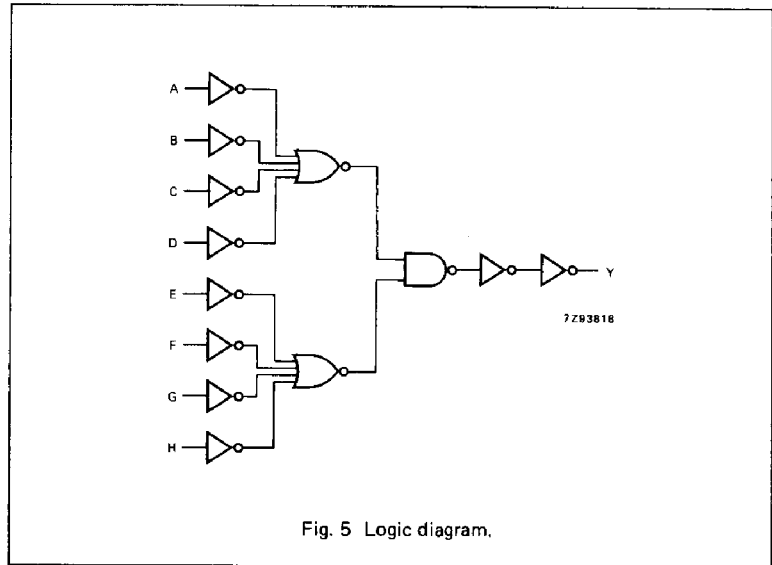
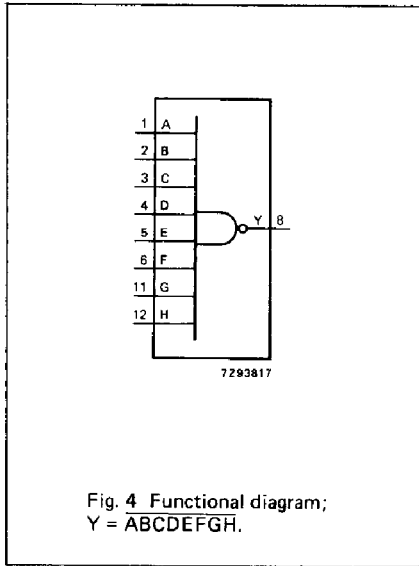

FUNCTION TABLE

INPUTS								OUTPUT
A	B	C	D	E	F	G	H	Y
L	X	X	X	X	X	X	X	H
X	L	X	X	X	X	X	X	H
X	X	L	X	X	X	X	X	H
X	X	X	L	X	X	X	X	H
X	X	X	X	L	X	X	X	H
X	X	X	X	X	L	X	X	H
X	X	X	X	X	X	L	X	H
X	X	X	X	X	X	X	L	H
H	H	H	H	H	H	H	H	L

H = HIGH voltage level
L = LOW voltage level
X = don't care

DC CHARACTERISTICS FOR 74 HC

For the DC characteristics see chapter "HCMOS family characteristics", section "Family specifications".

Output capability: standard

I_{CC} category: SSI**AC CHARACTERISTICS FOR 74HC**GND = 0 V; t_r = t_f = 6 ns; C_L = 50 pF

SYMBOL	PARAMETER	T _{amb} (°C)								UNIT	TEST CONDITIONS	
		74HC									V _{CC} V	WAVEFORMS
		+25			-40 to +85		-40 to +125					
		min.	typ.	max.	min.	max.	min.	max.				
t _{PHL} / t _{PLH}	propagation delay A, B, C, D, E, F, G, H to Y		41 15 12	130 26 22		165 33 28		195 39 33	ns	2.0 4.5 6.0	Fig. 6	
t _{THL} / t _{TLH}	output transition time		19 7 6	75 15 13		95 19 16		110 22 19	ns	2.0 4.5 6.0	Fig. 6	

DC CHARACTERISTICS FOR 74HCT

For the DC characteristics see chapter "HCMOS family characteristics", section "Family specifications".

Output capability: standard

I_{CC} category: SSI**Note to HCT types**

The value of additional quiescent supply current (ΔI_{CC}) for a unit load of 1 is given in the family specifications. To determine ΔI_{CC} per input, multiply this value by the unit load coefficient shown in the table below.

INPUT	UNIT LOAD COEFFICIENT
A, B, C, D, E, F, G, H	0.60

AC CHARACTERISTICS FOR 74HCTGND = 0 V; t_r = t_f = 6 ns; C_L = 50 pF

SYMBOL	PARAMETER	T _{amb} (°C)								UNIT	TEST CONDITIONS	
		74HCT									V _{CC} V	WAVEFORMS
		+25			-40 to +85		-40 to +125					
		min.	typ.	max.	min.	max.	min.	max.				
t _{PHL} / t _{PLH}	propagation delay A, B, C, D, E, F, G, H to Y		16	28		35		42	ns	4.5	Fig. 6	
t _{THL} / t _{TLH}	output transition time		7	15		19		22	ns	4.5	Fig. 6	

AC WAVEFORMS

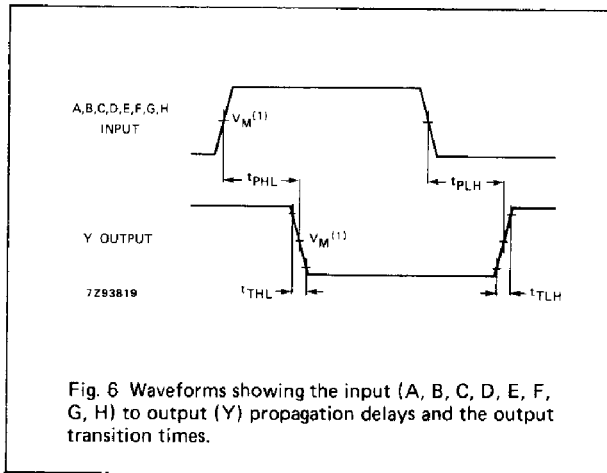

Note to AC waveforms

- (1) HC : $V_M = 50\%$; $V_I = \text{GND to } V_{CC}$.
- HCT: $V_M = 1.3 \text{ V}$; $V_I = \text{GND to } 3 \text{ V}$.