

Am29F040B

Data Sheet



July 2003

The following document specifies Spansion memory products that are now offered by both Advanced Micro Devices and Fujitsu. Although the document is marked with the name of the company that originally developed the specification, these products will be offered to customers of both AMD and Fujitsu.

Continuity of Specifications

There is no change to this datasheet as a result of offering the device as a Spansion product. Any changes that have been made are the result of normal datasheet improvement and are noted in the document revision summary, where supported. Future routine revisions will occur when appropriate, and changes will be noted in a revision summary.

Continuity of Ordering Part Numbers

AMD and Fujitsu continue to support existing part numbers beginning with "Am" and "MBM". To order these products, please use only the Ordering Part Numbers listed in this document.

For More Information

Please contact your local AMD or Fujitsu sales office for additional information about Spansion memory solutions.

Publication Number **21445** Revision **E** Amendment **I** Issue Date **October 5, 2004**





Am29F040B

4 Megabit (512 K x 8-Bit)

CMOS 5.0 Volt-only, Uniform Sector Flash Memory Distinctive Characteristics

- **5.0 V \pm 10% for read and write operations**
 - Minimizes system level power requirements
- **Manufactured on 0.32 μ m process technology**
 - Compatible with 0.5 μ m Am29F040 device
- **High performance**
 - Access times as fast as 55 ns
- **Low power consumption**
 - 20 mA typical active read current
 - 30 mA typical program/erase current
 - 1 μ A typical standby current (standard access time to active mode)
- **Flexible sector architecture**
 - 8 uniform sectors of 64 Kbytes each
 - Any combination of sectors can be erased
 - Supports full chip erase
 - Sector protection:
A hardware method of locking sectors to prevent any program or erase operations within that sector
- **Embedded Algorithms**
 - Embedded Erase algorithm automatically preprograms and erases the entire chip or any combination of designated sectors
 - Embedded Program algorithm automatically writes and verifies bytes at specified addresses
- **Minimum 1,000,000 program/erase cycles per sector guaranteed**
- **20-year data retention at 125°C**
 - Reliable operation for the life of the system
- **Package options**
 - 32-pin PLCC, TSOP, or PDIP
- **Compatible with JEDEC standards**
 - Pinout and software compatible with single-power-supply Flash standard
 - Superior inadvertent write protection
- **Data# Polling and toggle bits**
 - Provides a software method of detecting program or erase cycle completion
- **Erase Suspend/Erase Resume**
 - Suspends a sector erase operation to read data from, or program data to, a non-erasing sector, then resumes the erase operation

General Description

The Am29F040B is a 4 Mbit, 5.0 volt-only Flash memory organized as 524,288 Kbytes of 8 bits each. The 512 Kbytes of data are divided into eight sectors of 64 Kbytes each for flexible erase capability. The 8 bits of data appear on DQ0–DQ7. The Am29F040B is offered in 32-pin PLCC, TSOP, and PDIP packages. This device is designed to be programmed in-system with the standard system 5.0 volt V_{CC} supply. A 12.0 volt V_{PP} is not required for write or erase operations. The device can also be programmed in standard EPROM programmers.

This device is manufactured using AMD's 0.32 μm process technology, and offers all the features and benefits of the Am29F040, which was manufactured using 0.5 μm process technology. In addition, the Am29F040B has a second toggle bit, DQ2, and also offers the ability to program in the Erase Suspend mode.

The standard Am29F040B offers access times of 55, 70, 90, 120, and 150 ns, allowing high-speed microprocessors to operate without wait states. To eliminate bus contention the device has separate chip enable (CE#), write enable (WE#) and output enable (OE#) controls.

The device requires only a **single 5.0 volt power supply** for both read and write functions. Internally generated and regulated voltages are provided for the program and erase operations.

The device is entirely command set compatible with the **JEDEC single-power-supply Flash standard**. Commands are written to the command register using standard microprocessor write timings. Register contents serve as input to an internal state-machine that controls the erase and programming circuitry. Write cycles also internally latch addresses and data needed for the programming and erase operations. Reading data out of the device is similar to reading from other Flash or EPROM devices.

Device programming occurs by executing the program command sequence. This initiates the **Embedded Program** algorithm—an internal al-

gorithm that automatically times the program pulse widths and verifies proper cell margin.

Device erasure occurs by executing the erase command sequence. This initiates the **Embedded Erase** algorithm—an internal algorithm that automatically preprograms the array (if it is not already programmed) before executing the erase operation. During erase, the device automatically times the erase pulse widths and verifies proper cell margin.

The host system can detect whether a program or erase operation is complete by reading the DQ7 (Data# Polling) and DQ6 (toggle) **status bits**. After a program or erase cycle has been completed, the device is ready to read array data or accept another command.

The **sector erase architecture** allows memory sectors to be erased and reprogrammed without affecting the data contents of other sectors. The device is fully erased when shipped from the factory.

Hardware data protection measures include a low V_{CC} detector that automatically inhibits write operations during power transitions. The **hardware sector protection** feature disables both program and erase operations in any combination of the sectors of memory. This can be achieved via programming equipment.

The **Erase Suspend** feature enables the user to put erase on hold for any period of time to read data from, or program data to, any sector that is not selected for erasure. True background erase can thus be achieved.

The system can place the device into the **standby mode**. Power consumption is greatly reduced in this mode.

AMD's Flash technology combines years of Flash memory manufacturing experience to produce the highest levels of quality, reliability and cost effectiveness. The device electrically erases all bits within a sector simultaneously via Fowler-Nordheim tunneling. The data is programmed using hot electron injection.

Table of Contents

Product Selector Guide	6	Figure 6. Maximum Positive Overshoot Waveform	22
Block Diagram	6	Operating Ranges	22
Connection Diagrams	7	DC Characteristics	23
Pin Configuration	8	TTL/NMOS Compatible	23
Logic Symbol	8	CMOS Compatible.....	23
Ordering Information	9	Test Conditions	24
Device Bus Operations	10	Figure 7. Test Setup.....	24
Table 1. Am29F040B Device Bus Operations	10	Table 6. Test Specifications	24
Requirements for Reading Array Data	10	Key to Switching Waveforms	24
Writing Commands/Command Sequences	10	AC Characteristics	25
Program and Erase Operation Status	11	Read Only Operations	25
Standby Mode	11	Figure 8. Read Operation Timings	25
Output Disable Mode.....	11	Erase and Program Operations	26
Table 2. Sector Addresses Table	11	Figure 9. Program Operation Timings	27
Autoselect Mode	12	Figure 10. Chip/Sector Erase Operation Timings	27
Table 3. Am29F040B Autoselect Codes (High Voltage Method)	12	Figure 11. Data# Polling Timings (During Embedded Algorithms)	28
Sector Protection/Unprotection.....	12	Figure 12. Toggle Bit Timings (During Embedded Algorithms).....	28
Hardware Data Protection	12	Figure 13. DQ2 vs. DQ6.....	29
Low V _{CC} Write Inhibit.....	12	AC Characteristics	30
Write Pulse “Glitch” Protection	13	Erase and Program Operations	30
Logical Inhibit	13	Alternate CE# Controlled Writes	30
Power-Up Write Inhibit	13	Figure 14. Alternate CE# Controlled Write Operation Timings	31
Command Definitions	13	Erase and Programming Performance	32
Reading Array Data	13	Latchup Characteristics	32
Reset Command.....	13	TSOP Pin Capacitance	32
Autoselect Command Sequence	13	PLCC and PDIP Pin Capacitance	33
Byte Program Command Sequence	14	Data Retention	33
Figure 1. Program Operation	14	Physical Dimensions	34
Chip Erase Command Sequence	14	PD 032—32-Pin Plastic DIP	34
Sector Erase Command Sequence	15	PL 032—32-Pin Plastic Leaded Chip Carrier	35
Erase Suspend/Erase Resume Commands.....	15	TS 032—32-Pin Standard Thin Small Package.....	36
Figure 2. Erase Operation	16	TSR032—32-Pin Reversed Thin Small Outline Package.....	37
Command Definitions	16	Revision Summary	38
Table 4. Am29F040B Command Definitions.....	16	Revision A (May 1997)	38
Write Operation Status	18	Revision B (January 1998)	38
DQ7: Data# Polling.....	18	Revision B+1 (January 1998)	38
Figure 3. Data# Polling Algorithm	18	Revision B+2 (April 1998).....	38
DQ6: Toggle Bit I	19	Revision C (January 1999)	38
DQ2: Toggle Bit II	19	Distinctive Characteristics.....	38
Reading Toggle Bits DQ6/DQ2	19	Revision C+1 (February 1999)	38
DQ5: Exceeded Timing Limits	20	Revision C+2 (May 17, 1999)	38
DQ3: Sector Erase Timer	20	Revision D (November 15, 1999)	38
Figure 4. Toggle Bit Algorithm.....	20	Revision E0 (November 29, 2000).....	38
Table 5. Write Operation Status.....	21	Revision E1 (September 21, 2004).....	38
Absolute Maximum Ratings	22		
Figure 5. Maximum Negative Overshoot Waveform	22		

Product Selector Guide

Family Part Number		Am29F040B				
Speed Option	$V_{CC} = 5.0\text{ V} \pm 5\%$	-55				
	$V_{CC} = 5.0\text{ V} \pm 10\%$		-70	-90	-120	-150
Max access time, ns (t_{ACC})		55	70	90	120	150
Max CE# access time, ns (t_{CE})		55	70	90	120	150
Max OE# access time, ns (t_{OE})		25	30	35	50	55

Note: See the "AC Characteristics" section for more information.

Block Diagram

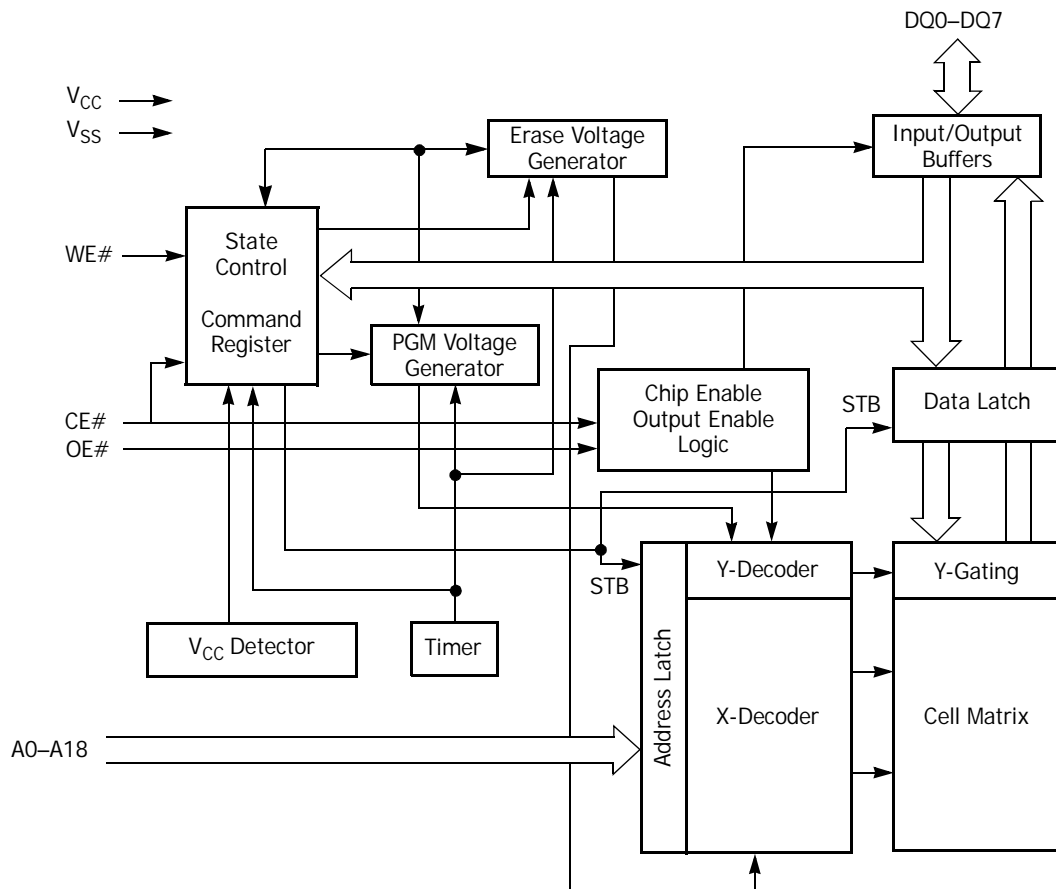

Connection Diagrams

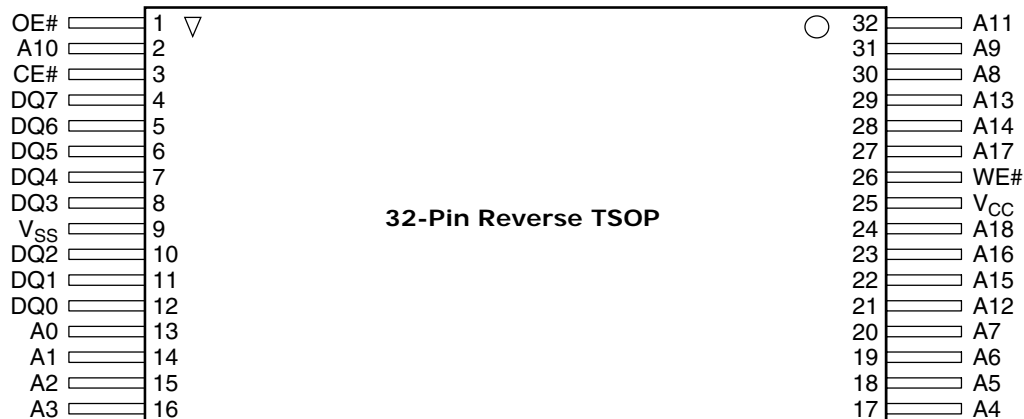
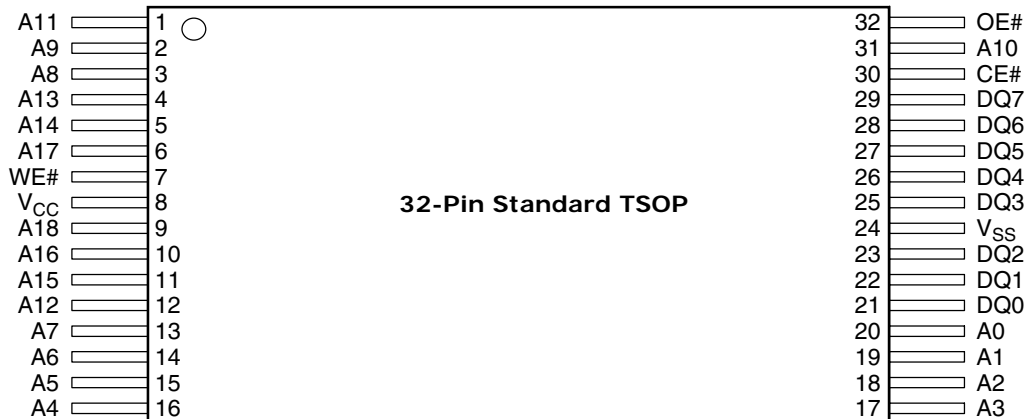
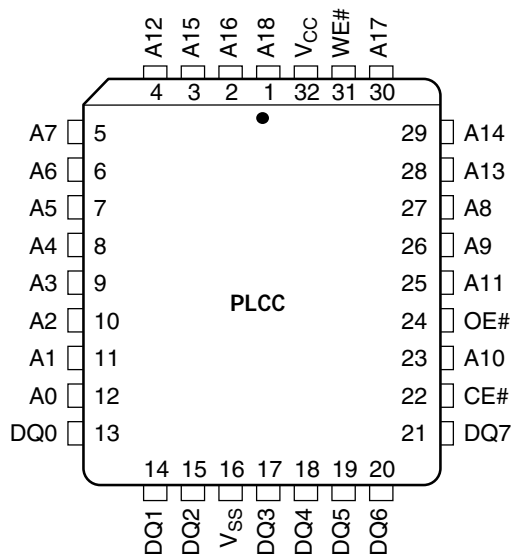
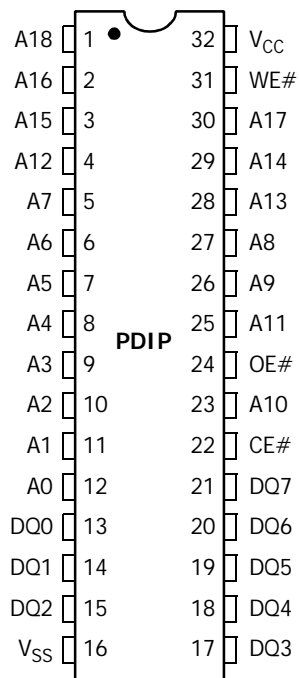

Pin Configuration

A0–A18	=	Address Inputs
DQ0–DQ7	=	Data Input/Output
CE#	=	Chip Enable
WE#	=	Write Enable
OE#	=	Output Enable
V _{SS}	=	Device Ground

V_{CC} = +5.0 V single power supply
(see Product Selector Guide for
device speed ratings and voltage
supply tolerances)

Logic Symbol

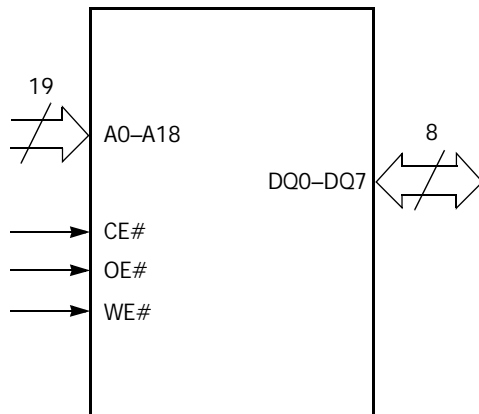

Ordering Information

Standard Products

AMD standard products are available in several packages and operating ranges. The order number (Valid Combination) is formed by a combination of the following:

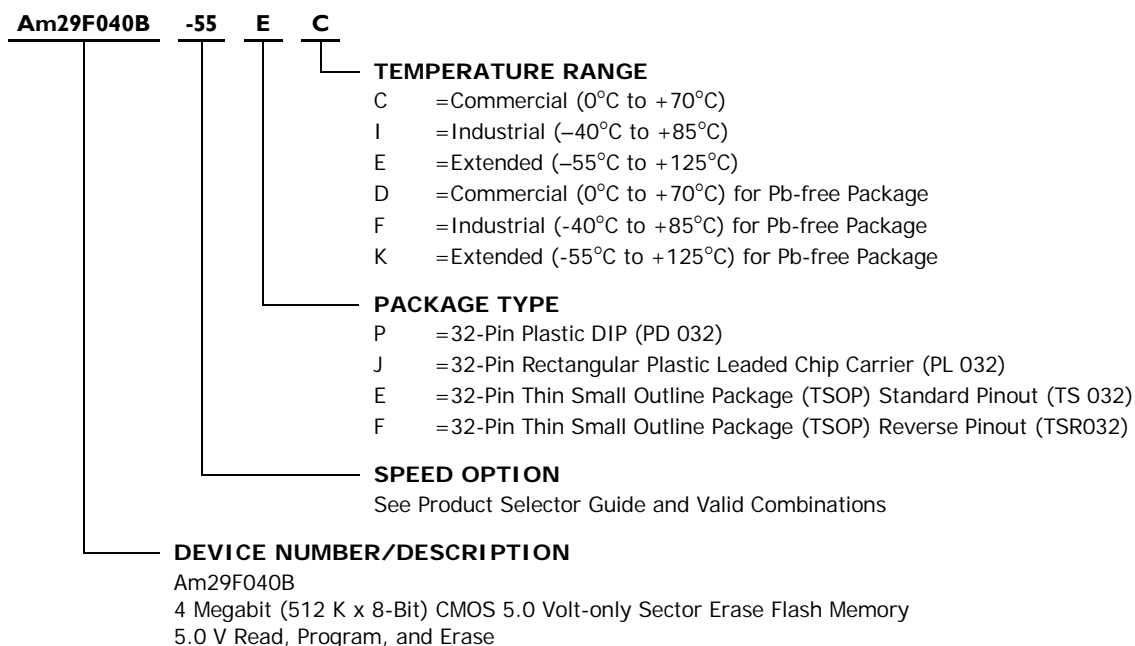

Valid Combinations		V _{CC} Voltage
AM29F040B-55	JC, JI, JE, ED EC, EI, EE, EF	5.0 V ± 5%
AM29F040B-70	FC, FI, FE, EK	
AM29F040B-90	PC, PI, PE, JC, JI, JE, EC, EI, EE, FC, FI, FE	5.0 V ± 10%
AM29F040B-120		
AM29F040B-150	ED, EF, EK	

Valid Combinations

Valid Combinations list configurations planned to be supported in volume for this device. Consult the local AMD sales office to confirm availability of specific valid combinations and to check on newly released combinations.

Device Bus Operations

This section describes the requirements and use of the device bus operations, which are initiated through the internal command register. The command register itself does not occupy any addressable memory location. The register is composed of latches that store the commands, along with the address and data information

needed to execute the command. The contents of the register serve as inputs to the internal state machine. The state machine outputs dictate the function of the device. The appropriate device bus operations table lists the inputs and control levels required, and the resulting output. The following subsections describe each of these operations in further detail.

Table I. Am29F040B Device Bus Operations

Operation	CE#	OE#	WE#	A0–A20	DQ0–DQ7
Read	L	L	H	A _{IN}	D _{OUT}
Write	L	H	L	A _{IN}	D _{IN}
CMOS Standby	V _{CC} ± 0.5 V	X	X	X	High-Z
TTL Standby	H	X	X	X	High-Z
Output Disable	L	H	H	X	High-Z

Legend:

L = Logic Low = V_{IL}, H = Logic High = V_{IH}, V_{ID} = 12.0 ± 0.5 V, X = Don't Care, D_{IN} = Data In, D_{OUT} = Data Out, A_{IN} = Address In

Note: See the "Sector Protection/Unprotection" section. for more information.

Requirements for Reading Array Data

To read array data from the outputs, the system must drive the CE# and OE# pins to V_{IL}. CE# is the power control and selects the device. OE# is the output control and gates array data to the output pins. WE# should remain at V_{IH}.

The internal state machine is set for reading array data upon device power-up, or after a hardware reset. This ensures that no spurious alteration of the memory content occurs during the power transition. No command is necessary in this mode to obtain array data. Standard microprocessor read cycles that assert valid addresses on the device address inputs produce valid data on the device data outputs. The device remains enabled for read access until the command register contents are altered.

See "Reading Array Data" for more information. Refer to the AC Read Operations table for timing specifications and to the Read Operations Timings diagram for the timing waveforms. I_{CC1} in the DC Characteristics table represents the active current specification for reading array data.

Writing Commands/ Command Sequences

To write a command or command sequence (which includes programming data to the device

and erasing sectors of memory), the system must drive WE# and CE# to V_{IL}, and OE# to V_{IH}.

An erase operation can erase one sector, multiple sectors, or the entire device. The Sector Address Tables indicate the address space that each sector occupies. A "sector address" consists of the address bits required to uniquely select a sector. See the "Command Definitions" section for details on erasing a sector or the entire chip, or suspending/resuming the erase operation.

After the system writes the autoselect command sequence, the device enters the autoselect mode. The system can then read autoselect codes from the internal register (which is separate from the memory array) on DQ7–DQ0. Standard read cycle timings apply in this mode. Refer to the "Autoselect Mode" and "Autoselect Command Sequence" sections for more information.

I_{CC2} in the DC Characteristics table represents the active current specification for the write mode. The "AC Characteristics" section contains timing specification tables and timing diagrams for write operations.

Program and Erase Operation Status

During an erase or program operation, the system may check the status of the operation by reading the status bits on DQ7–DQ0. Standard read cycle timings and I_{CC} read specifications apply. Refer to “[Write Operation Status](#)” for more information, and to each AC Characteristics section for timing diagrams.

Standby Mode

When the system is not reading or writing to the device, it can place the device in the standby mode. In this mode, current consumption is greatly reduced, and the outputs are placed in the high impedance state, independent of the OE# input.

The device enters the CMOS standby mode when the CE# pin is held at $V_{CC} \pm 0.5$ V. (Note that this is a more restricted voltage range than V_{IH} .) The device enters the TTL standby mode when CE# is held at V_{IH} . The device requires the standard access time (t_{CE}) before it is ready to read data.

If the device is deselected during erasure or programming, the device draws active current until the operation is completed.

I_{CC3} in the DC Characteristics tables represents the standby current specification.

Output Disable Mode

When the OE# input is at V_{IH} , output from the device is disabled. The output pins are placed in the high impedance state.

Table 2. Sector Addresses Table

Sector	A18	A17	A16	Address Range
SA0	0	0	0	00000h–0FFFFh
SA1	0	0	1	10000h–1FFFFh
SA2	0	1	0	20000h–2FFFFh
SA3	0	1	1	30000h–3FFFFh
SA4	1	0	0	40000h–4FFFFh
SA5	1	0	1	50000h–5FFFFh
SA6	1	1	0	60000h–6FFFFh
SA7	1	1	1	70000h–7FFFFh

Note: All sectors are 64 Kbytes in size.

Autoselect Mode

The autoselect mode provides manufacturer and device identification, and sector protection verification, through identifier codes output on DQ7–DQ0. This mode is primarily intended for programming equipment to automatically match a device to be programmed with its corresponding programming algorithm. However, the autoselect codes can also be accessed in-system through the command register.

When using programming equipment, the autoselect mode requires V_{ID} (11.5 V to 12.5 V) on address pin A9. Address pins A6, A1, and A0 must be as shown in Autoselect Codes (High Voltage Method) table. In addition, when verifying sector protection, the sector address must

appear on the appropriate highest order address bits. Refer to the corresponding Sector Address Tables. The Command Definitions table shows the remaining address bits that are don't care. When all necessary bits have been set as required, the programming equipment may then read the corresponding identifier code on DQ7–DQ0.

To access the autoselect codes in-system, the host system can issue the autoselect command via the command register, as shown in the Command Definitions table. This method does not require V_{ID} . See “[Command Definitions](#)” for details on using the autoselect mode.

Table 3. Am29F040B Autoselect Codes (High Voltage Method)

Description	A18–A16	A15–A10	A9	A8–A7	A6	A5–A2	A1	A0	Identifier Code on DQ7–DQ0
Manufacturer ID: AMD	X	X	V_{ID}	X	V_{IL}	X	V_{IL}	V_{IL}	01h
Device ID: Am29F040B	X	X	V_{ID}	X	V_{IL}	X	V_{IL}	V_{IH}	A4h
Sector Protection Verification	Sector Address	X	V_{ID}	X	V_{IL}	X	V_{IH}	V_{IL}	01h (protected)
									00h (unprotected)

Sector Protection/Unprotection

The hardware sector protection feature disables both program and erase operations in any sector. The hardware sector unprotection feature re-enables both program and erase operations in previously protected sectors.

Sector protection/unprotection must be implemented using programming equipment. The procedure requires a high voltage (V_{ID}) on address pin A9 and the control pins. Details on this method are provided in a supplement, publication number 19957. Contact an AMD representative to obtain a copy of the appropriate document.

The device is shipped with all sectors unprotected. AMD offers the option of programming and protecting sectors at its factory prior to shipping the device through AMD's Express-Flash™ Service. Contact an AMD representative for details.

It is possible to determine whether a sector is protected or unprotected. See “[Autoselect Mode](#)” for details.

Hardware Data Protection

The command sequence requirement of unlock cycles for programming or erasing provides data protection against inadvertent writes (refer to the Command Definitions table). In addition, the following hardware data protection measures prevent accidental erasure or programming, which might otherwise be caused by spurious system level signals during V_{CC} power-up and power-down transitions, or from system noise.

Low V_{CC} Write Inhibit

When V_{CC} is less than V_{LKO} , the device does not accept any write cycles. This protects data during V_{CC} power-up and power-down. The command register and all internal program/erase circuits are disabled, and the device resets. Subsequent writes are ignored until V_{CC} is greater than V_{LKO} . The system must provide the proper signals to the control pins to prevent unintentional writes when V_{CC} is greater than V_{LKO} .

Write Pulse “Glitch” Protection

Noise pulses of less than 5 ns (typical) on OE#, CE# or WE# do not initiate a write cycle.

Logical Inhibit

Write cycles are inhibited by holding any one of OE# = V_{IL}, CE# = V_{IH} or WE# = V_{IH}. To initiate

a write cycle, CE# and WE# must be a logical zero while OE# is a logical one.

Power-Up Write Inhibit

If WE# = CE# = V_{IL} and OE# = V_{IH} during power up, the device does not accept commands on the rising edge of WE#. The internal state machine is automatically reset to reading array data on power-up.

Command Definitions

Writing specific address and data commands or sequences into the command register initiates device operations. The Command Definitions table defines the valid register command sequences. Writing **incorrect address and data values** or writing them in the **improper sequence** resets the device to reading array data.

All addresses are latched on the falling edge of WE# or CE#, whichever happens later. All data is latched on the rising edge of WE# or CE#, whichever happens first. Refer to the appropriate timing diagrams in the [“AC Characteristics”](#) section.

Reading Array Data

The device is automatically set to reading array data after device power-up. No commands are required to retrieve data. The device is also ready to read array data after completing an Embedded Program or Embedded Erase algorithm.

After the device accepts an Erase Suspend command, the device enters the Erase Suspend mode. The system can read array data using the standard read timings, except that if it reads at an address within erase-suspended sectors, the device outputs status data. After completing a programming operation in the Erase Suspend mode, the system may once again read array data with the same exception. See [“Erase Suspend/Erase Resume Commands”](#) for more information on this mode.

The system *must* issue the reset command to re-enable the device for reading array data if DQ5 goes high, or while in the autoselect mode. See the [“Reset Command”](#) section, next.

See also [“Requirements for Reading Array Data”](#) in the [“Device Bus Operations”](#) section for more information. The Read Operations table provides the read parameters, and Read Operation Timing diagram shows the timing diagram.

Reset Command

Writing the reset command to the device resets the device to reading array data. Address bits are don't care for this command.

The reset command may be written between the sequence cycles in an erase command sequence before erasing begins. This resets the device to reading array data. Once erasure begins, however, the device ignores reset commands until the operation is complete.

The reset command may be written between the sequence cycles in a program command sequence before programming begins. This resets the device to reading array data (also applies to programming in Erase Suspend mode). Once programming begins, however, the device ignores reset commands until the operation is complete.

The reset command may be written between the sequence cycles in an autoselect command sequence. Once in the autoselect mode, the reset command *must* be written to return to reading array data (also applies to autoselect during Erase Suspend).

If DQ5 goes high during a program or erase operation, writing the reset command returns the device to reading array data (also applies during Erase Suspend).

Autoselect Command Sequence

The autoselect command sequence allows the host system to access the manufacturer and devices codes, and determine whether or not a sector is protected. The Command Definitions table shows the address and data requirements. This method is an alternative to that shown in the Autoselect Codes (High Voltage Method) table, which is intended for PROM programmers and requires V_{ID} on address bit A9.

The autoselect command sequence is initiated by writing two unlock cycles, followed by the autoselect command. The device then enters the

autoselect mode, and the system may read at any address any number of times, without initiating another command sequence.

A read cycle at address XX00h or retrieves the manufacturer code. A read cycle at address XX01h returns the device code. A read cycle containing a sector address (SA) and the address 02h in returns 01h if that sector is protected, or 00h if it is unprotected. Refer to the Sector Address tables for valid sector addresses.

The system must write the reset command to exit the autoselect mode and return to reading array data.

Byte Program Command Sequence

Programming is a four-bus-cycle operation. The program command sequence is initiated by writing two unlock write cycles, followed by the program set-up command. The program address and data are written next, which in turn initiate the Embedded Program algorithm. The system is *not* required to provide further controls or timings. The device automatically provides internally generated program pulses and verify the programmed cell margin. The Command Definitions table shows the address and data requirements for the byte program command sequence.

When the Embedded Program algorithm is complete, the device then returns to reading array data and addresses are no longer latched. The system can determine the status of the program operation by using DQ7 or DQ6. See "Write Operation Status" for information on these status bits.

Any commands written to the device during the Embedded Program Algorithm are ignored.

Programming is allowed in any sequence and across sector boundaries. **A bit cannot be programmed from a "0" back to a "1"**. Attempting to do so may halt the operation and set DQ5 to "1", or cause the Data# Polling algorithm to indicate the operation was successful. However, a succeeding read shows that the data is still "0". Only erase operations can convert a "0" to a "1".

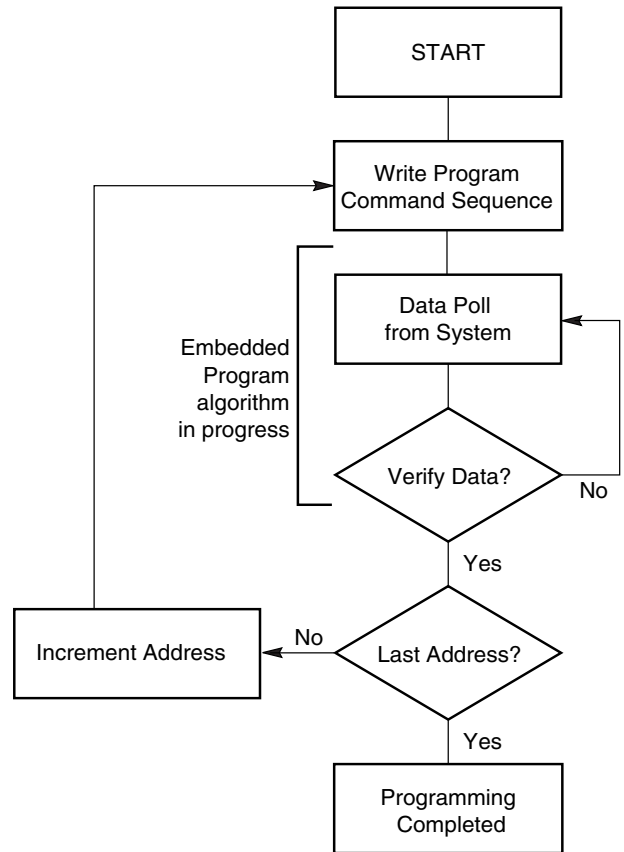

Note: See the appropriate Command Definitions table for program command sequence.

Figure I. Program Operation

Chip Erase Command Sequence

Chip erase is a six-bus-cycle operation. The chip erase command sequence is initiated by writing two unlock cycles, followed by a set-up command. Two additional unlock write cycles are then followed by the chip erase command, which in turn invokes the Embedded Erase algorithm. The device does *not* require the system to preprogram prior to erase. The Embedded Erase algorithm automatically preprograms and verifies the entire memory for an all zero data pattern prior to electrical erase. The system is not required to provide any controls or timings during these operations. The Command Definitions table shows the address and data requirements for the chip erase command sequence.

Any commands written to the chip during the Embedded Erase algorithm are ignored.

The system can determine the status of the erase operation by using DQ7, DQ6, or DQ2. See “[Write Operation Status](#)” for information on these status bits. When the Embedded Erase algorithm is complete, the device returns to reading array data and addresses are no longer latched.

Figure 2 illustrates the algorithm for the erase operation. See the Erase and Program Operations tables in “[AC Characteristics](#)” for parameters, and to the Chip/Sector Erase Operation Timings for timing waveforms.

Sector Erase Command Sequence

Sector erase is a six bus cycle operation. The sector erase command sequence is initiated by writing two unlock cycles, followed by a set-up command. Two additional unlock write cycles are then followed by the address of the sector to be erased, and the sector erase command. The Command Definitions table shows the address and data requirements for the sector erase command sequence.

The device does *not* require the system to pre-program the memory prior to erase. The Embedded Erase algorithm automatically programs and verifies the sector for an all zero data pattern prior to electrical erase. The system is not required to provide any controls or timings during these operations.

After the command sequence is written, a sector erase time-out of 50 μ s begins. During the time-out period, additional sector addresses and sector erase commands may be written. Loading the sector erase buffer may be done in any sequence, and the number of sectors may be from one sector to all sectors. The time between these additional cycles must be less than 50 μ s, otherwise the last address and command might not be accepted, and erasure may begin. It is recommended that processor interrupts be disabled during this time to ensure all commands are accepted. The interrupts can be re-enabled after the last Sector Erase command is written. If the time between additional sector erase commands can be assumed to be less than 50 μ s, the system need not monitor DQ3. **Any command other than Sector Erase or Erase Suspend during the time-out period resets the device to reading array data.** The system must rewrite the command sequence and any additional sector addresses and commands.

The system can monitor DQ3 to determine if the sector erase timer has timed out. (See the

“[DQ3: Sector Erase Timer](#)” section.) The time-out begins from the rising edge of the final WE# pulse in the command sequence.

Once the sector erase operation has begun, only the Erase Suspend command is valid. All other commands are ignored.

When the Embedded Erase algorithm is complete, the device returns to reading array data and addresses are no longer latched. The system can determine the status of the erase operation by using DQ7, DQ6, or DQ2. Refer to “[Write Operation Status](#)” for information on these status bits.

Figure 2 illustrates the algorithm for the erase operation. Refer to the Erase/Program Operations tables in the “[AC Characteristics](#)” section for parameters, and to the Sector Erase Operations Timing diagram for timing waveforms.

Erase Suspend/Erase Resume Commands

The Erase Suspend command allows the system to interrupt a sector erase operation and then read data from, or program data to, any sector not selected for erasure. This command is valid only during the sector erase operation, including the 50 μ s time-out period during the sector erase command sequence. The Erase Suspend command is ignored if written during the chip erase operation or Embedded Program algorithm. Writing the Erase Suspend command during the Sector Erase time-out immediately terminates the time-out period and suspends the erase operation. Addresses are “don’t-cares” when writing the Erase Suspend command.

When the Erase Suspend command is written during a sector erase operation, the device requires a maximum of 20 μ s to suspend the erase operation. However, when the Erase Suspend command is written during the sector erase time-out, the device immediately terminates the time-out period and suspends the erase operation.

After the erase operation has been suspended, the system can read array data from or program data to any sector not selected for erasure. (The device “erase suspends” all sectors selected for erasure.) Normal read and write timings and command definitions apply. Reading at any address within erase-suspended sectors produces status data on DQ7–DQ0. The system can use DQ7, or DQ6 and DQ2 together, to determine if a sector is actively erasing or is erase-sus-

pending. See [“Write Operation Status”](#) for information on these status bits.

After an erase-suspended program operation is complete, the system can once again read array data within non-suspended sectors. The system can determine the status of the program operation using the DQ7 or DQ6 status bits, just as in the standard program operation. See [“Write Operation Status”](#) for more information.

The system may also write the autoselect command sequence when the device is in the Erase Suspend mode. The device allows reading autoselect codes even at addresses within erasing sectors, since the codes are not stored in the memory array. When the device exits the autoselect mode, the device reverts to the Erase Suspend mode, and is ready for another valid operation. See [“Autoselect Command Sequence”](#) for more information.

The system must write the Erase Resume command (address bits are “don’t care”) to exit the erase suspend mode and continue the sector erase operation. Further writes of the Resume command are ignored. Another Erase Suspend command can be written after the device has resumed erasing.

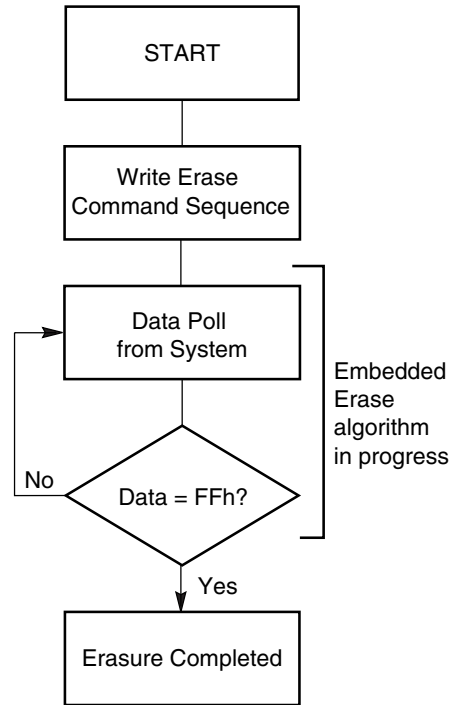

Notes:

1. See the appropriate *Command Definitions* table for erase command sequence.
2. See [“DQ3: Sector Erase Timer”](#) for more information.

Figure 2. Erase Operation

Command Definitions

Table 4. Am29F040B Command Definitions

Command Sequence (Note 1)		Cycles	Bus Cycles (Notes 2–4)											
			First		Second		Third		Fourth		Fifth		Sixth	
			Addr	Data	Addr	Data	Addr	Data	Addr	Data	Addr	Data	Addr	Data
Read (Note 5)		1	RA	RD										
Reset (Note 6)		1	XXX	F0										
Autoselect (Note 7)	Manufacturer ID	4	555	AA	2AA	55	555	90	X00	01				
	Device ID	4	555	AA	2AA	55	555	90	X01	A4				
	Sector Protect Verify (Note 8)	4	555	AA	2AA	55	555	90	SA X02	00 01				
Program		4	555	AA	2AA	55	555	A0	PA	PD				
Chip Erase		6	555	AA	2AA	55	555	80	555	AA	2AA	55	555	10
Sector Erase		6	555	AA	2AA	55	555	80	555	AA	2AA	55	SA	30
Erase Suspend (Note 9)		1	XXX	B0										
Erase Resume (Note 10)		1	XXX	30										

Legend:

X = Don't care

RA = Address of the memory location to be read.

RD = Data read from location RA during read operation.

PA = Address of the memory location to be programmed. Addresses latch on the falling edge of the WE# or CE# pulse, whichever happens later.

PD = Data to be programmed at location PA. Data latches on the rising edge of WE# or CE# pulse, whichever happens first.

SA = Address of the sector to be verified (in autoselect mode) or erased. Address bits A18–A16 select a unique sector.

Notes:

1. See Table 1 for description of bus operations.
2. All values are in hexadecimal.
3. Except when reading array or autoselect data, all bus cycles are write operations.
4. Address bits A18–A11 are don't cares for unlock and command cycles, unless SA or PA required.
5. No unlock or command cycles required when reading array data.
6. The Reset command is required to return to reading array data when device is in the autoselect mode, or if DQ5 goes high (while the device is providing status data).
7. The fourth cycle of the autoselect command sequence is a read cycle.
8. The data is 00h for an unprotected sector and 01h for a protected sector. See "Autoselect Command Sequence" for more information.
9. The system may read and program in non-erasing sectors, or enter the autoselect mode, when in the Erase Suspend mode. The Erase Suspend command is valid only during a sector erase operation.
10. The Erase Resume command is valid only during the Erase Suspend mode.

Write Operation Status

The device provides several bits to determine the status of a write operation: DQ2, DQ3, DQ5, DQ6, and DQ7. Table 5 and the following sub-sections describe the functions of these bits. DQ7 and DQ6 each offer a method for determining whether a program or erase operation is complete or in progress. These three bits are discussed first.

DQ7: Data# Polling

The Data# Polling bit, DQ7, indicates to the host system whether an Embedded Algorithm is in progress or completed, or whether the device is in Erase Suspend. Data# Polling is valid after the rising edge of the final WE# pulse in the program or erase command sequence.

During the Embedded Program algorithm, the device outputs on DQ7 the complement of the datum programmed to DQ7. This DQ7 status also applies to programming during Erase Suspend. When the Embedded Program algorithm is complete, the device outputs the datum programmed to DQ7. The system must provide the program address to read valid status information on DQ7. If a program address falls within a protected sector, Data# Polling on DQ7 is active for approximately 2 μ s, then the device returns to reading array data.

During the Embedded Erase algorithm, Data# Polling produces a "0" on DQ7. When the Embedded Erase algorithm is complete, or if the device enters the Erase Suspend mode, Data# Polling produces a "1" on DQ7. This is analogous to the complement/true datum output described for the Embedded Program algorithm: the erase function changes all the bits in a sector to "1"; prior to this, the device outputs the "complement," or "0." The system must provide an address within any of the sectors selected for erasure to read valid status information on DQ7.

After an erase command sequence is written, if all sectors selected for erasing are protected, Data# Polling on DQ7 is active for approximately 100 μ s, then the device returns to reading array data. If not all selected sectors are protected, the Embedded Erase algorithm erases the unprotected sectors, and ignores the selected sectors that are protected.

When the system detects DQ7 has changed from the complement to true data, it can read valid data at DQ7–DQ0 on the following read cycles. This is because DQ7 may change asynchronously with DQ0–DQ6 while Output Enable (OE#) is asserted low. The Data# Polling

Timings (During Embedded Algorithms) figure in the "AC Characteristics" section illustrates this.

Table 5 shows the outputs for Data# Polling on DQ7. Figure 3 shows the Data# Polling algorithm.

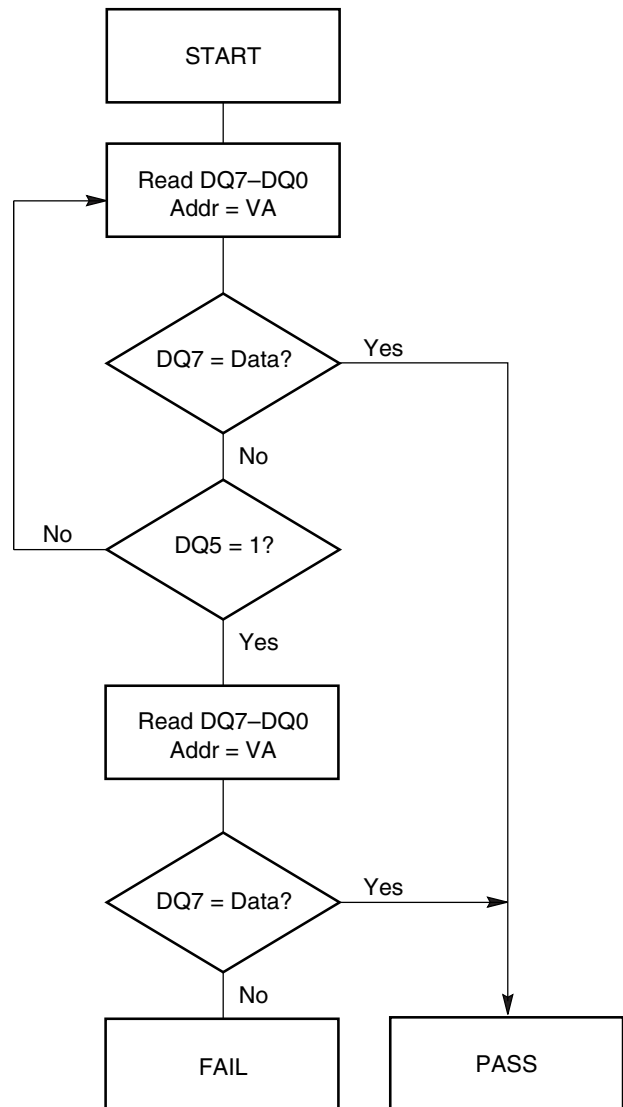

Notes:

1. VA = Valid address for programming. During a sector erase operation, a valid address is an address within any sector selected for erasure. During chip erase, a valid address is any non-protected sector address.
2. DQ7 should be rechecked even if DQ5 = "1" because DQ7 may change simultaneously with DQ5.

Figure 3. Data# Polling Algorithm

DQ6: Toggle Bit I

Toggle Bit I on DQ6 indicates whether an Embedded Program or Erase algorithm is in progress or complete, or whether the device has entered the Erase Suspend mode. Toggle Bit I may be read at any address, and is valid after the rising edge of the final WE# pulse in the command sequence (prior to the program or erase operation), and during the sector erase time-out.

During an Embedded Program or Erase algorithm operation, successive read cycles to any address cause DQ6 to toggle. (The system may use either OE# or CE# to control the read cycles.) When the operation is complete, DQ6 stops toggling.

After an erase command sequence is written, if all sectors selected for erasing are protected, DQ6 toggles for approximately 100 μ s, then returns to reading array data. If not all selected sectors are protected, the Embedded Erase algorithm erases the unprotected sectors, and ignores the selected sectors that are protected.

The system can use DQ6 and DQ2 together to determine whether a sector is actively erasing or is erase-suspended. When the device is actively erasing (that is, the Embedded Erase algorithm is in progress), DQ6 toggles. When the device enters the Erase Suspend mode, DQ6 stops toggling. However, the system must also use DQ2 to determine which sectors are erasing or erase-suspended. Alternatively, the system can use DQ7 (see the subsection on “DQ7: Data# Polling”).

If a program address falls within a protected sector, DQ6 toggles for approximately 2 μ s after the program command sequence is written, then returns to reading array data.

DQ6 also toggles during the erase-suspend-program mode, and stops toggling once the Embedded Program algorithm is complete.

The Write Operation Status table shows the outputs for Toggle Bit I on DQ6. Refer to Figure 4 for the toggle bit algorithm, and to the Toggle Bit Timings figure in the “AC Characteristics” section for the timing diagram. The DQ2 vs. DQ6 figure shows the differences between DQ2 and DQ6 in graphical form. See also the subsection on “DQ2: Toggle Bit II”.

DQ2: Toggle Bit II

The “Toggle Bit II” on DQ2, when used with DQ6, indicates whether a particular sector is actively erasing (that is, the Embedded Erase

algorithm is in progress), or whether that sector is erase-suspended. Toggle Bit II is valid after the rising edge of the final WE# pulse in the command sequence.

DQ2 toggles when the system reads at addresses within those sectors that have been selected for erasure. (The system may use either OE# or CE# to control the read cycles.) But DQ2 cannot distinguish whether the sector is actively erasing or is erase-suspended. DQ6, by comparison, indicates whether the device is actively erasing, or is in Erase Suspend, but cannot distinguish which sectors are selected for erasure. Thus, both status bits are required for sector and mode information. Refer to Table 5 to compare outputs for DQ2 and DQ6.

Figure 4 shows the toggle bit algorithm in flow-chart form, and the section “DQ2: Toggle Bit II” explains the algorithm. See also the “DQ6: Toggle Bit I” subsection. Refer to the Toggle Bit Timings figure for the toggle bit timing diagram. The DQ2 vs. DQ6 figure shows the differences between DQ2 and DQ6 in graphical form.

Reading Toggle Bits DQ6/DQ2

Refer to Figure 4 for the following discussion. Whenever the system initially begins reading toggle bit status, it must read DQ7–DQ0 at least twice in a row to determine whether a toggle bit is toggling. Typically, a system would note and store the value of the toggle bit after the first read. After the second read, the system would compare the new value of the toggle bit with the first. If the toggle bit is not toggling, the device has completed the program or erase operation. The system can read array data on DQ7–DQ0 on the following read cycle.

However, if after the initial two read cycles, the system determines that the toggle bit is still toggling, the system also should note whether the value of DQ5 is high (see the section on DQ5). If it is, the system should then determine again whether the toggle bit is toggling, since the toggle bit may have stopped toggling just as DQ5 went high. If the toggle bit is no longer toggling, the device has successfully completed the program or erase operation. If it is still toggling, the device did not complete the operation successfully, and the system must write the reset command to return to reading array data.

The remaining scenario is that the system initially determines that the toggle bit is toggling and DQ5 has not gone high. The system may continue to monitor the toggle bit and DQ5 through successive read cycles, determining the

status as described in the previous paragraph. Alternatively, it may choose to perform other system tasks. In this case, the system must start at the beginning of the algorithm when it returns to determine the status of the operation (top of Figure 4).

DQ5: Exceeded Timing Limits

DQ5 indicates whether the program or erase time has exceeded a specified internal pulse count limit. Under these conditions DQ5 produces a “1.” This is a failure condition that indicates the program or erase cycle was not successfully completed.

The DQ5 failure condition may appear if the system tries to program a “1” to a location that is previously programmed to “0.” **Only an erase operation can change a “0” back to a “1.”** Under this condition, the device halts the operation, and when the operation has exceeded the timing limits, DQ5 produces a “1.”

Under both these conditions, the system must issue the reset command to return the device to reading array data.

DQ3: Sector Erase Timer

After writing a sector erase command sequence, the system may read DQ3 to determine whether or not an erase operation has begun. (The sector erase timer does not apply to the chip erase command.) If additional sectors are selected for erasure, the entire time-out also applies after each additional sector erase command. When the time-out is complete, DQ3 switches from “0” to “1.” The system may ignore DQ3 if the system can guarantee that the time between additional sector erase commands is always less than 50 μs. See also the “Sector Erase Command Sequence” section.

After the sector erase command sequence is written, the system should read the status on DQ7 (Data# Polling) or DQ6 (Toggle Bit I) to ensure the device has accepted the command sequence, and then read DQ3. If DQ3 is “1”, the internally controlled erase cycle has begun; all further commands (other than Erase Suspend) are ignored until the erase operation is complete. If DQ3 is “0”, the device accepts additional sector erase commands. To ensure the command has been accepted, the system software should check the status of DQ3 prior to and following each subsequent sector erase

command. If DQ3 is high on the second status check, the last command might not have been accepted. Table 5 shows the outputs for DQ3.

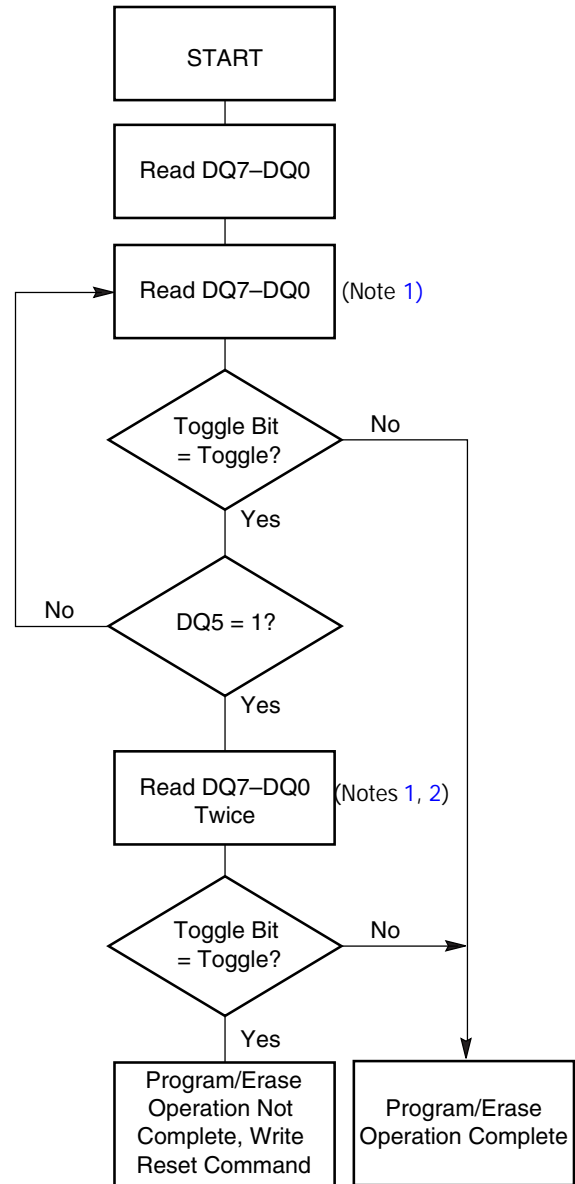

- Notes:**
1. Read toggle bit twice to determine whether or not it is toggling. See text.
 2. Recheck toggle bit because it may stop toggling as DQ5 changes to “1”. See text.

Figure 4. Toggle Bit Algorithm

Table 5. Write Operation Status

Operation		DQ7 (Note 1)	DQ6	DQ5 (Note 2)	DQ3	DQ2 (Note 1)
Standard Mode	Embedded Program Algorithm	DQ7#	Toggle	0	N/A	No toggle
	Embedded Erase Algorithm	0	Toggle	0	1	Toggle
Erase Suspend Mode	Reading within Erase Suspended Sector	1	No toggle	0	N/A	Toggle
	Reading within Non-Erase Suspended Sector	Data	Data	Data	Data	Data
	Erase-Suspend-Program	DQ7#	Toggle	0	N/A	N/A

Notes:

1. DQ7 and DQ2 require a valid address when reading status information. Refer to the appropriate subsection for further details.
2. DQ5 switches to '1' when an Embedded Program or Embedded Erase operation has exceeded the maximum timing limits. See "[DQ5: Exceeded Timing Limits](#)" for more information.

Absolute Maximum Ratings

Storage Temperature
Plastic Packages
–65°C to +125°C
Ambient Temperature
with Power Applied
–55°C to +125°C
Voltage with Respect
to Ground

V_{CC} (Note 1)	–2.0 V to 7.0 V
A9, OE# (Note 2)	–2.0 V to 12.5 V
All other pins (Note 1)	–2.0 V to 7.0 V
Output Short Circuit Current (Note 3)	200 mA

Notes:

1. Minimum DC voltage on input or I/O pins is –0.5 V. During voltage transitions, inputs may undershoot V_{SS} to –2.0 V for periods of up to 20 ns. See Figure 5. Maximum DC voltage on input and I/O pins is $V_{CC} + 0.5$ V. During voltage transitions, input and I/O pins may overshoot to $V_{CC} + 2.0$ V for periods up to 20 ns. See Figure 6.
2. Minimum DC input voltage on A9 pin is –0.5 V. During voltage transitions, A9 and OE# may undershoot V_{SS} to –2.0 V for periods of up to 20 ns. See Figure 5. Maximum DC input voltage on A9 and OE# is 12.5 V which may overshoot to 13.5 V for periods up to 20 ns.
3. No more than one output shorted to ground at a time. Duration of the short circuit should not be greater than one second.

Stresses above those listed under “Absolute Maximum Ratings” may cause permanent damage to the device. This is a stress rating only; functional operation of the

device at these or any other conditions above those indicated in the operational sections of this specification is not implied. Exposure of the device to absolute maximum rating conditions for extended periods may affect device reliability.

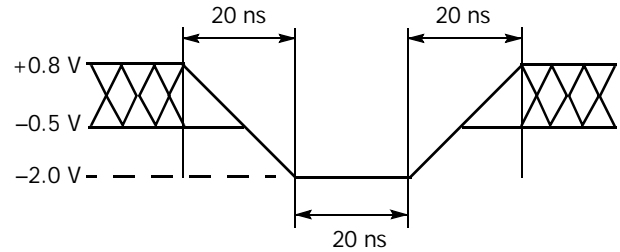

Figure 5. Maximum Negative Overshoot Waveform

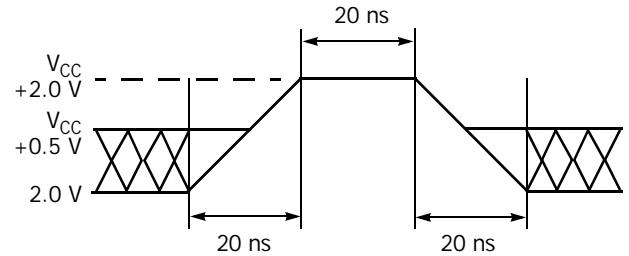

Figure 6. Maximum Positive Overshoot Waveform

Operating Ranges

Commercial (C) Devices

Ambient Temperature (T_A) 0°C to +70°C

Industrial (I) Devices

Ambient Temperature (T_A) –40°C to +85°C

Extended (E) Devices

Ambient Temperature (T_A) –55°C to +125°C

V_{CC} Supply Voltages

V_{CC} for ± 5% devices
+4.75 V to +5.25 V

V_{CC} for ± 10% devices
+4.5 V to +5.5 V

Operating ranges define those limits between which the functionality of the device is guaranteed.

DC Characteristics

TTL/NMOS Compatible

Parameter Symbol	Parameter Description	Test Description	Min	Typ	Max	Unit
I_{LI}	Input Load Current	$V_{IN} = V_{SS}$ to V_{CC} , $V_{CC} = V_{CC}$ Max			± 1.0	μA
I_{LIT}	A9 Input Load Current	$V_{CC} = V_{CC}$ Max, A9 = 12.5 V			50	μA
I_{LO}	Output Leakage Current	$V_{OUT} = V_{SS}$ to V_{CC} , $V_{CC} = V_{CC}$ Max			± 1.0	μA
I_{CC1}	V_{CC} Active Read Current (Notes 1, 2)	CE# = V_{IL} , OE# = V_{IH}		20	30	mA
I_{CC2}	V_{CC} Active Write (Program/Erase) Current (Notes 2, 3, 4)	CE# = V_{IL} , OE# = V_{IH}		30	40	mA
I_{CC3}	V_{CC} Standby Current (Note 2)	CE# = V_{IH}		0.4	1.0	mA
V_{IL}	Input Low Level		-0.5		0.8	V
V_{IH}	Input High Level		2.0		$V_{CC} + 0.5$	V
V_{ID}	Voltage for Autoselect and Sector Protect	$V_{CC} = 5.25$ V	10.5		12.5	V
V_{OL}	Output Low Voltage	$I_{OL} = 12$ mA, $V_{CC} = V_{CC}$ Min			0.45	V
V_{OH}	Output High Voltage	$I_{OH} = -2.5$ mA, $V_{CC} = V_{CC}$ Min	2.4			V
V_{LKO}	Low V_{CC} Lock-Out Voltage		3.2		4.2	V

CMOS Compatible

Parameter Symbol	Parameter Description	Test Description	Min	Typ	Max	Unit
I_{LI}	Input Load Current	$V_{IN} = V_{SS}$ to V_{CC} , $V_{CC} = V_{CC}$ Max			± 1.0	μA
I_{LIT}	A9 Input Load Current	$V_{CC} = V_{CC}$ Max, A9 = 12.5 V			50	μA
I_{LO}	Output Leakage Current	$V_{OUT} = V_{SS}$ to V_{CC} , $V_{CC} = V_{CC}$ Max			± 1.0	μA
I_{CC1}	V_{CC} Active Read Current (Notes 1, 2)	CE# = V_{IL} , OE# = V_{IH}		20	30	mA
I_{CC2}	V_{CC} Active Program/Erase Current (Notes 2, 3, 4)	CE# = V_{IL} , OE# = V_{IH}		30	40	mA
I_{CC3}	V_{CC} Standby Current (Notes 2, 5)	CE# = $V_{CC} \pm 0.5$ V		1	5	μA
V_{IL}	Input Low Level		-0.5		0.8	V
V_{IH}	Input High Level		$0.7 \times V_{CC}$		$V_{CC} + 0.3$	V
V_{ID}	Voltage for Autoselect and Sector Protect	$V_{CC} = 5.25$ V	10.5		12.5	V
V_{OL}	Output Low Voltage	$I_{OL} = 12.0$ mA, $V_{CC} = V_{CC}$ Min			0.45	V
V_{OH1}	Output High Voltage	$I_{OH} = -2.5$ mA, $V_{CC} = V_{CC}$ Min	$0.85 V_{CC}$			V
V_{OH2}		$I_{OH} = -100$ μA , $V_{CC} = V_{CC}$ Min	$V_{CC} - 0.4$			V
V_{LKO}	Low V_{CC} Lock-out Voltage		3.2		4.2	V

Notes for DC Characteristics (both tables):

- The I_{CC} current listed includes both the DC operating current and the frequency dependent component (at 6 MHz). The frequency component typically is less than 2 mA/MHz, with OE# at V_{IH} .
- Maximum I_{CC} specifications are tested with $V_{CC} = V_{CCmax}$.
- I_{CC} active while Embedded Algorithm (program or erase) is in progress.
- Not 100% tested.
- For CMOS mode only, $I_{CC3} = 20$ μA max at extended temperatures ($> +85^{\circ}C$).

Test Conditions

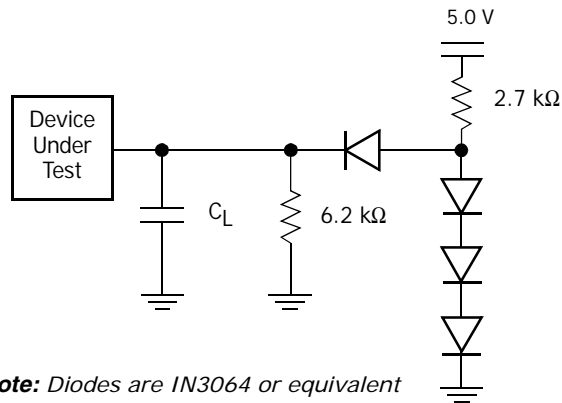

Note: Diodes are IN3064 or equivalent

Figure 7. Test Setup

Table 6. Test Specifications

Test Condition	-55	All others	Unit
Output Load	1 TTL gate		
Output Load Capacitance, C_L (including jig capacitance)	30	100	pF
Input Rise and Fall Times	5	20	ns
Input Pulse Levels	0.0–3.0	0.45–2.4	V
Input timing measurement reference levels	1.5	0.8, 2.0	V
Output timing measurement reference levels	1.5	0.8, 2.0	V

Key to Switching Waveforms

WAVEFORM	INPUTS	OUTPUTS
	Steady	
	Changing from H to L	
	Changing from L to H	
	Don't Care, Any Change Permitted	Changing, State Unknown
	Does Not Apply	Center Line is High Impedance State (High Z)

AC Characteristics

Read Only Operations

Parameter Symbols		Description	Test Setup		Speed Options (Note 1)					Unit
JEDEC	Std				-55	-70	-90	-120	-150	
t_{AVAV}	t_{RC}	Read Cycle Time (Note 3)		Min	55	70	90	120	150	ns
t_{AVOQV}	t_{ACC}	Address to Output Delay	$CE\# = V_{IL}$, $OE\# = V_{IL}$	Max	55	70	90	120	150	ns
t_{ELQV}	t_{CE}	Chip Enable to Output Delay	$OE\# = V_{IL}$	Max	55	70	90	120	150	ns
t_{GLQV}	t_{OE}	Output Enable to Output Delay		Max	30	30	35	50	55	ns
	t_{OEH}	Output Enable Hold Time (Note 3)	Read	Min	0	0	0	0	0	ns
			Toggle and Data# Polling	Min	10	10	10	10	10	ns
t_{EHOZ}	t_{DF}	Chip Enable to Output High Z (Notes 2, 3)		Max	18	20	20	30	35	ns
t_{GHOZ}	t_{DF}	Output Enable to Output High Z (Notes 2, 3)			18	20	20	30	35	ns
t_{AXQX}	t_{OH}	Output Hold Time from Addresses, CE# or OE#, Whichever Occurs First		Min	0	0	0	0	0	ns

Notes:

1. See Figure 7 and Table 6 for test conditions.
2. Output driver disable time.
3. Not 100% tested.

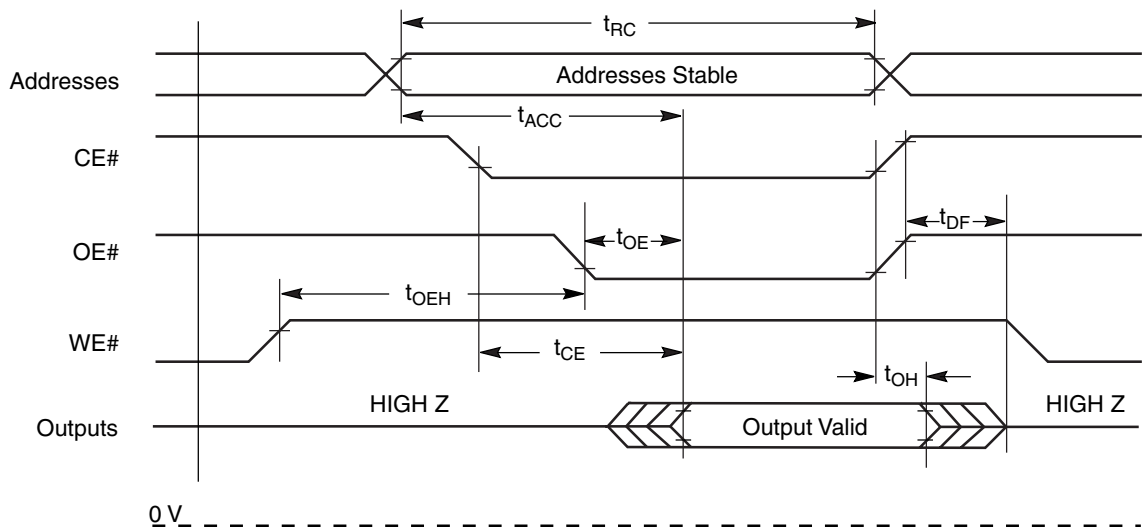

Figure 8. Read Operation Timings

AC Characteristics

Erase and Program Operations

Parameter Symbols		Description		Speed Options					Unit
JEDEC	Std			-55	-70	-90	-120	-150	
t_{AVAV}	t_{WC}	Write Cycle Time (Note 1)	Min	55	70	90	120	150	ns
t_{AVWL}	t_{AS}	Address Setup Time	Min	0					ns
t_{WLAX}	t_{AH}	Address Hold Time	Min	40	45	45	50	50	ns
t_{DVWH}	t_{DS}	Data Setup Time	Min	25	30	45	50	50	ns
t_{WHDX}	t_{DH}	Data Hold Time	Min	0					ns
	t_{OES}	Output Enable Setup Time	Min	0					ns
t_{GHWL}	t_{GHWL}	Read Recover Time Before Write (OE# high to WE# low)	Min	0					ns
t_{ELWL}	t_{CS}	CE# Setup Time	Min	0					ns
t_{WHEH}	t_{CH}	CE# Hold Time	Min	0					ns
t_{WLWH}	t_{WP}	Write Pulse Width	Min	30	35	45	50	50	ns
t_{WHWL}	t_{WPH}	Write Pulse Width High	Min	20					ns
t_{WHWH1}	t_{WHWH1}	Byte Programming Operation (Note 2)	Typ	7					μ s
t_{WHWH2}	t_{WHWH2}	Sector Erase Operation (Note 2)	Typ	1					sec
	t_{VCS}	V_{CC} Set Up Time (Note 1))	Min	50					μ s

Notes:

1. Not 100% tested.
2. See the "Erase and Programming Performance" section for more information.

AC Characteristics

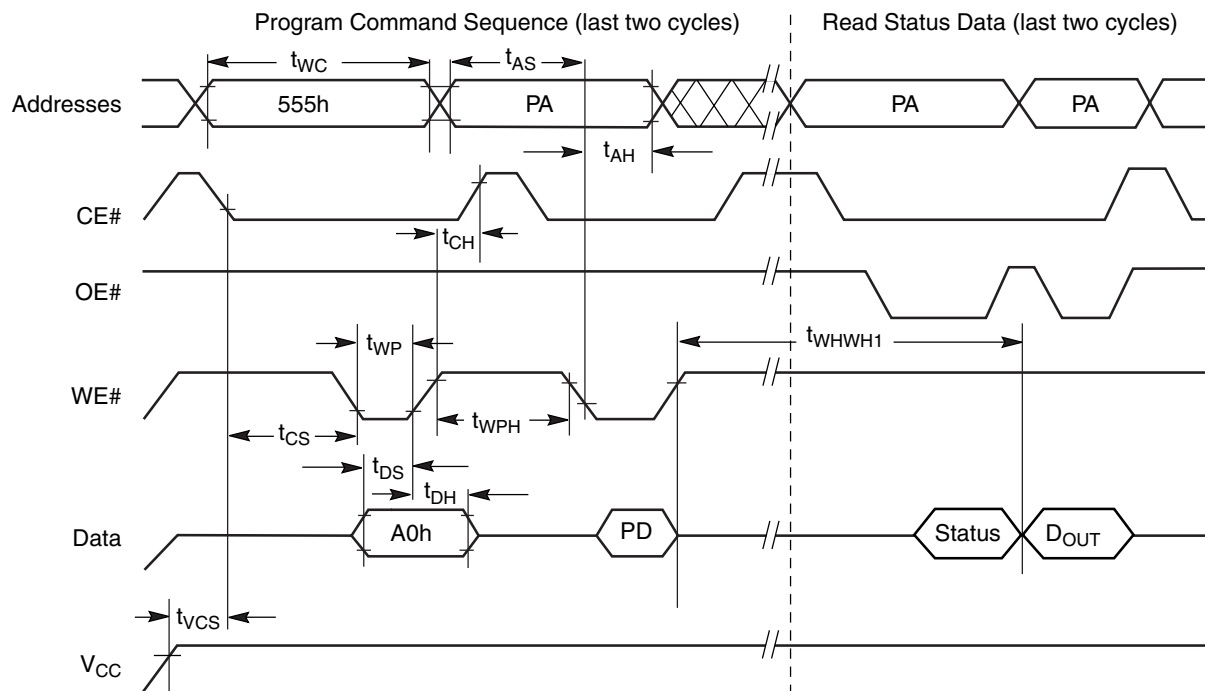

Note: PA = program address, PD = program data, D_{OUT} is the true data at the program address.

Figure 9. Program Operation Timings

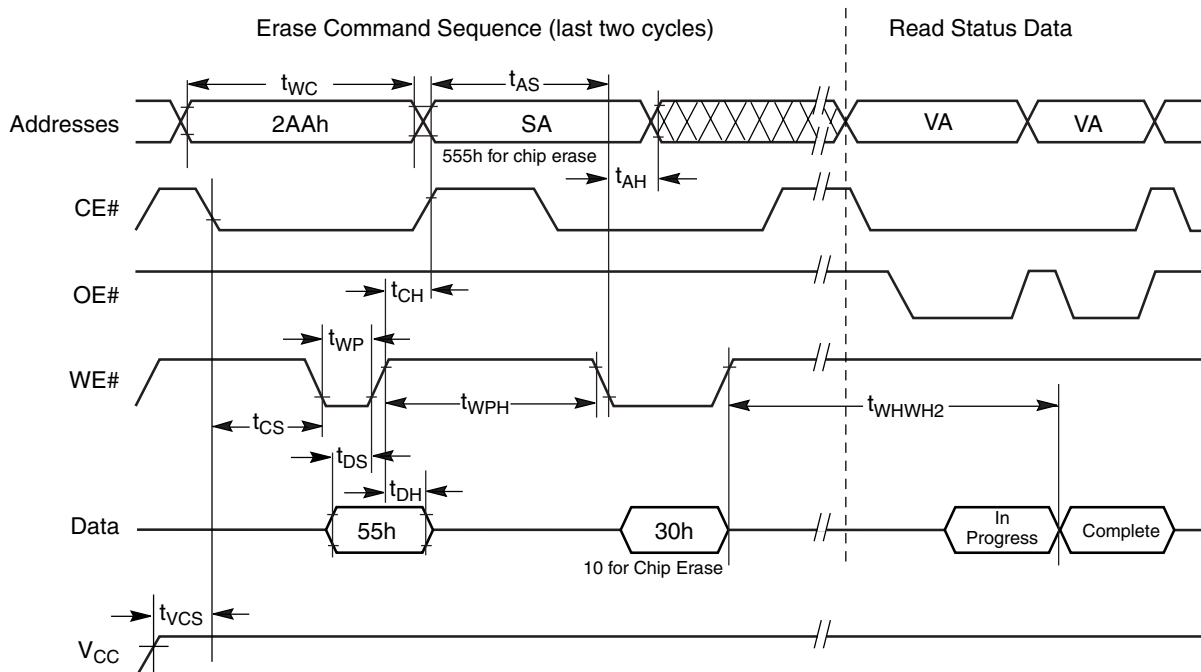

Note:
SA = Sector Address. VA = Valid Address for reading status data.

Figure 10. Chip/Sector Erase Operation Timings

AC Characteristics

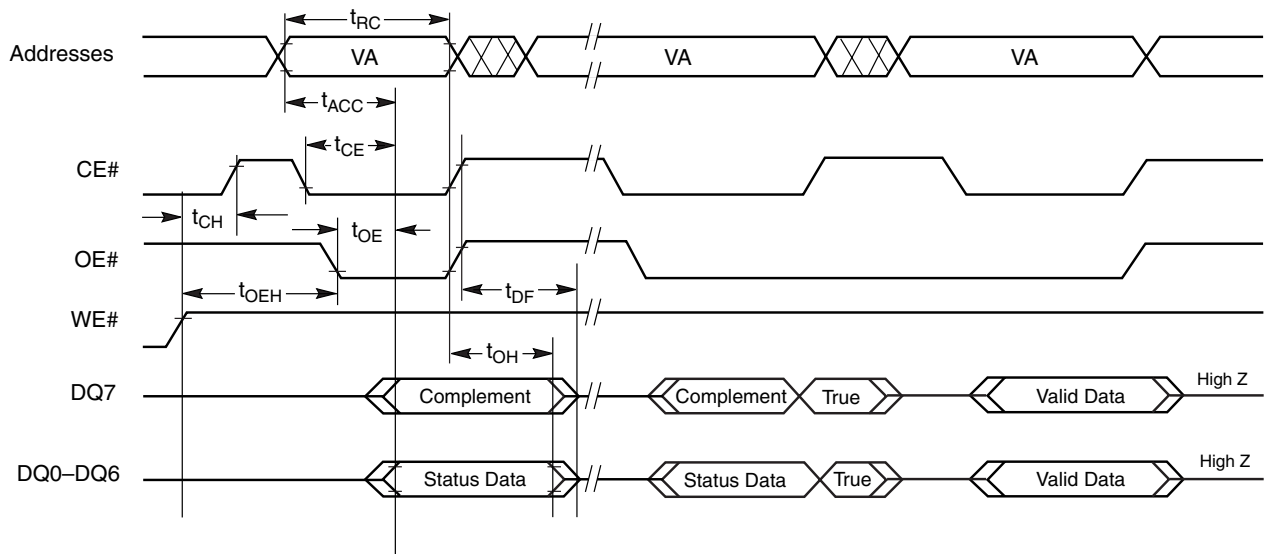

Note: VA = Valid address. Illustration shows first status cycle after command sequence, last status read cycle, and array data read cycle .

Figure II. Data# Polling Timings (During Embedded Algorithms)

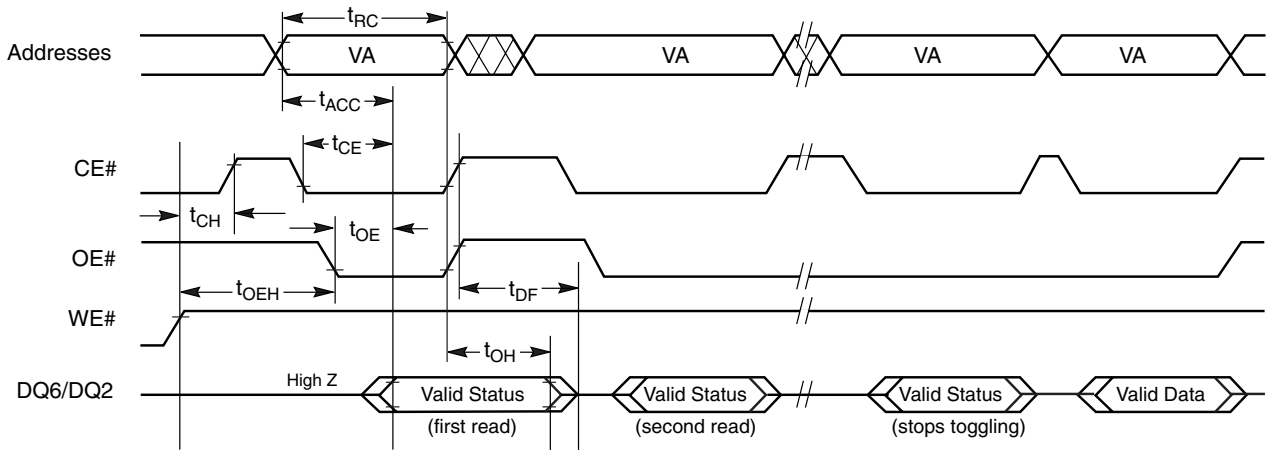

Note: VA = Valid address; not required for DQ6. Illustration shows first two status cycle after command sequence, last status read cycle, and array data read cycle.

Figure I2. Toggle Bit Timings (During Embedded Algorithms)

AC Characteristics

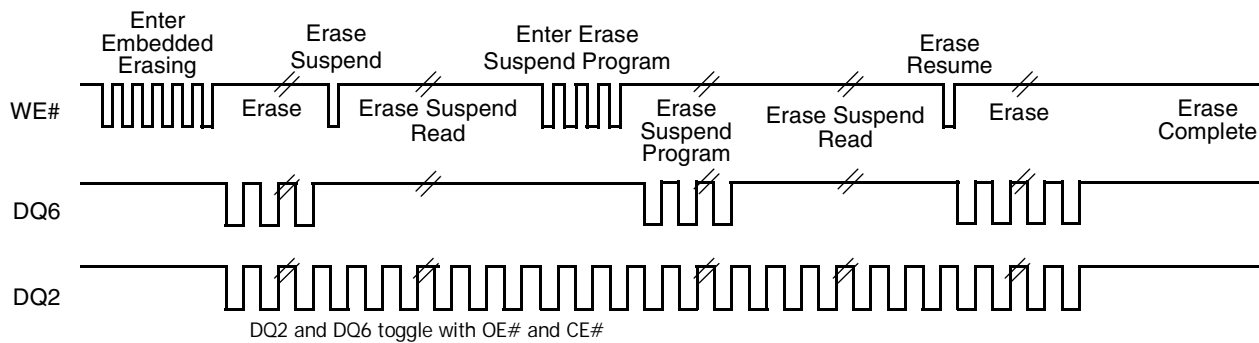

Note: Both DQ6 and DQ2 toggle with OE# or CE#. See the text on DQ6 and DQ2 in the section [“Write Operation Status”](#) for more information.

Figure I3. DQ2 vs. DQ6

AC Characteristics

Erase and Program Operations

Alternate CE#
Controlled
Writes

Parameter Symbols		Description		Speed Options					Unit
JEDEC	Std			-55	-70	-90	-120	-150	
t_{AVAV}	t_{WC}	Write Cycle Time (Note 1))	Min	55	70	90	120	150	ns
t_{AVEL}	t_{AS}	Address Setup Time	Min	0					ns
t_{ELAX}	t_{AH}	Address Hold Time	Min	40	45	45	50	50	ns
t_{DVEH}	t_{DS}	Data Setup Time	Min	25	30	45	50	50	ns
t_{EHDX}	t_{DH}	Data Hold Time	Min	0					ns
t_{GHLEL}	t_{GHLEL}	Read Recover Time Before Write	Min	0					ns
t_{WLEL}	t_{WS}	CE# Setup Time	Min	0					ns
t_{EHWH}	t_{WH}	CE# Hold Time	Min	0					ns
t_{ELEH}	t_{CP}	Write Pulse Width	Min	30	35	45	50	50	ns
t_{EHEL}	t_{CPH}	Write Pulse Width High	Min	20	20	20	20	20	ns
t_{WHWH1}	t_{WHWH1}	Byte Programming Operation (Note 2))	Typ	7					μ s
t_{WHWH2}	t_{WHWH2}	Sector Erase Operation (Note 2))	Typ	1					sec

Notes:

1. Not 100% tested.
2. See the ["Erase and Programming Performance"](#) section for more information.

AC Characteristics

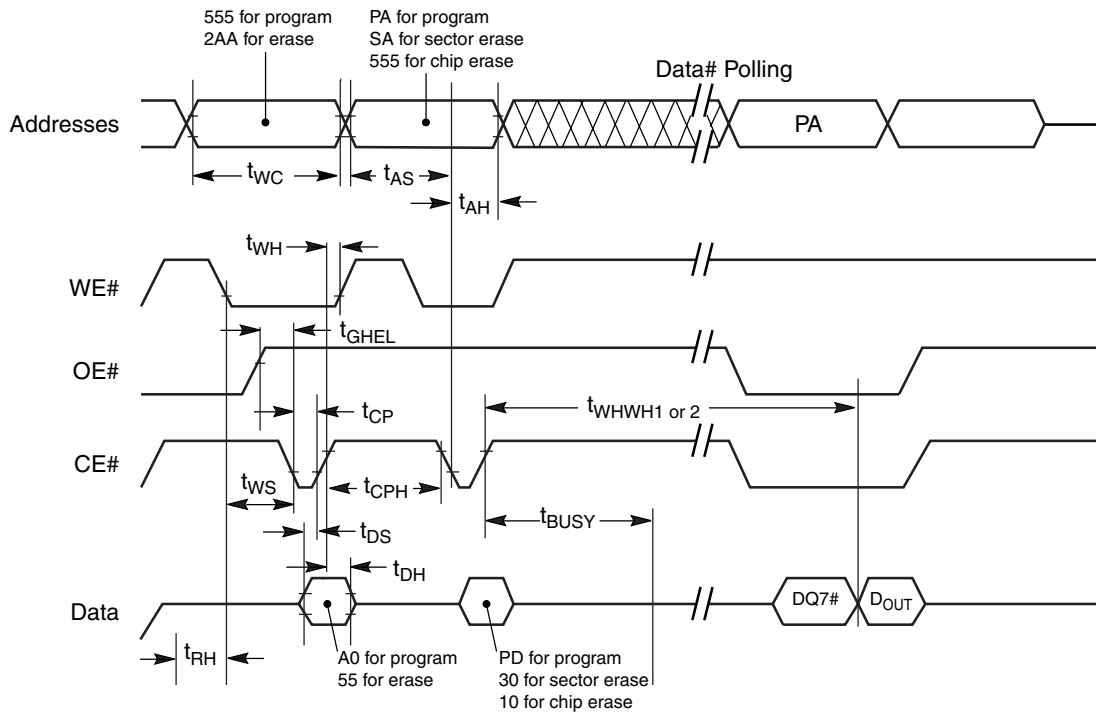

Notes:

1. PA = Program Address, PD = Program Data, SA = Sector Address, DQ7# = Complement of Data Input, D_{OUT} = Array Data.
2. Figure indicates the last two bus cycles of the command sequence.

Figure 14. Alternate CE# Controlled Write Operation Timings

Erase and Programming Performance

Parameter	Typ (Note 1)	Max (Note 2)	Unit	Comments
Sector Erase Time	1	8	sec	Excludes 00h programming prior to erasure (Note 4)
Chip Erase Time	8	64	sec	
Byte Programming Time	7	300	µs	Excludes system-level overhead (Note 5)
Chip Programming Time (Note 3)	3.6	10.8	sec	

Notes:

1. Typical program and erase times assume the following conditions: 25°C, 5.0 V V_{CC} , 1,000,000 cycles. Additionally, programming typicals assume checkerboard pattern.
2. Under worst case conditions of 90°C, $V_{CC} = 4.5$ V (4.75 V for -55), 1,000,000 cycles.
3. The typical chip programming time is considerably less than the maximum chip programming time listed, since most bytes program faster than the maximum byte program time listed. If the maximum byte program time given is exceeded, only then does the device set $DQ5 = 1$. See the section on $DQ5$ for further information.
4. In the pre-programming step of the Embedded Erase algorithm, all bytes are programmed to 00h before erasure.
5. System-level overhead is the time required to execute the four-bus-cycle command sequence for programming. See Table 4 for further information on command definitions.
6. The device has a guaranteed minimum erase and program cycle endurance of 1,000,000 cycles.

Latchup Characteristics

	Min	Max
Input Voltage with respect to V_{SS} on all I/O pins	-1.0 V	$V_{CC} + 1.0$ V
V_{CC} Current	-100 mA	+100 mA

Includes all pins except V_{CC} . Test conditions: $V_{CC} = 5.0$ V, one pin at a time.

TSOP Pin Capacitance

Parameter Symbol	Parameter Description	Test Setup	Typ	Max	Unit
C_{IN}	Input Capacitance	$V_{IN} = 0$	6	7.5	pF
C_{OUT}	Output Capacitance	$V_{OUT} = 0$	8.5	12	pF
C_{IN2}	Control Pin Capacitance	$V_{IN} = 0$	7.5	9	pF

Notes:

1. Sampled, not 100% tested.
2. Test conditions $T_A = 25^\circ\text{C}$, $f = 1.0$ MHz.

PLCC and PDIP Pin Capacitance

Parameter Symbol	Parameter Description	Test Setup	Typ	Max	Unit
C_{IN}	Input Capacitance	$V_{IN} = 0$	4	6	pF
C_{OUT}	Output Capacitance	$V_{OUT} = 0$	8	12	pF
C_{IN2}	Control Pin Capacitance	$V_{PP} = 0$	8	12	pF

Notes:

1. Sampled, not 100% tested.
2. Test conditions $T_A = 25^\circ\text{C}$, $f = 1.0\text{ MHz}$.

Data Retention

Parameter	Test Conditions	Min	Unit
Minimum Pattern Data Retention Time	150°C	10	Years
	125°C	20	Years

Physical Dimensions

PD 032—32-Pin Plastic DIP

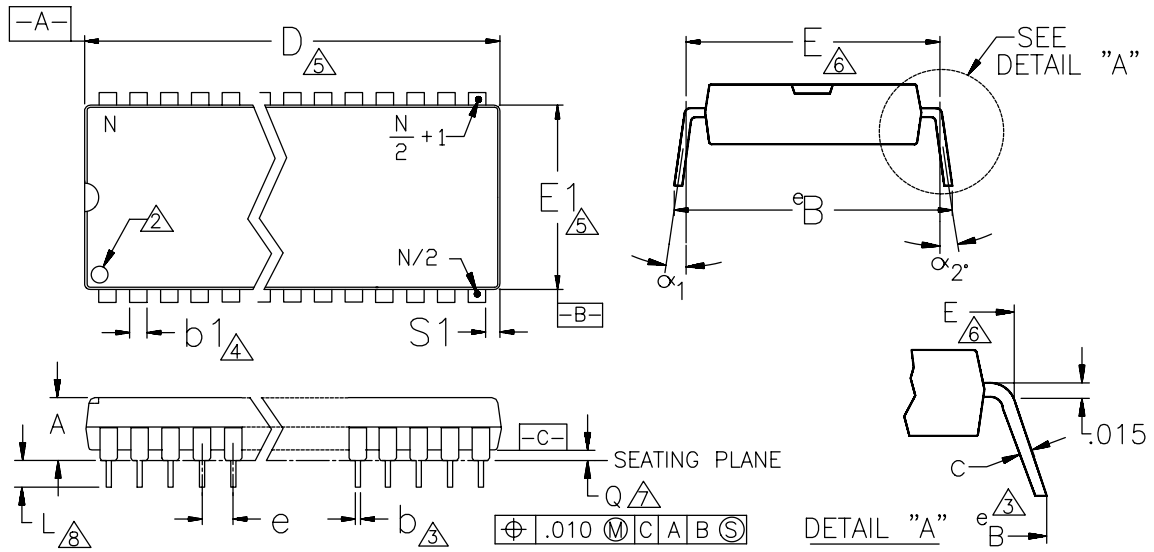

Dwg rev AD; 10/99

PACKAGE	PD 032	
JEDEC	MO-015(G)AP	
SYMBOL	MIN	MAX
A	.140	.225
b	.016	.022
b1	.045	.065
c	.009	.015
D	1.640	1.670
E1	.530	.580
E	.600	.625
e	.090	.110
L	.120	.150
Q	.015	.060
S1	.005	-
e _B	.630	.700
N	32	
$\langle \alpha_1 - \alpha_2 \rangle$	0°	10°
$\langle \alpha_1, \alpha_2 \rangle$	0°	15°

NOTES:

1. ALL DIMENSIONS ARE GIVEN IN INCHES.
2. A NOTCH, TAB, OR PIN ONE IDENTIFICATION MARK SHALL BE LOCATED ADJACENT TO PIN ONE.
3. ALL LEADS IN DIMENSIONS b AND c INCREASE BY 3 MILS MAX. WHEN TIN PLATE /SOLDER DIP LEAD FINISH IS APPLIED.
4. THE MINIMUM LIMIT FOR DIMENSION b1 MAY BE .030 INCH IN FOUR CORNER LEADS FOR PD 016, PD3 024, PDW 024, PD3 028, PDW 028.
5. D AND E1 DIMENSIONS DO NOT INCLUDE MOLD FLASH OR PROTRUSION.
6. E IS MEASURED FROM THE OUTSIDE OF LEADS AND 15 MILS BELOW PLANE OF PKG EXIT DEFINED BY LEAD TOP.
7. Q IS MEASURED FROM THE SEATING PLANE TO THE BASE PLANE.
8. L IS MEASURED FROM SEATING PLANE OR .040 INCH LEAD SHOULDER WIDTH/GAUGE HOLE SOCKET TO THE LEAD TIP.
9. WHEN STANDOFF HAS RADII, THE SEATING PLANE LOCATION IS DEFINED WHERE LEAD WIDTH EQUALS .040".
10. 'N' IS THE LEAD COUNT.

Physical Dimensions (continued)

PL 032—32-Pin Plastic Leaded Chip Carrier

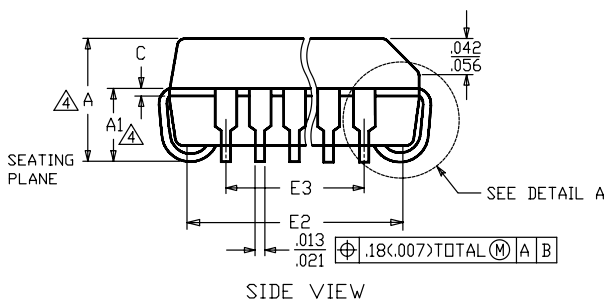
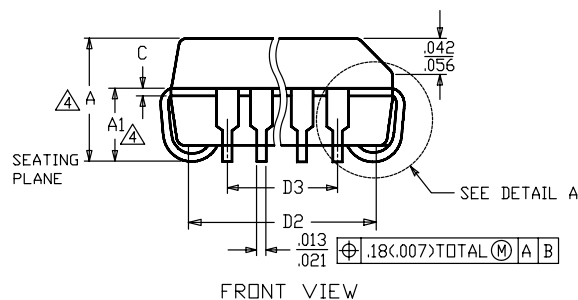
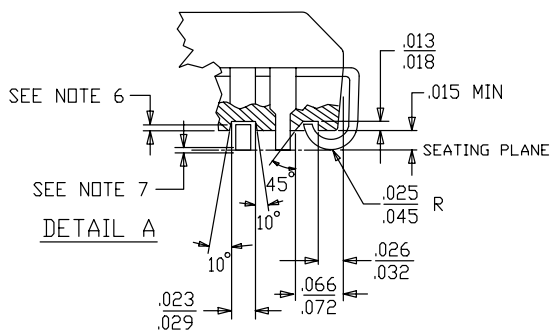
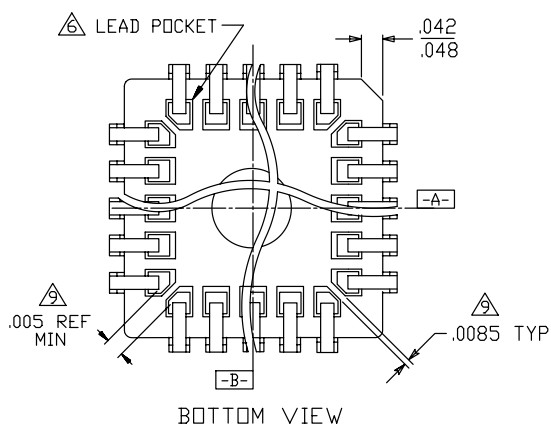
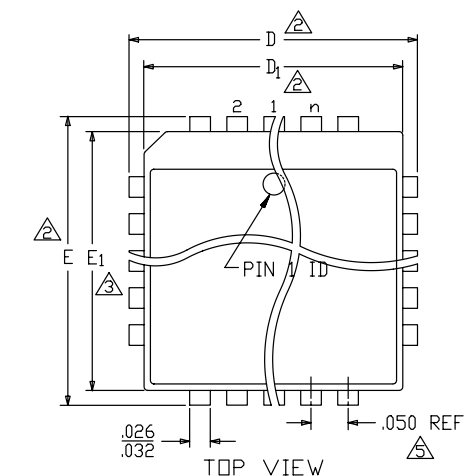

PACKAGE	PL32	
JEDEC	MO-052(A)AE	
SYMBOL	MIN	MAX
A	.125	.140
A1	.080	.095
D	.485	.495
D1	.447	.453
D2	.390	.430
D3	.300	REF
E	.585	.595
E1	.547	.553
E2	.490	.530
E3	.400	REF
C	.009	.015

NOTES:

Dwg rev AH; 10/99

- ALL DIMENSIONS ARE IN INCHES.
- DIMENSIONS "D" AND "E" ARE MEASURED FROM OUTERMOST POINT.
- DIMENSIONS D1 AND E1 DO NOT INCLUDE CORNER MOLD FLASH. ALLOWABLE CORNER MOLD FLASH IS .010"
- DIMENSIONS "A", "A1", "D2" AND "E2" ARE MEASURED AT THE POINTS OF CONTACT TO BASE PLANE
- LEAD SPACING AS MEASURED FROM CENTERLINE TO CENTERLINE SHALL BE WITHIN $\pm .005$ ".
- J-LEAD TIPS SHOULD BE LOCATED INSIDE THE "POCKET".
- LEAD COPLANARITY SHALL BE WITHIN .004" AS MEASURED FROM SEATING PLANE. COPLANARITY IS MEASURED PER AMD 06-500.
- LEAD TWEEZE SHALL BE WITHIN .0045" ON EACH SIDE AS MEASURED FROM A VERTICAL FLAT PLANE. TWEEZE IS MEASURED PER AMD 06-500.
- LEAD POCKET MAY BE RECTANGULAR (AS SHOWN) OR OVAL. IF CORNER LEAD POCKETS ARE CONNECTED THEN 5 MILS MINIMUM CORNER LEAD SPACING IS REQUIRED.

Physical Dimensions (continued)

TS 032—32-Pin Standard Thin Small Package

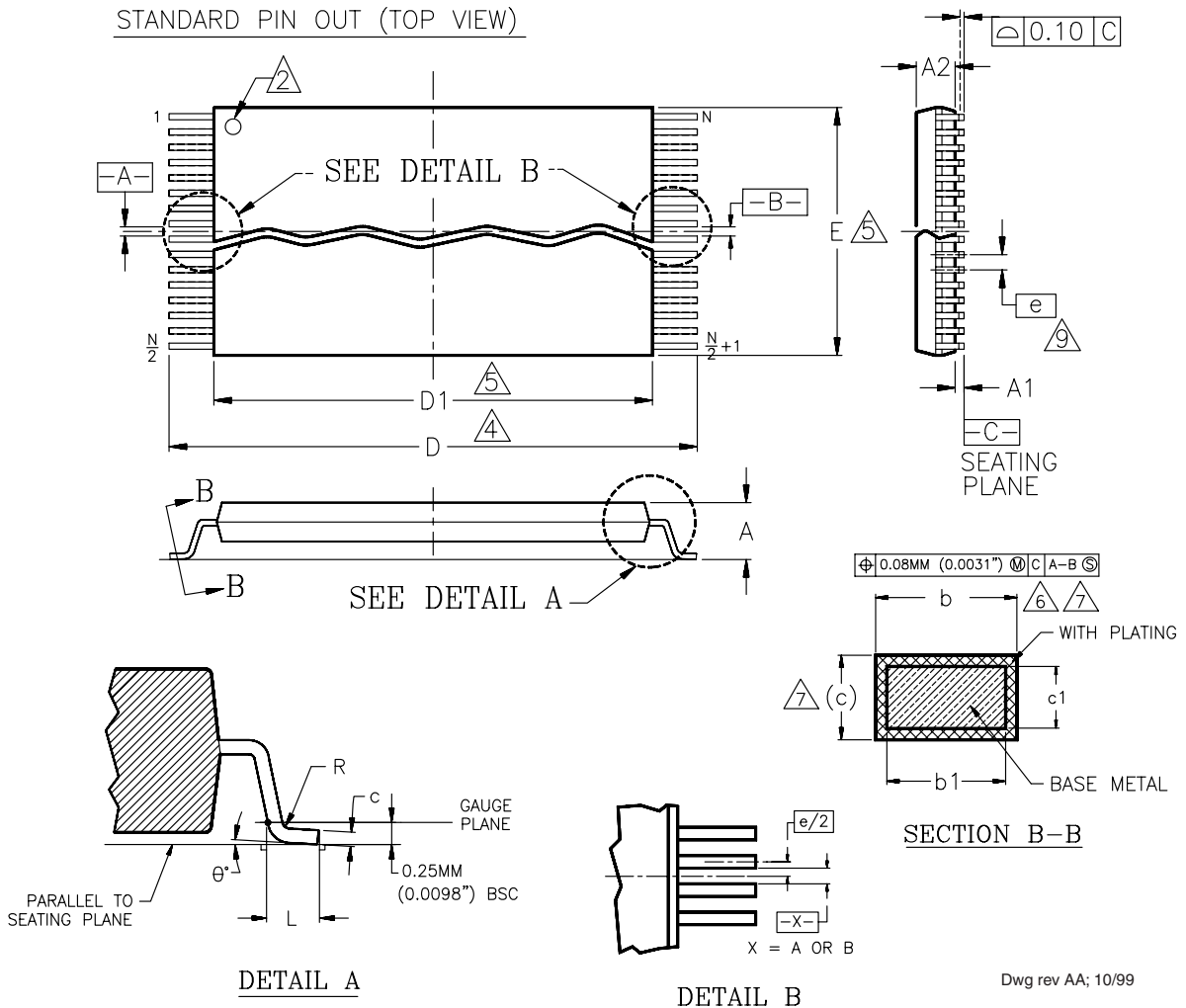

Package	TS 32		
Jedec	MO-142 (B) BD		
Symbol	MIN	NOM	MAX
A	—	—	1.20
A1	0.05	—	0.15
A2	0.95	1.00	1.05
b1	0.17	0.20	0.23
b	0.17	0.22	0.27
c1	0.10	—	0.16
c	0.10	—	0.21
D	19.80	20.00	20.20
D1	18.30	18.40	18.50
E	7.90	8.00	8.10
e	0.50 BASIC		
L	0.50	0.60	0.70
θ	0°	3°	5°
R	0.08	—	0.20
N	32		

NOTES:

1. CONTROLLING DIMENSIONS ARE IN MILLIMETERS (mm). (DIMENSIONING AND TOLERANCING CONFORMS TO ANSI Y14.5M-1982)
2. PIN 1 IDENTIFIER FOR STANDARD PIN OUT (DIE UP).
3. PIN 1 IDENTIFIER FOR REVERSE PIN OUT (DIE DOWN): INK OR LASER MARK.
4. TO BE DETERMINED AT THE SEATING PLANE [C], THE SEATING PLANE IS DEFINED AS THE PLANE OF CONTACT THAT IS MADE WHEN THE PACKAGE LEADS ARE ALLOWED TO REST FREELY ON A FLAT HORIZONTAL SURFACE.
5. DIMENSIONS D1 AND E DO NOT INCLUDE MOLD PROTRUSION. ALLOWABLE MOLD PROTRUSION IS 0.15mm (0.0059") PER SIDE.
6. DIMENSION b DOES NOT INCLUDE DAMBAR PROTRUSION. ALLOWABLE DAMBAR PROTRUSION SHALL BE 0.08mm (0.0031") TOTAL IN EXCESS OF b DIMENSION AT MAX. MATERIAL CONDITION. MINIMUM SPACE BETWEEN PROTRUSION AND AN ADJACENT LEAD TO BE 0.07mm (0.0028").
7. THESE DIMENSIONS APPLY TO THE FLAT SECTION OF THE LEAD BETWEEN 0.10mm (0.0039") AND 0.25mm (0.0098") FROM THE LEAD TIP.
8. LEAD COPLANARITY SHALL BE WITHIN 0.10mm (0.004") AS MEASURED FROM THE SEATING PLANE.
9. DIMENSION "e" IS MEASURED AT THE CENTERLINE OF THE LEADS.

Physical Dimensions (continued)

TSR032—32-Pin Reversed Thin Small Outline Package

REVERSE PIN OUT (TOP VIEW)

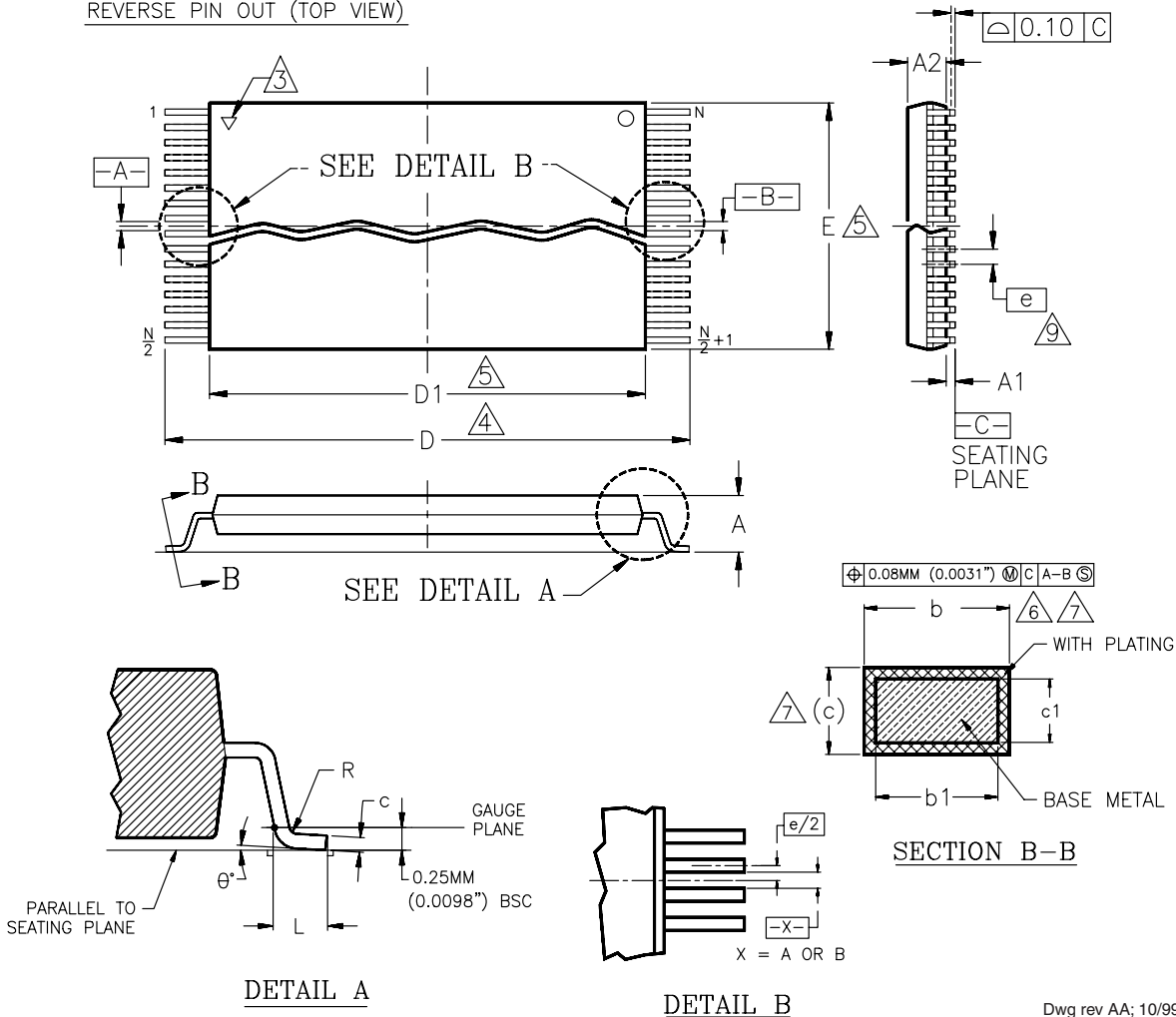

Dwg rev AA; 10/99

Package	TSR32		
Jedec	MO-142 (B) BD		
Symbol	MIN	NOM	MAX
A	—	—	1.20
A1	0.05	—	0.15
A2	0.95	1.00	1.05
b1	0.17	0.20	0.23
b	0.17	0.22	0.27
c1	0.10	—	0.16
c	0.10	—	0.21
D	19.80	20.00	20.20
D1	18.30	18.40	18.50
E	7.90	8.00	8.10
e	0.50 BASIC		
L	0.50	0.60	0.70
θ	0°	3°	5°
R	0.08	—	0.20
N	32		

NOTES:

1. CONTROLLING DIMENSIONS ARE IN MILLIMETERS (mm).
(DIMENSIONING AND TOLERANCING CONFORMS TO ANSI Y14.5M-1982)
2. PIN 1 IDENTIFIER FOR STANDARD PIN OUT (DIE UP).
3. PIN 1 IDENTIFIER FOR REVERSE PIN OUT (DIE DOWN); INK OR LASER MARK.
4. TO BE DETERMINED AT THE SEATING PLANE [C]. THE SEATING PLANE IS DEFINED AS THE PLANE OF CONTACT THAT IS MADE WHEN THE PACKAGE LEADS ARE ALLOWED TO REST FREELY ON A FLAT HORIZONTAL SURFACE.
5. DIMENSIONS D1 AND E DO NOT INCLUDE MOLD PROTRUSION. ALLOWABLE MOLD PROTRUSION IS 0.15mm (0.0059") PER SIDE.
6. DIMENSION b DOES NOT INCLUDE DAMBAR PROTRUSION. ALLOWABLE DAMBAR PROTRUSION SHALL BE 0.08mm (0.0031") TOTAL IN EXCESS OF b DIMENSION AT MAX. MATERIAL CONDITION. MINIMUM SPACE BETWEEN PROTRUSION AND AN ADJACENT LEAD TO BE 0.07mm (0.0028").
7. THESE DIMENSIONS APPLY TO THE FLAT SECTION OF THE LEAD BETWEEN 0.10mm (0.0039") AND 0.25mm (0.0098") FROM THE LEAD TIP.
8. LEAD COPLANARITY SHALL BE WITHIN 0.10mm (0.004") AS MEASURED FROM THE SEATING PLANE.
9. DIMENSION "e" IS MEASURED AT THE CENTERLINE OF THE LEADS.

Revision Summary

Revision A (May 1997)

Initial release.

Revision B (January 1998)

Global

Formatted for consistency with other 5.0 volt-only data sheets.

Revision B+I (January 1998)

AC Characteristics, Erase and Program Operations

Added Note references to t_{WHWH1} . Corrected the parameter symbol for V_{CC} Set-up Time to t_{VCS} ; the specification is 50 μs minimum. Deleted the last row in table.

Revision B+2 (April 1998)

Distinctive Characteristics

Changed minimum 100K write/erase cycles guaranteed to 1,000,000.

Ordering Information

Added extended temperature availability to the -55 and -70 speed options.

AC Characteristics

Erase and Program Operations; Erase and Program Operations Alternate CE# Controlled Writes: Corrected the notes reference for t_{WHWH1} and t_{WHWH2} . These parameters are 100% tested. Corrected the note reference for t_{VCS} . This parameter is not 100% tested.

Erase and Programming Performance

Changed minimum 100K program and erase cycles guaranteed to 1,000,000.

Revision C (January 1999)

Global

Updated for CS39S process technology.

Distinctive Characteristics

Added 20-year data retention bullet.

DC Characteristics—TTL/NMOS Compatible

V_{OH} : Changed the parameter description to "Output High Voltage" from Output High Level".

DC Characteristics—TTL/NMOS Compatible and CMOS Compatible

I_{CC1} , I_{CC2} , I_{CC3} : Added Note 2 "Maximum I_{CC} specifications are tested with $V_{\text{CC}} = V_{\text{CCmax}}$ ".

I_{CC3} : Deleted $V_{\text{CC}} = V_{\text{CCMax}}$.

Revision C+I (February 1999)

Command Definitions

Command Definitions table: Deleted "XX" from the fourth cycle data column of the Sector Protect Verify command.

Revision C+2 (May 17, 1999)

Test Specifications Table

Corrected the input and output measurement entries in the "All others" column.

Revision D (November 15, 1999)

AC Characteristics—Figure 9. Program Operations Timing and Figure 10. Chip/Sector Erase Operations

Deleted t_{GHWL} and changed OE# waveform to start at high.

Physical Dimensions

Replaced figures with more detailed illustrations.

Revision E0 (November 29, 2000)

Added table of contents.

Ordering Information

Deleted burn-in option.

Revision E1 (October 4, 2004)

Added PB-Free option to Standard Ordering Matrix.

Updated Valid Combinations

Colophon

The products described in this document are designed, developed and manufactured as contemplated for general use, including without limitation, ordinary industrial use, general office use, personal use, and household use, but are not designed, developed and manufactured as contemplated (1) for any use that includes fatal risks or dangers that, unless extremely high safety is secured, could have a serious effect to the public, and could lead directly to death, personal injury, severe physical damage or other loss (i.e., nuclear reaction control in nuclear facility, aircraft flight control, air traffic control, mass transport control, medical life support system, missile launch control in weapon system), or (2) for any use where chance of failure is intolerable (i.e., submersible repeater and artificial satellite). Please note that Spansion LLC will not be liable to you and/or any third party for any claims or damages arising in connection with above-mentioned uses of the products. Any semiconductor devices have an inherent chance of failure. You must protect against injury, damage or loss from such failures by incorporating safety design measures into your facility and equipment such as redundancy, fire protection, and prevention of over-current levels and other abnormal operating conditions. If any products described in this document represent goods or technologies subject to certain restrictions on export under the Foreign Exchange and Foreign Trade Law of Japan, the US Export Administration Regulations or the applicable laws of any other country, the prior authorization by the respective government entity will be required for export of those products.

Trademarks and Notice

The contents of this document are subject to change without notice. This document may contain information on a Spansion LLC product under development by Spansion LLC. Spansion LLC reserves the right to change or discontinue work on any product without notice. The information in this document is provided as is without warranty or guarantee of any kind as to its accuracy, completeness, operability, fitness for particular purpose, merchantability, non-infringement of third-party rights, or any other warranty, express, implied, or statutory. Spansion LLC assumes no liability for any damages of any kind arising out of the use of the information in this document.

Copyright ©2004 Spansion LLC. All rights reserved. Spansion, the Spansion logo, and MirrorBit are trademarks of Spansion LLC. Other company and product names used in this publication are for identification purposes only and may be trademarks of their respective companies

Product Selector Guide	4	Figure 5. Maximum Negative Overshoot Waveform	20
Block Diagram	4	Figure 6. Maximum Positive Overshoot Waveform	20
Connection Diagrams	5	Operating Ranges	20
Pin Configuration	6	DC Characteristics	21
Logic Symbol	6	TTL/NMOS Compatible	21
Ordering Information	7	CMOS Compatible	21
Device Bus Operations	8	Test Conditions	22
Table 1. Am29F040B Device Bus Operations	8	Figure 7. Test Setup	22
Requirements for Reading Array Data	8	Table 6. Test Specifications	22
Writing Commands/Command Sequences	8	Key to Switching Waveforms	22
Program and Erase Operation Status	9	AC Characteristics	23
Standby Mode	9	Read Only Operations	23
Output Disable Mode	9	Figure 8. Read Operation Timings	23
Table 2. Sector Addresses Table	9	Erase and Program Operations	24
Autoselect Mode	10	Figure 9. Program Operation Timings	25
Table 3. Am29F040B Autoselect Codes (High Voltage Method)	10	Figure 10. Chip/Sector Erase Operation Timings	25
Sector Protection/Unprotection	10	Figure 11. Data# Polling Timings (During Embedded Algorithms)	26
Hardware Data Protection	10	Figure 12. Toggle Bit Timings (During Embedded Algorithms)	26
Low V _{CC} Write Inhibit	10	Figure 13. DQ2 vs. DQ6	27
Write Pulse "Glitch" Protection	11	AC Characteristics	28
Logical Inhibit	11	Erase and Program Operations	28
Power-Up Write Inhibit	11	Alternate CE# Controlled Writes	28
Command Definitions	11	Figure 14. Alternate CE# Controlled Write Operation Timings	29
Reading Array Data	11	Erase and Programming Performance	30
Reset Command	11	Latchup Characteristics	30
Autoselect Command Sequence	11	TSOP Pin Capacitance	30
Byte Program Command Sequence	12	PLCC and PDIP Pin Capacitance	31
Figure 1. Program Operation	12	Data Retention	31
Chip Erase Command Sequence	12	Physical Dimensions	32
Sector Erase Command Sequence	13	PD 032—32-Pin Plastic DIP	32
Erase Suspend/Erase Resume Commands	13	PL 032—32-Pin Plastic Leaded Chip Carrier	33
Figure 2. Erase Operation	14	TS 032—32-Pin Standard Thin Small Package	34
Command Definitions	14	TSR032—32-Pin Reversed Thin Small Outline Package	35
Table 4. Am29F040B Command Definitions	14	Revision Summary	36
Write Operation Status	16	Revision A (May 1997)	36
DQ7: Data# Polling	16	Revision B (January 1998)	36
Figure 3. Data# Polling Algorithm	16	Revision B+1 (January 1998)	36
DQ6: Toggle Bit I	17	Revision B+2 (April 1998)	36
DQ2: Toggle Bit II	17	Revision C (January 1999)	36
Reading Toggle Bits DQ6/DQ2	17	Distinctive Characteristics	36
DQ5: Exceeded Timing Limits	18	Revision C+1 (February 1999)	36
DQ3: Sector Erase Timer	18	Revision C+2 (May 17, 1999)	36
Figure 4. Toggle Bit Algorithm	18	Revision D (November 15, 1999)	36
Table 5. Write Operation Status	19	Revision E0 (November 29, 2000)	36
Absolute Maximum Ratings	20	Revision E1 (September 21, 2004)	36