

# Am8216 • Am8226

## Four-Bit Parallel Bidirectional Bus Driver

### Distinctive Characteristics

- Data bus buffer driver for 8080 type CPU's
- Low input load current – 0.25mA maximum
- High output drive capability for driving system data bus – 50mA at 0.5V
- Am8216 has non-inverting outputs
- Output high voltage compatible with direct interface to MOS
- Three-state outputs
- Advanced Schottky processing
- Available in military and commercial temperature range
- Am8226 has inverting outputs

### FUNCTIONAL DESCRIPTION

The Am8216 and Am8226 are four-bit, bi-directional bus drivers for use in bus oriented applications. The non-inverting Am8216, and inverting Am8226 drivers are provided for flexibility in system design.

Each buffered line of the four bit driver consists of two separate buffers that are three-state to achieve direct bus interface and bi-directional capability. On one side of the driver the output of one buffer and the input of another are tied together (DB), this side is used to interface to the system side components such as memories, I/O, etc., because its interface is TTL compatible and it has high drive (50mA). On the other side of the driver the inputs and outputs are separated to provide maximum flexibility. Of course, they can be tied together so that the driver can be used to buffer a true bi-directional bus.

The DO outputs on this side of the driver have a special high voltage output drive capability so that direct interface to the 8080 type CPUs is achieved with an adequate amount of noise immunity.

The  $\overline{CS}$  input is a device enable. When it is "high" the output drivers are all forced to their high-impedance state. When it is a "LOW" the device is enabled and the direction of the data flow is determined by the  $\overline{DIEN}$  input.

The  $\overline{DIEN}$  input controls the direction of data flow which is accomplished by forcing one of the pair of buffers into its high impedance state and allowing the other to transmit its data. A simple two gate circuit is used for this function.

### LOGIC DIAGRAMS

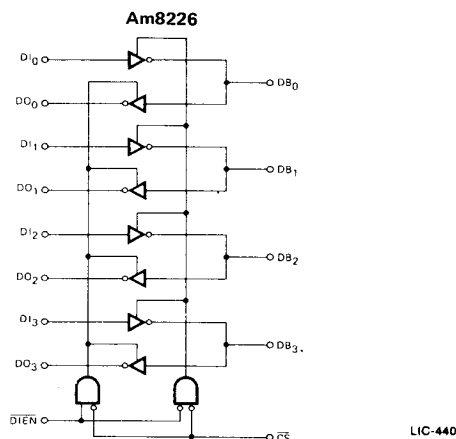
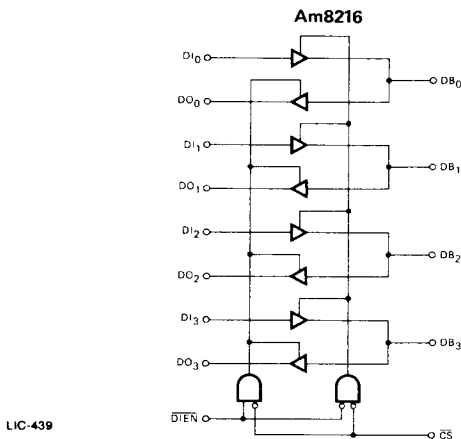

### ORDERING INFORMATION

Package Type	Temperature Range	Am8216 Order Number	Am8226 Order Number
Hermetic DIP	-55°C to +125°C	MD8216	MD8226
Hermetic DIP	0°C to +70°C	D8216	D8226
Molded DIP	0°C to +70°C	P8216	P8226
Dice	0°C to +70°C	AM8216XC	AM8226XC

### CONNECTION DIAGRAM Top View

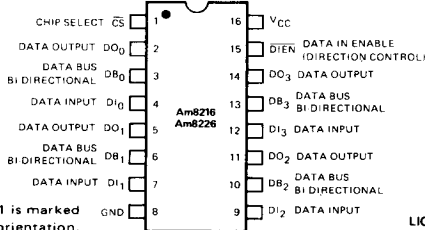

**MAXIMUM RATINGS** (Above which the useful life may be impaired)

Temperature (Ambient) Under Bias	-55°C to +125°C
Storage Temperature	-65°C to +150°C
All Output and Supply Voltages	-0.5V to +7.0V
All Input Voltages	-1.0V to +5.5V
Output Currents	125 mA

**Am8216 AND Am8226 MILITARY****ELECTRICAL CHARACTERISTICS OVER OPERATING TEMPERATURE RANGE** (-55°C to +125°C)

The following conditions apply unless otherwise specified:

MD8216, MD8226 (MIL)  $T_A = -55^\circ\text{C}$  to  $+125^\circ\text{C}$   $V_{CC} = 5.0\text{V} \pm 10\%$ **DC CHARACTERISTICS**

Parameters	Description	Test Conditions	Min.	Typ. (Note 1)	Max.	Units	
I <sub>F1</sub>	Input Load Current DIEN, CS	V <sub>F</sub> = 0.45		-0.15	-0.5	mA	
I <sub>F2</sub>	Input Load Current All Other Inputs	V <sub>F</sub> = 0.45		-0.08	-0.25	mA	
I <sub>R1</sub>	Input Leakage Current DIEN, CS	V <sub>R</sub> = 5.5V			80	μA	
I <sub>R2</sub>	Input Leakage Current DI Inputs	V <sub>R</sub> = 5.5V			40	μA	
V <sub>C</sub>	Input Forward Voltage Clamp	I <sub>C</sub> = -5.0mA			-1.2	Volts	
V <sub>IL</sub>	Input LOW Voltage	Am8216			0.95	Volts	
		Am8226			0.9		
V <sub>IH</sub>	Input HIGH Voltage		2.0			Volts	
I <sub>O</sub>	Output Leakage Current (Three-State)	DO	V <sub>O</sub> = 0.45V/5.5V			20	μA
		DB				100	
I <sub>CC</sub>	Power Supply Current	Am8216		95	130	mA	
		Am8226		85	120		
V <sub>OL1</sub>	Output LOW Voltage	DO Outputs I <sub>OL</sub> = 15mA DB Outputs I <sub>OL</sub> = 25mA		0.3	0.45	Volts	
V <sub>OL2</sub>	Output LOW Voltage	DB Outputs I <sub>OL</sub> = 45mA		0.5	0.6	Volts	
V <sub>OH1</sub>	Output HIGH Voltage	DO Outputs	I <sub>OH</sub> = -0.5mA	3.4	4.0	Volts	
			I <sub>OH</sub> = -2.0mA	2.4			
V <sub>OH2</sub>	Output HIGH Voltage	DB Outputs I <sub>OH</sub> = -5.0mA	2.4	3.0		Volts	
I <sub>OS</sub>	Output Short Circuit Current	DO Outputs $\approx 0\text{V}$ , V <sub>CC</sub> = 5.0V	-15	-35	-65	mA	
		DB Outputs = 0V, V <sub>CC</sub> = 5.0V	-30	-75	-120		

11

**AC CHARACTERISTICS OVER OPERATING TEMPERATURE RANGE** (-55°C to +125°C)

Parameters	Description	Test Conditions	Min.	Typ. (Note 1)	Max.	Units
t <sub>PD1</sub>	Input to Output Delay DO Outputs	C <sub>L</sub> = 30pF, R <sub>1</sub> = 300Ω, R <sub>2</sub> = 600Ω		15	25	ns
t <sub>PD2</sub>	Input to Output Delay DB Outputs	Am8216	C <sub>L</sub> = 300pF, R <sub>1</sub> = 90Ω, R <sub>2</sub> = 180Ω	20	33	ns
		Am8226		16	25	
t <sub>E</sub>	Output Enable Time	Am8216	Note 2	45	75	ns
		Am8226	Note 3	35	62	
t <sub>D</sub>	Output Disable Time	Am8216	Note 4	20	40	ns
		Am8226		16	38	

11-25

**Am8216 • Am8226**

**Am8216 AND Am8226 COMMERCIAL**

**ELECTRICAL CHARACTERISTICS OVER OPERATING TEMPERATURE RANGE (0°C to +70°C)**

The following conditions apply unless otherwise specified:

D8216, D8226, P8216, P8226 (COM'L)      $T_A = 0^\circ\text{C to } +70^\circ\text{C}$       $V_{CC} = 5.0\text{V} \pm 5\%$

**DC CHARACTERISTICS**

Parameters	Description	Test Conditions	Min.	Typ. (Note 1)	Max.	Units
I <sub>F1</sub>	Input Load Current DIEN, CS	V <sub>F</sub> = 0.45		-0.15	-0.5	mA
I <sub>F2</sub>	Input Load Current All Other Inputs	V <sub>F</sub> = 0.45		-0.08	-0.25	mA
I <sub>R1</sub>	Input Leakage Current DIEN, CS	V <sub>R</sub> = 5.25V			20	μA
I <sub>R2</sub>	Input Leakage Current DI Inputs	V <sub>R</sub> = 5.25V			10	μA
V <sub>C</sub>	Input Forward Voltage Clamp	I <sub>C</sub> = -5.0mA			-1.0	Volts
V <sub>IL</sub>	Input LOW Voltage				0.95	Volts
V <sub>IH</sub>	Input HIGH Voltage		2.0			Volts
I <sub>OL</sub>	Output Leakage Current (Three-State)	DO	V <sub>O</sub> = 0.45V/5.5V		20	μA
		DB			100	
I <sub>CC</sub>	Power Supply Current	Am8216		95	130	mA
		Am8226		85	120	
V <sub>OL1</sub>	Output LOW Voltage	DB Outputs I <sub>OL</sub> = 15mA DB Outputs I <sub>OL</sub> = 25mA		0.3	0.45	Volts
V <sub>OL2</sub>	Output LOW Voltage	Am8216		0.5	0.6	Volts
		Am8226	DB Outputs I <sub>OL</sub> = 50mA	0.5	0.6	
V <sub>OH1</sub>	Output HIGH Voltage	DO Outputs I <sub>OH</sub> = -1.0mA COM'L	3.65	4.0		Volts
V <sub>OH2</sub>	Output HIGH Voltage	DB Outputs I <sub>OH</sub> = -10mA	2.4	3.0		Volts
I <sub>OS</sub>	Output Short Circuit Current	DO Outputs $\approx 0\text{V}$	-15	-35	-65	mA
		DB Outputs V <sub>CC</sub> = 5.0V	-30	-75	-120	

**AC CHARACTERISTICS OVER OPERATING TEMPERATURE RANGE (0°C to +70°C)**

Parameters	Description	Test Conditions	Min.	Typ. (Note 1)	Max.	Units
t <sub>PD1</sub>	Input to Output Delay DO Outputs	C <sub>L</sub> = 30pF, R <sub>1</sub> = 300Ω, R <sub>2</sub> = 600Ω		15	25	ns
t <sub>PD2</sub>	Input to Output Delay DB Outputs	Am8216		20	30	ns
		Am8226	C <sub>L</sub> = 300pF, R <sub>1</sub> = 90Ω, R <sub>2</sub> = 180Ω	16	25	
t <sub>E</sub>	Output Enable Time	Am8216	Note 2	45	65	ns
		Am8226	Note 3	35	54	
t <sub>D</sub>	Output Disable Time	Note 4		20	35	ns

**TEST CONDITIONS**

Input pulse amplitude of 2.5V.  
 Input rise and fall times of 5.0ns between 1.0 and 2.0 volts.  
 Output loading is 5.0mA and 10pF.  
 Speed measurements are made at 1.5V levels.

**TEST LOAD CIRCUIT**

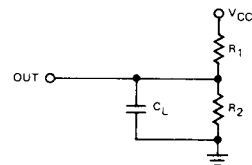

LIC-442

**CAPACITANCE (Note 5)**

Parameters	Description	Test Conditions	Min.	Typ. (Note 1)	Max.	Units
C <sub>IN</sub>	Input Capacitance	V <sub>BIAS</sub> = 2.5V, V <sub>CC</sub> = 5.0V T <sub>A</sub> = 25°C, f = 1.0MHz		4.0	8.0	pF
C <sub>OUT1</sub>	Output Capacitance			6.0	10	pF
C <sub>OUT2</sub>	Output Capacitance			13	18	pF

- Notes: 1. Typical values are for T<sub>A</sub> = 25°C, V<sub>CC</sub> = 5.0V.  
 2. DO outputs, C<sub>L</sub> = 30pF, R<sub>1</sub> = 300/10kΩ, R<sub>2</sub> = 180/1.0kΩ; DB outputs, C<sub>L</sub> = 300pF, R<sub>1</sub> = 90/10kΩ, R<sub>2</sub> = 180/1.0kΩ.  
 3. DO outputs, C<sub>L</sub> = 30pF, R<sub>1</sub> = 300/10kΩ, R<sub>2</sub> = 600/1.0kΩ; DB outputs, C<sub>L</sub> = 300pF, R<sub>1</sub> = 90/10kΩ, R<sub>2</sub> = 180/1.0kΩ.  
 4. DO outputs, C<sub>L</sub> = 5.0pF, R<sub>1</sub> = 300/10kΩ, R<sub>2</sub> = 600/1.0kΩ; DB outputs, C<sub>L</sub> = 5.0pF, R<sub>1</sub> = 90/10kΩ, R<sub>2</sub> = 180/1.0kΩ.  
 5. This parameter is periodically sampled and not 100% tested.

**SWITCHING WAVEFORMS**

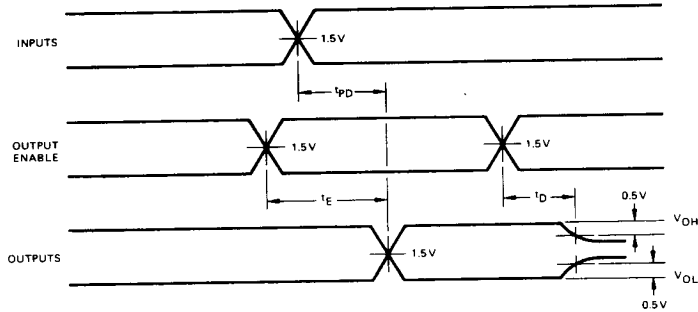

LIC-443

**FUNCTION TABLE**

DIEN	CS		8216		8226	
			DB	DO	DB	DO
L	L	DI = DB	DI	Z	$\overline{DI}$	Z
H	L	DB = DO	Z	DB	Z	$\overline{DB}$
L	H		Z	Z	Z	Z
H	H		Z	Z	Z	Z

H = HIGH  
L = LOW

LIC-444

**TYPICAL APPLICATION**

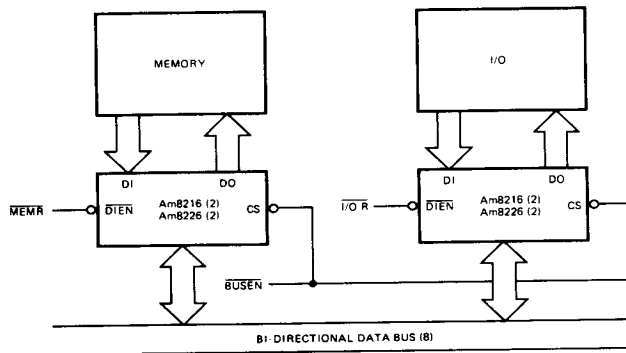

**MEMORY AND I/O INTERFACE TO A BI-DIRECTIONAL BUS**

LIC-445

**Metallization and Pad Layout**

**Am8216**

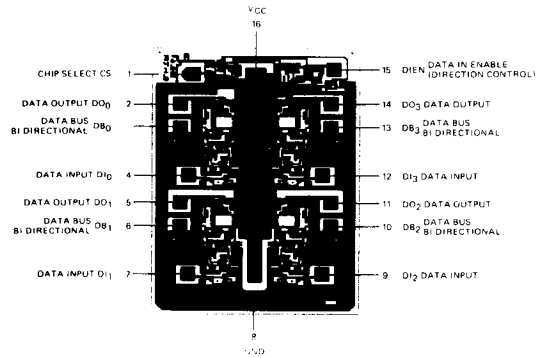

DIE SIZE 0.066" X 0.090"

**Am8226**

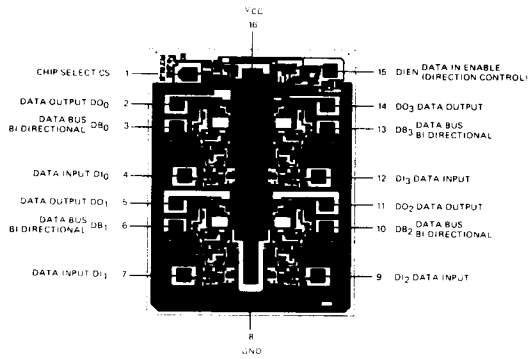

DIE SIZE 0.066" X 0.090"