

**CD4020BM/CD4020BC**  
**14-Stage Ripple Carry Binary Counters**  
**CD4040BM/CD4040BC**  
**12-Stage Ripple Carry Binary Counters**  
**CD4060BM/CD4060BC**  
**14-Stage Ripple Carry Binary Counters**

**General Description**

The CD4020BM/CD4020BC, CD4060BM/CD4060BC are 14-stage ripple carry binary counters, and the CD4040BM/CD4040BC is a 12-stage ripple carry binary counter. The counters are advanced one count on the negative transition of each clock pulse. The counters are reset to the zero state by a logical "1" at the reset input independent of clock.

**Features**

- Wide supply voltage range 1.0V to 15V
- High noise immunity 0.45 V<sub>DD</sub> (typ.)
- Low power TTL compatibility Fan out of 2 driving 74L or 1 driving 74LS
- Medium speed operation 8 MHz typ. at V<sub>DD</sub> = 10V
- Schmitt trigger clock input

**Connection Diagrams**

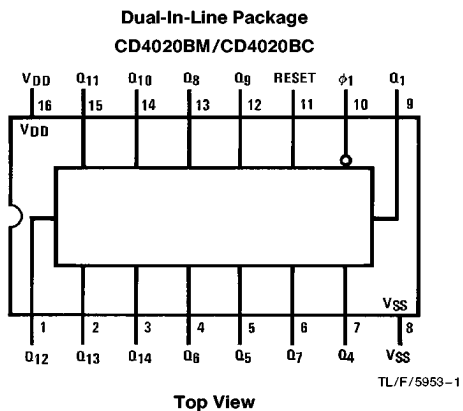

Order Number CD4020B, CD4040B or CD4060B

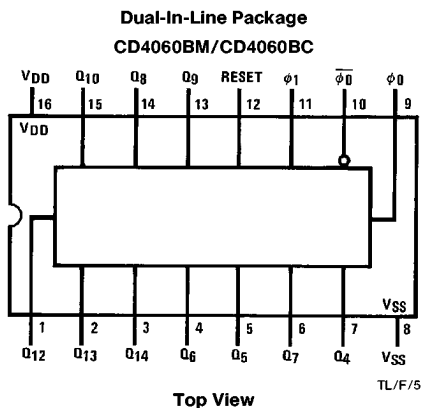
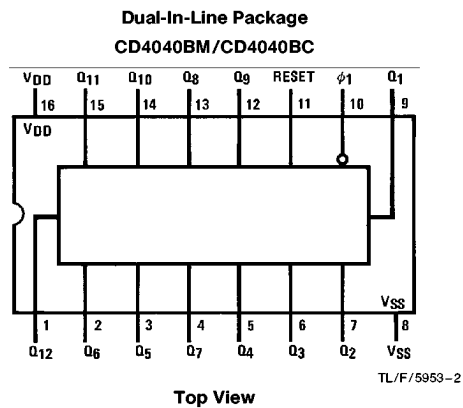

CD4020BM/BC 14-Stage Ripple Carry Binary Counters/CD4040BM/BC 12-Stage Ripple Carry Binary Counters/CD4060BM/BC 14-Stage Ripple Carry Binary Counters

### Absolute Maximum Ratings (Notes 1 and 2)

If Military/Aerospace specified devices are required, please contact the National Semiconductor Sales Office/Distributors for availability and specifications.

Supply Voltage ( $V_{DD}$ )	-0.5V to +18V
Input Voltage ( $V_{IN}$ )	-0.5V to $V_{DD}$ + 0.5V
Storage Temperature Range ( $T_S$ )	-65°C to +150°C
Package Dissipation ( $P_D$ )	
Dual-In-Line	700 mW
Small Outline	500 mW
Lead Temperature ( $T_L$ )	
(Soldering, 10 seconds)	260°C

### Recommended Operating Conditions

Supply Voltage ( $V_{DD}$ )	+3V to +15V
Input Voltage ( $V_{IN}$ )	0V to $V_{DD}$
Operating Temperature Range ( $T_A$ )	
CD40XXBM	-55°C to +125°C
CD40XXBC	-40°C to +85°C

### DC Electrical Characteristics CD40XXBM (Note 2)

Symbol	Parameter	Conditions	-55°C		+25°C			+125°C		Units
			Min	Max	Min	Typ	Max	Min	Max	
$I_{DD}$	Quiescent Device Current	$V_{DD} = 5V, V_{IN} = V_{DD}$ or $V_{SS}$		5			5		150	$\mu A$
		$V_{DD} = 10V, V_{IN} = V_{DD}$ or $V_{SS}$		10			10		300	$\mu A$
		$V_{DD} = 15V, V_{IN} = V_{DD}$ or $V_{SS}$		20			20		600	$\mu A$
$V_{OL}$	Low Level Output Voltage	$V_{DD} = 5V$		0.05		0	0.05		0.05	V
		$V_{DD} = 10V$		0.05		0	0.05		0.05	V
		$V_{DD} = 15V$		0.05		0	0.05		0.05	V
$V_{OH}$	High Level Output Voltage	$V_{DD} = 5V$	4.95		4.95	5		4.95		V
		$V_{DD} = 10V$	9.95		9.95	10		9.95		V
		$V_{DD} = 15V$	14.95		14.95	15		14.95		V
$V_{IL}$	Low Level Input Voltage	$V_{DD} = 5V, V_O = 0.5V$ or 4.5V		1.5		2	1.5		1.5	V
		$V_{DD} = 10V, V_O = 1.0V$ or 9.0V		3.0		4	3.0		3.0	V
		$V_{DD} = 15V, V_O = 1.5V$ or 13.5V		4.0		6	4.0		4.0	V
$V_{IH}$	High Level Input Voltage	$V_{DD} = 5V, V_O = 0.5V$ or 4.5V	3.5		3.5	3		3.5		V
		$V_{DD} = 10V, V_O = 1.0V$ or 9.0V	7.0		7.0	6		7.0		V
		$V_{DD} = 15V, V_O = 1.5V$ or 13.5V	11.0		11.0	9		11.0		V
$I_{OL}$	Low Level Output Current (See Note 3)	$V_{DD} = 5V, V_O = 0.4V$	0.64		0.51	0.88		0.36		mA
		$V_{DD} = 10V, V_O = 0.5V$	1.6		1.3	2.25		0.9		mA
		$V_{DD} = 15V, V_O = 1.5V$	4.2		3.4	8.8		2.4		mA
$I_{OH}$	High Level Output Current (See Note 3)	$V_{DD} = 5V, V_O = 4.6V$	-0.64		-0.51	-0.88		-0.36		mA
		$V_{DD} = 10V, V_O = 9.5V$	-1.6		-1.3	-2.25		-0.9		mA
		$V_{DD} = 15V, V_O = 13.5V$	-4.2		-3.4	-8.8		-2.4		mA
$I_{IN}$	Input Current	$V_{DD} = 15V, V_{IN} = 0V$		-0.10		$-10^{-5}$	-0.10		-1.0	$\mu A$
		$V_{DD} = 15V, V_{IN} = 15V$		0.10		$10^{-5}$	0.10		1.0	$\mu A$

**Note 1:** "Absolute Maximum Ratings" are those values beyond which the safety of the device cannot be guaranteed. They are not meant to imply that the devices should be operated at these limits. The tables of "Recommended Operating Conditions" and "Electrical Characteristics" provide conditions for actual device operation.

**Note 2:**  $V_{SS} = 0V$  unless otherwise specified.

**Note 3:** Data does not apply to oscillator points  $\phi_0$  and  $\bar{\phi}_0$  of CD4060BM/CD4060BC.  $I_{OH}$  and  $I_{OL}$  are tested one output at a time.

### DC Electrical Characteristics 40XXBC (Note 2)

Symbol	Parameter	Conditions	-40°C		+25°C			+85°C		Units
			Min	Max	Min	Typ	Max	Min	Max	
$I_{DD}$	Quiescent Device Current	$V_{DD} = 5V, V_{IN} = V_{DD}$ or $V_{SS}$		20			20		150	$\mu A$
		$V_{DD} = 10V, V_{IN} = V_{DD}$ or $V_{SS}$		40			40		300	$\mu A$
		$V_{DD} = 15V, V_{IN} = V_{DD}$ or $V_{SS}$		80			80		600	$\mu A$
$V_{OL}$	Low Level Output Voltage	$V_{DD} = 5V$		0.05		0	0.05		0.05	V
		$V_{DD} = 10V$		0.05		0	0.05		0.05	V
		$V_{DD} = 15V$		0.05		0	0.05		0.05	V

### DC Electrical Characteristics 40XXBC (Note 2) (Continued)

Symbol	Parameter	Conditions	- 40°C		+ 25°C			+ 85°C		Units
			Min	Max	Min	Typ	Max	Min	Max	
V <sub>OH</sub>	High Level Output Voltage	V <sub>DD</sub> = 5V	4.95		4.95	5		4.95		V
		V <sub>DD</sub> = 10V	9.95		9.95	10		9.95		V
		V <sub>DD</sub> = 15V	14.95		14.95	15		14.95		V
V <sub>IL</sub>	Low Level Input Voltage	V <sub>DD</sub> = 5V, V <sub>O</sub> = 0.5V or 4.5V		1.5		2	1.5		1.5	V
		V <sub>DD</sub> = 10V, V <sub>O</sub> = 1.0V or 9.0V		3.0		4	3.0		3.0	V
		V <sub>DD</sub> = 15V, V <sub>O</sub> = 1.5V or 13.5V		4.0		6	4.0		4.0	V
V <sub>IH</sub>	High Level Input Voltage	V <sub>DD</sub> = 5V, V <sub>O</sub> = 0.5V or 4.5V	3.5		3.5	3		3.5		V
		V <sub>DD</sub> = 10V, V <sub>O</sub> = 1.0V or 9.0V	7.0		7.0	6		7.0		V
		V <sub>DD</sub> = 15V, V <sub>O</sub> = 1.5V or 13.5V	11.0		11.0	9		11.0		V
I <sub>OL</sub>	Low Level Output Current (See Note 3)	V <sub>DD</sub> = 5V, V <sub>O</sub> = 0.4V	0.52		0.44	0.88		0.36		mA
		V <sub>DD</sub> = 10V, V <sub>O</sub> = 0.5V	1.3		1.1	2.25		0.9		mA
		V <sub>DD</sub> = 15V, V <sub>O</sub> = 1.5V	3.6		3.0	8.8		2.4		mA
I <sub>OH</sub>	High Level Output Current (See Note 3)	V <sub>DD</sub> = 5V, V <sub>O</sub> = 4.6V	-0.52		-0.44	-0.88		-0.36		mA
		V <sub>DD</sub> = 10V, V <sub>O</sub> = 9.5V	-1.3		-1.1	-2.25		-0.9		mA
		V <sub>DD</sub> = 15V, V <sub>O</sub> = 13.5V	-3.6		-3.0	-8.8		-2.4		mA
I <sub>IN</sub>	Input Current	V <sub>DD</sub> = 15V, V <sub>IN</sub> = 0V		-0.30		-10 <sup>-5</sup>	-0.30		-1.0	μA
		V <sub>DD</sub> = 15V, V <sub>IN</sub> = 15V		0.30		10 <sup>-5</sup>	0.30		1.0	μA

### AC Electrical Characteristics\* CD4020BM/CD4020BC, CD4040BM/CD4040BC

T<sub>A</sub> = 25°C, C<sub>L</sub> = 50 pF, R<sub>L</sub> = 200k, t<sub>r</sub> = t<sub>f</sub> = 20 ns, unless otherwise noted

Symbol	Parameter	Conditions	Min	Typ	Max	Units
t <sub>PHL1</sub> , t <sub>PLH1</sub>	Propagation Delay Time to Q <sub>1</sub>	V <sub>DD</sub> = 5V		250	550	ns
		V <sub>DD</sub> = 10V		100	210	ns
		V <sub>DD</sub> = 15V		75	150	ns
t <sub>PHL</sub> , t <sub>PLH</sub>	Interstage Propagation Delay Time from Q <sub>n</sub> to Q <sub>n+1</sub>	V <sub>DD</sub> = 5V		150	330	ns
		V <sub>DD</sub> = 10V		60	125	ns
		V <sub>DD</sub> = 15V		45	90	ns
t <sub>THL</sub> , t <sub>TLH</sub>	Transition Time	V <sub>DD</sub> = 5V		100	200	ns
		V <sub>DD</sub> = 10V		50	100	ns
		V <sub>DD</sub> = 15V		40	80	ns
t <sub>WL</sub> , t <sub>WH</sub>	Minimum Clock Pulse Width	V <sub>DD</sub> = 5V		125	335	ns
		V <sub>DD</sub> = 10V		50	125	ns
		V <sub>DD</sub> = 15V		40	100	ns
t <sub>rCL</sub> , t <sub>fCL</sub>	Maximum Clock Rise and Fall Time	V <sub>DD</sub> = 5V			No Limit	ns
		V <sub>DD</sub> = 10V			No Limit	ns
		V <sub>DD</sub> = 15V			No Limit	ns
f <sub>CL</sub>	Maximum Clock Frequency	V <sub>DD</sub> = 5V	1.5	4		MHz
		V <sub>DD</sub> = 10V	4	10		MHz
		V <sub>DD</sub> = 15V	5	12		MHz
t <sub>PHL(R)</sub>	Reset Propagation Delay	V <sub>DD</sub> = 5V		200	450	ns
		V <sub>DD</sub> = 10V		100	210	ns
		V <sub>DD</sub> = 15V		80	170	ns
t <sub>WH(R)</sub>	Minimum Reset Pulse Width	V <sub>DD</sub> = 5V		200	450	ns
		V <sub>DD</sub> = 10V		100	210	ns
		V <sub>DD</sub> = 15V		80	170	ns
C <sub>in</sub>	Average Input Capacitance	Any Input		5	7.5	pF
C <sub>pd</sub>	Power Dissipation Capacitance			50		pF

\*AC Parameters are guaranteed by DC correlated testing.

## AC Electrical Characteristics\* CD4060BM/CD4060BC

T<sub>A</sub> = 25°C, C<sub>L</sub> = 50 pF, R<sub>L</sub> = 200k, t<sub>r</sub> = t<sub>f</sub> = 20 ns, unless otherwise noted

Symbol	Parameter	Conditions	Min	Typ	Max	Units
t <sub>PHL4</sub> , t <sub>PLH4</sub>	Propagation Delay Time to Q <sub>4</sub>	V <sub>DD</sub> = 5V V <sub>DD</sub> = 10V V <sub>DD</sub> = 15V		550 250 200	1300 525 400	ns ns ns
t <sub>PHL</sub> , t <sub>PLH</sub>	Interstage Propagation Delay Time from Q <sub>n</sub> to Q <sub>n+1</sub>	V <sub>DD</sub> = 5V V <sub>DD</sub> = 10V V <sub>DD</sub> = 15V		150 60 45	330 125 90	ns ns ns
t <sub>THL</sub> , t <sub>TLH</sub>	Transition Time	V <sub>DD</sub> = 5V V <sub>DD</sub> = 10V V <sub>DD</sub> = 15V		100 50 40	200 100 80	ns ns ns
t <sub>WL</sub> , t <sub>WH</sub>	Minimum Clock Pulse Width	V <sub>DD</sub> = 5V V <sub>DD</sub> = 10V V <sub>DD</sub> = 15V		170 65 50	500 170 125	ns ns ns
t <sub>rCL</sub> , t <sub>fCL</sub>	Maximum Clock Rise and Fall Time	V <sub>DD</sub> = 5V V <sub>DD</sub> = 10V V <sub>DD</sub> = 15V			No Limit No Limit No Limit	ns ns ns
f <sub>CL</sub>	Maximum Clock Frequency	V <sub>DD</sub> = 5V V <sub>DD</sub> = 10V V <sub>DD</sub> = 15V	1 3 4	3 8 10		MHz MHz MHz
t <sub>PHL(R)</sub>	Reset Propagation Delay	V <sub>DD</sub> = 5V V <sub>DD</sub> = 10V V <sub>DD</sub> = 15V		200 100 80	450 210 170	ns ns ns
t <sub>WH(R)</sub>	Minimum Reset Pulse Width	V <sub>DD</sub> = 5V V <sub>DD</sub> = 10V V <sub>DD</sub> = 15V		200 100 80	450 210 170	ns ns ns
C <sub>in</sub>	Average Input Capacitance	Any Input		5	7.5	pF
C <sub>pd</sub>	Power Dissipation Capacitance			50		pF

\*AC Parameters are guaranteed by DC correlated testing.

## CD4060B Typical Oscillator Connections

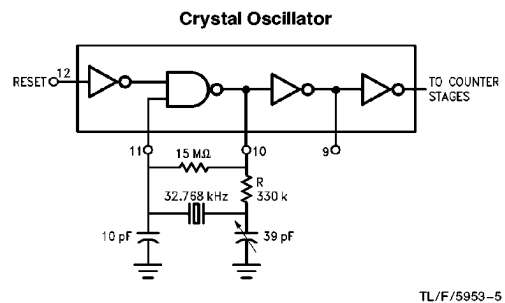
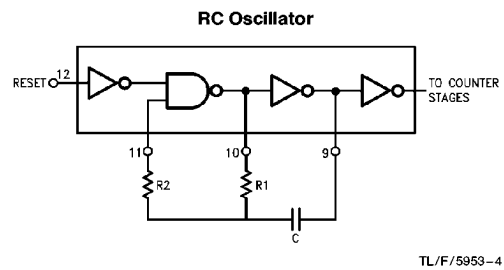

## Schematic Diagrams

CD4020BM/CD4020BC Schematic Diagram

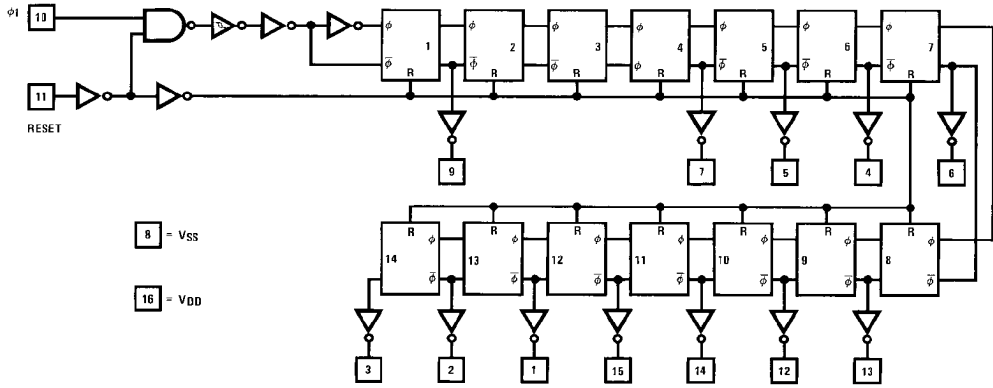

CD4040BM/CD4040BC Schematic Diagram

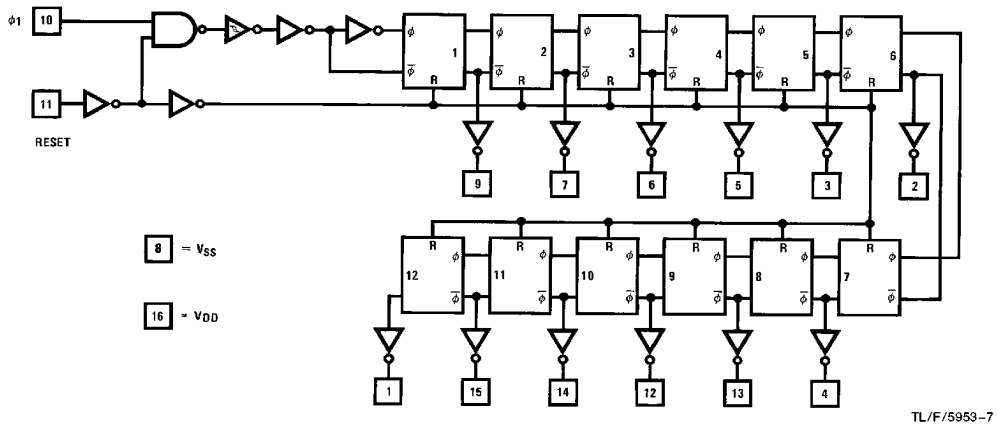

CD4060BM/CD4060BC Schematic Diagram

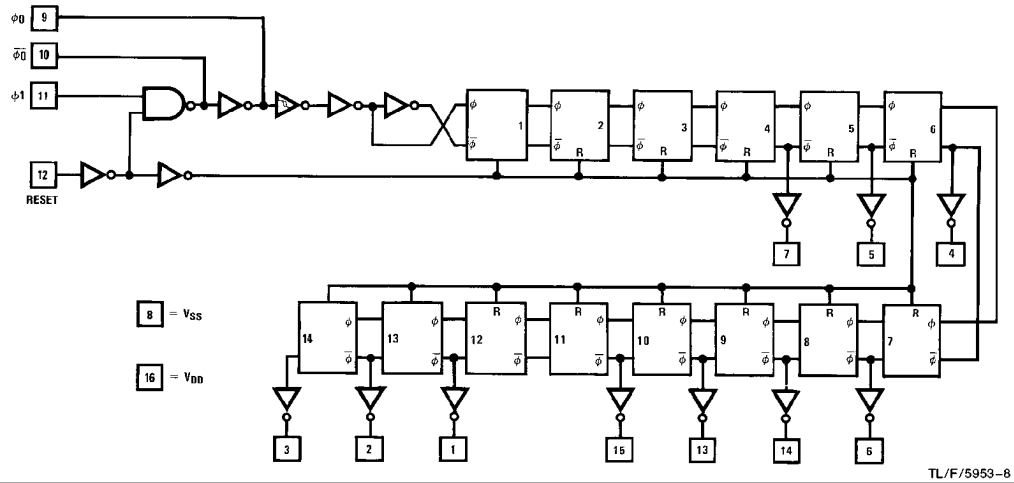

**CD4020BM/BC 14-Stage Ripple Carry Binary Counters/CD4040BM/BC 12-Stage Ripple Carry Binary Counters**  
**CD4060BM/BC 14-Stage Ripple Carry Binary Counters**

**Physical Dimensions inches (millimeters)**

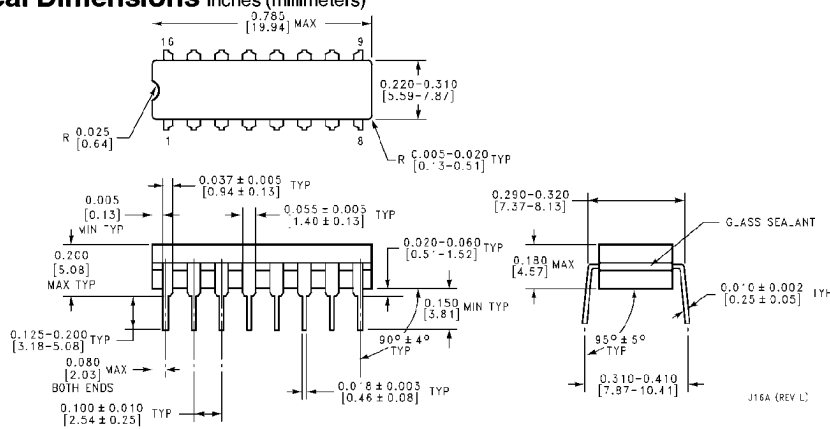

**Ceramic Dual-In-Line Package (J)**  
**Order Number CD4020BMJ, CD4020BCJ,**  
**CD4040BMJ, CD4040BCJ, CD4060BMJ or CD4060BCJ**  
**NS Package Number J16A**

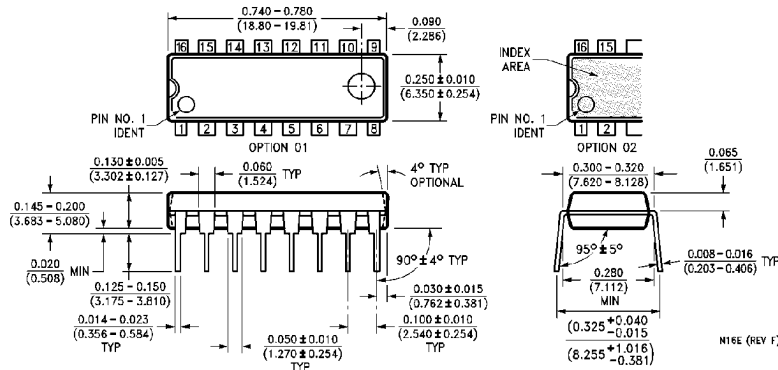

**Molded Dual-In-Line Package (N)**  
**Order Number CD4020BMN, CD4020BCN,**  
**CD4040BMN, CD4040BCN, CD4060BMN or CD4060BCN**  
**NS Package Number N16E**

**LIFE SUPPORT POLICY**

NATIONAL'S PRODUCTS ARE NOT AUTHORIZED FOR USE AS CRITICAL COMPONENTS IN LIFE SUPPORT DEVICES OR SYSTEMS WITHOUT THE EXPRESS WRITTEN APPROVAL OF THE PRESIDENT OF NATIONAL SEMICONDUCTOR CORPORATION. As used herein:

1. Life support devices or systems are devices or systems which, (a) are intended for surgical implant into the body, or (b) support or sustain life, and whose failure to perform, when properly used in accordance with instructions for use provided in the labeling, can be reasonably expected to result in a significant injury to the user.
2. A critical component is any component of a life support device or system whose failure to perform can be reasonably expected to cause the failure of the life support device or system, or to affect its safety or effectiveness.



**National Semiconductor Corporation**  
 1111 West Bardin Road  
 Arlington, TX 76017  
 Tel: 1(800) 272-9959  
 Fax: 1(800) 737-7018

**National Semiconductor Europe**  
 Fax: (+49) 0-180-530 85 86  
 Email: cnjwge@tevm2.nsc.com  
 Deutsch Tel: (+49) 0-180-530 85 85  
 English Tel: (+49) 0-180-532 78 32  
 Français Tel: (+49) 0-180-532 93 58  
 Italiano Tel: (+49) 0-180-534 16 80

**National Semiconductor Hong Kong Ltd.**  
 13th Floor, Straight Block,  
 Ocean Centre, 5 Canton Rd.  
 Tsimshatsui, Kowloon  
 Hong Kong  
 Tel: (852) 2737-1600  
 Fax: (852) 2736-9960

**National Semiconductor Japan Ltd.**  
 Tel: 81-043-299-2309  
 Fax: 81-043-299-2406

National does not assume any responsibility for use of any circuitry described, no circuit patent licenses are implied and National reserves the right at any time without notice to change said circuitry and specifications.