

## CD4027BM/CD4027BC Dual J-K Master/Slave Flip-Flop with Set and Reset

### General Description

These dual J-K flip-flops are monolithic complementary MOS (CMOS) integrated circuits constructed with N- and P-channel enhancement mode transistors. Each flip-flop has independent J, K, set, reset, and clock inputs and buffered Q and  $\bar{Q}$  outputs. These flip-flops are edge sensitive to the clock input and change state on the positive-going transition of the clock pulses. Set or reset is independent of the clock and is accomplished by a high level on the respective input. All inputs are protected against damage due to static discharge by diode clamps to  $V_{DD}$  and  $V_{SS}$ .

### Features

- Wide supply voltage range 3.0V to 15V
- High noise immunity 0.45  $V_{DD}$  (typ.)
- Low power TTL compatibility Fan out of 2 driving 74L or 1 driving 74LS
- Low power 50 nW (typ.)
- Medium speed operation 12 MHz (typ.) with 10V supply

### Schematic and Connection Diagrams

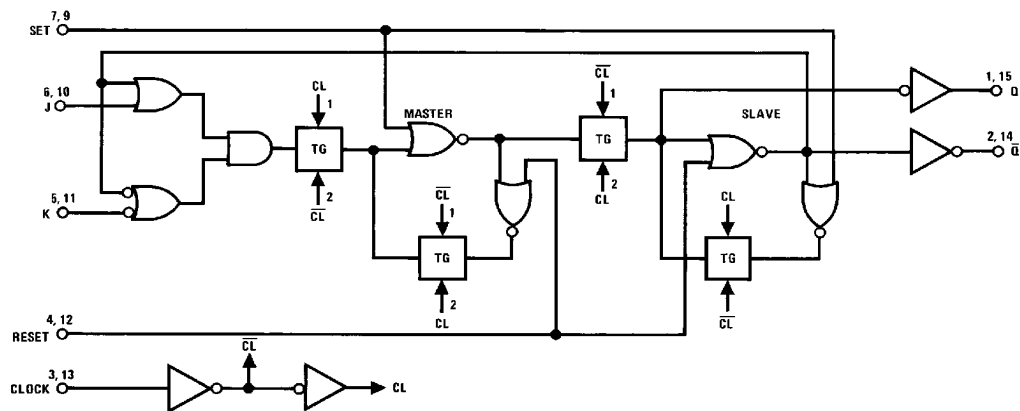

TL/F/5958-1

#### Dual-In-Line Package

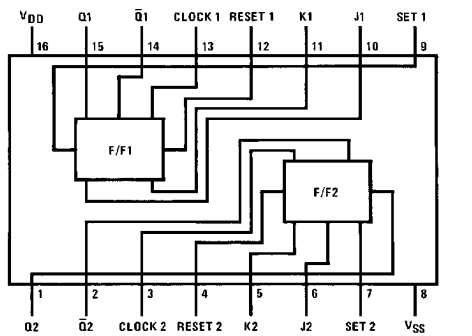

#### Top View

TL/F/5958-2

Order Number CD4027B

CD4027BM/CD4027BC Dual J-K Master/Slave Flip-Flop with Set and Reset

### Absolute Maximum Ratings (Note 1 and 2)

If Military/Aerospace specified devices are required, please contact the National Semiconductor Sales Office/Distributors for availability and specifications.

DC Supply Voltage ( $V_{DD}$ )	-0.5 $V_{DC}$ to +18 $V_{DC}$
Input Voltage ( $V_{IN}$ )	-0.5V to $V_{DD}$ +0.5 $V_{DC}$
Storage Temperature Range ( $T_S$ )	-65°C to +150°C
Power Dissipation ( $P_D$ )	
Dual-In-Line	700 mW
Small Outline	500 mW
Lead Temperature ( $T_L$ )	
(Soldering, 10 seconds)	260°C

### Recommended Operating Conditions (Note 2)

DC Supply Voltage ( $V_{DD}$ )	3V to 15 $V_{DC}$
Input Voltage ( $V_{IN}$ )	0V to $V_{DD}$ $V_{DC}$
Operating Temperature Range ( $T_A$ )	
CD4027BM	-55°C to +125°C
CD4027BC	-40°C to +85°C

### DC Electrical Characteristics CD4027BM (Note 2)

Symbol	Parameter	Conditions	-55°C		+25°C			+125°C		Units
			Min	Max	Min	Typ	Max	Min	Max	
$I_{DD}$	Quiescent Device Current	$V_{DD} = 5V, V_{IN} = V_{DD}$ or $V_{SS}$		1			1		30	$\mu A$
		$V_{DD} = 10V, V_{IN} = V_{DD}$ or $V_{SS}$		2			2		60	$\mu A$
		$V_{DD} = 15V, V_{IN} = V_{DD}$ or $V_{SS}$		4			4		120	$\mu A$
$V_{OL}$	Low Level Output Voltage	$ I_O  < 1 \mu A$								
		$V_{DD} = 5V$		0.05		0	0.05		0.05	V
		$V_{DD} = 10V$		0.05		0	0.05		0.05	V
		$V_{DD} = 15V$		0.05		0	0.05		0.05	V
$V_{OH}$	High Level Output Voltage	$ I_O  < 1 \mu A$								
		$V_{DD} = 5V$	4.95		4.95	5		4.95		V
		$V_{DD} = 10V$	9.95		9.95	10		9.95		V
		$V_{DD} = 15V$	14.95		14.95	15		14.95		V
$V_{IL}$	Low Level Input Voltage	$V_{DD} = 5V, V_O = 0.5V$ or $4.5V$		1.5			1.5		1.5	V
		$V_{DD} = 10V, V_O = 1V$ or $9V$		3.0			3.0		3.0	V
		$V_{DD} = 15V, V_O = 1.5V$ or $13.5V$		4.0			4.0		4.0	V
$V_{IH}$	High Level Input Voltage	$V_{DD} = 5V, V_O = 0.5V$ or $4.5V$	3.5		3.5			3.5		V
		$V_{DD} = 10V, V_O = 1V$ or $9V$	7.0		7.0			7.0		V
		$V_{DD} = 15V, V_O = 1.5V$ or $13.5V$	11.0		11.0			11.0		V
$I_{OL}$	Low Level Output Current (Note 3)	$V_{DD} = 5V, V_O = 0.4V$	0.64		0.51	0.88		0.36		mA
		$V_{DD} = 10V, V_O = 0.5V$	1.6		1.3	2.25		0.9		mA
		$V_{DD} = 15V, V_O = 1.5V$	4.2		3.4	8.8		2.4		mA
$I_{OH}$	High Level Output Current (Note 3)	$V_{DD} = 5V, V_O = 4.6V$	-0.64		-0.51	-0.88		-0.36		mA
		$V_{DD} = 10V, V_O = 9.5V$	-1.6		-1.3	-2.25		-0.9		mA
		$V_{DD} = 15V, V_O = 13.5V$	-4.2		-3.4	-8.8		-2.4		mA
$I_{IN}$	Input Current	$V_{DD} = 15V, V_{IN} = 0V$		-0.1		$-10^{-5}$	-0.1		-1.0	$\mu A$
		$V_{DD} = 15V, V_{IN} = 15V$		0.1		$10^{-5}$	0.1		1.0	$\mu A$

**Note 1:** "Absolute Maximum Ratings" are those values beyond which the safety of the device cannot be guaranteed. They are not meant to imply that the devices should be operated at these limits. The table of "Recommended Operating Conditions" and "Electrical Characteristics" provides conditions for actual device operation.

**Note 2:**  $V_{SS} = 0V$  unless otherwise specified.

**Note 3:**  $I_{OH}$  and  $I_{OL}$  are tested one output at a time.

## DC Electrical Characteristics CD4027BC (Note 2)

Symbol	Parameter	Conditions	- 40°C		+ 25°C			+ 85°C		Units
			Min	Max	Min	Typ	Max	Min	Max	
I <sub>DD</sub>	Quiescent Device Current	V <sub>DD</sub> = 5V, V <sub>IN</sub> = V <sub>DD</sub> or V <sub>SS</sub>		4			4		30	μA
		V <sub>DD</sub> = 10V, V <sub>IN</sub> = V <sub>DD</sub> or V <sub>SS</sub>		8			8		60	μA
		V <sub>DD</sub> = 15V, V <sub>IN</sub> = V <sub>DD</sub> or V <sub>SS</sub>		16			16		120	μA
V <sub>OL</sub>	Low Level Output Voltage	I <sub>O</sub>   < 1 μA								
		V <sub>DD</sub> = 5V		0.05		0	0.05		0.05	V
		V <sub>DD</sub> = 10V		0.05		0	0.05		0.05	V
		V <sub>DD</sub> = 15V		0.05		0	0.05		0.05	V
V <sub>OH</sub>	High Level Output Voltage	I <sub>O</sub>   < 1 μA								
		V <sub>DD</sub> = 5V	4.95		4.95	5		4.95		V
		V <sub>DD</sub> = 10V	9.95		9.95	10		9.95		V
		V <sub>DD</sub> = 15V	14.95		14.95	15		14.95		V
V <sub>IL</sub>	Low Level Input Voltage	V <sub>DD</sub> = 5V, V <sub>O</sub> = 0.5V or 4.5V		1.5			1.5		1.5	V
		V <sub>DD</sub> = 10V, V <sub>O</sub> = 1V or 9V		3.0			3.0		3.0	V
		V <sub>DD</sub> = 15V, V <sub>O</sub> = 1.5V or 13.5V		4.0			4.0		4.0	V
V <sub>IH</sub>	High Level Input Voltage	V <sub>DD</sub> = 5V, V <sub>O</sub> = 0.5V or 4.5V	3.5		3.5			3.5		V
		V <sub>DD</sub> = 10V, V <sub>O</sub> = 1V or 9V	7.0		7.0			7.0		V
		V <sub>DD</sub> = 15V, V <sub>O</sub> = 1.5V or 13.5V	11.0		11.0			11.0		V
I <sub>OL</sub>	Low Level Output Current (Note 3)	V <sub>DD</sub> = 5V, V <sub>O</sub> = 0.4V	0.52		0.44	0.88		0.36		mA
		V <sub>DD</sub> = 10V, V <sub>O</sub> = 0.5V	1.3		1.1	2.25		0.9		mA
		V <sub>DD</sub> = 15V, V <sub>O</sub> = 1.5V	3.6		3.0	8.8		2.4		mA
I <sub>OH</sub>	High Level Output Current (Note 3)	V <sub>DD</sub> = 5V, V <sub>O</sub> = 4.6V	-0.52		-0.44	-0.88		-0.36		mA
		V <sub>DD</sub> = 10V, V <sub>O</sub> = 9.5V	-1.3		-1.1	-2.25		-0.9		mA
		V <sub>DD</sub> = 15V, V <sub>O</sub> = 13.5V	-3.6		-3.0	-8.8		-2.4		mA
I <sub>IN</sub>	Input Current	V <sub>DD</sub> = 15V, V <sub>IN</sub> = 0V		-0.3		-10 <sup>-5</sup>	-0.3		-1.0	μA
		V <sub>DD</sub> = 15V, V <sub>IN</sub> = 15V		0.3		10 <sup>-5</sup>	0.3		1.0	μA

**Note 1:** "Absolute Maximum Ratings" are those values beyond which the safety of the device cannot be guaranteed. They are not meant to imply that the devices should be operated at these limits. The table of "Recommended Operating Conditions" and "Electrical Characteristics" provides conditions for actual device operation.

**Note 2:** V<sub>SS</sub> = 0V unless otherwise specified.

**Note 3:** I<sub>OH</sub> and I<sub>OL</sub> are tested one output at a time.

**AC Electrical Characteristics\***  $T_A = 25^\circ\text{C}$ ,  $C_L = 50\text{ pF}$ ,  $t_{rCL} = t_{fCL} = 20\text{ ns}$ , unless otherwise specified

Symbol	Parameter	Conditions	Min	Typ	Max	Units
$t_{PHL}$ or $t_{PLH}$	Propagation Delay Time from Clock to Q or $\bar{Q}$	$V_{DD} = 5V$		200	400	ns
		$V_{DD} = 10V$		80	160	ns
		$V_{DD} = 15V$		65	130	ns
$t_{PHL}$ or $t_{PLH}$	Propagation Delay Time from Set to $\bar{Q}$ or Reset to Q	$V_{DD} = 5V$		170	340	ns
		$V_{DD} = 10V$		70	140	ns
		$V_{DD} = 15V$		55	110	ns
$t_{PHL}$ or $t_{PLH}$	Propagation Delay Time from Set to Q or Reset to $\bar{Q}$	$V_{DD} = 5V$		110	220	ns
		$V_{DD} = 10V$		50	100	ns
		$V_{DD} = 15V$		40	80	ns
$t_S$	Minimum Data Setup Time	$V_{DD} = 5V$		135	270	ns
		$V_{DD} = 10V$		55	110	ns
		$V_{DD} = 15V$		45	90	ns
$t_{THL}$ or $t_{TLH}$	Transition Time	$V_{DD} = 5V$		100	200	ns
		$V_{DD} = 10V$		50	100	ns
		$V_{DD} = 15V$		40	80	ns
$f_{CL}$	Maximum Clock Frequency (Toggle Mode)	$V_{DD} = 5V$	2.5	5		MHz
		$V_{DD} = 10V$	6.2	12.5		MHz
		$V_{DD} = 15V$	7.6	15.5		MHz
$t_{rCL}$ or $t_{fCL}$	Maximum Clock Rise and Fall Time	$V_{DD} = 5V$	15			$\mu\text{s}$
		$V_{DD} = 10V$	10			$\mu\text{s}$
		$V_{DD} = 15V$	5			$\mu\text{s}$
$t_W$	Minimum Clock Pulse Width ( $t_{WH} = t_{WL}$ )	$V_{DD} = 5V$		100	200	ns
		$V_{DD} = 10V$		40	80	ns
		$V_{DD} = 15V$		32	65	ns
$t_{WH}$	Minimum Set and Reset Pulse Width	$V_{DD} = 5V$		80	160	ns
		$V_{DD} = 10V$		30	60	ns
		$V_{DD} = 15V$		25	50	ns
$C_{IN}$	Average Input Capacitance	Any Input		5	7.5	pF
$C_{PD}$	Power Dissipation Capacity	Per Flip-Flop (Note 4)		35		pF

\*AC Parameters are guaranteed by DC correlated testing.

**Note 1:** "Absolute Maximum Ratings" are those values beyond which the safety of the device cannot be guaranteed. They are not meant to imply that the devices should be operated at these limits. The table of "Recommended Operating Conditions" and "Electrical Characteristics" provides conditions for actual device operation.

**Note 2:**  $V_{SS} = 0V$  unless otherwise specified.

**Note 3:**  $I_{OH}$  and  $I_{OL}$  are tested one output at a time.

**Note 4:**  $C_{PD}$  determines the no load AC power consumption of any CMOS device. For complete explanation, see 54C/74C Family Characteristics application note, AN-90.

## Typical Applications

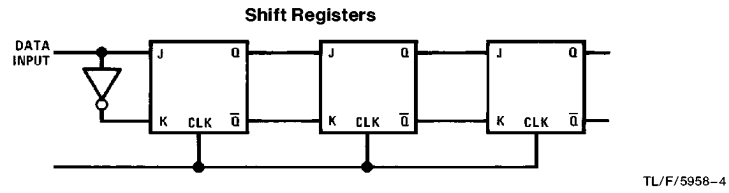
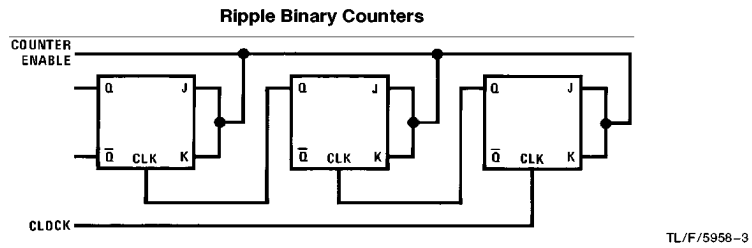

## Truth Table

CL <sup>▲</sup>	* <sub>t<sub>n-1</sub></sub> Inputs					■ <sub>t<sub>n</sub></sub> Outputs	
	J	K	S	R	Q	Q	$\bar{Q}$
—	1	X	0	0	0	1	0
—	X	0	0	0	1	1	0
—	0	X	0	0	0	0	1
—	X	1	0	0	1	0	1
—	X	X	0	0	X	(No Change)	
X	X	X	1	0	X	1	0
X	X	X	0	1	X	0	1
X	X	X	1	1	X	1	1

Where: 1 = High Level  
 0 = Low Level  
 ▲ = Level Change  
 X = Don't Care  
 \*<sub>t<sub>n-1</sub></sub> refers to the time interval prior to the positive clock pulse transition  
 ■<sub>t<sub>n</sub></sub> refers to the time intervals after the positive clock pulse transition

**Physical Dimensions** inches (millimeters)

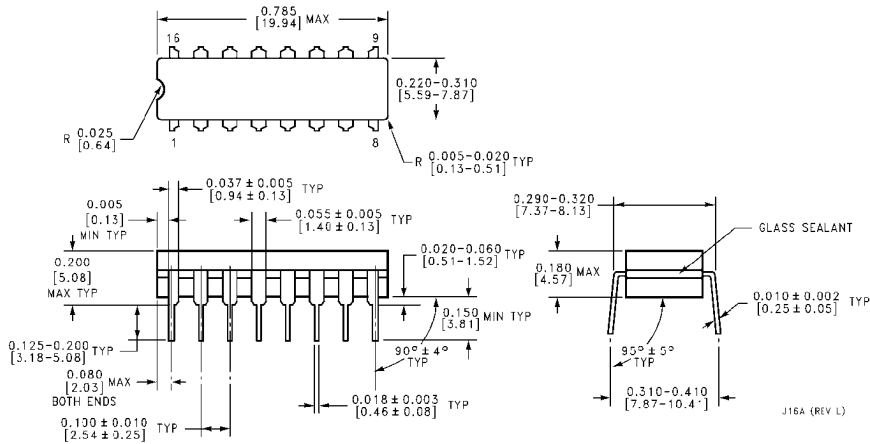

**Ceramic Dual-In-Line Package (J)**  
**Order Number CD4027BMJ or CD4027BCJ**  
**NS Package Number J16A**

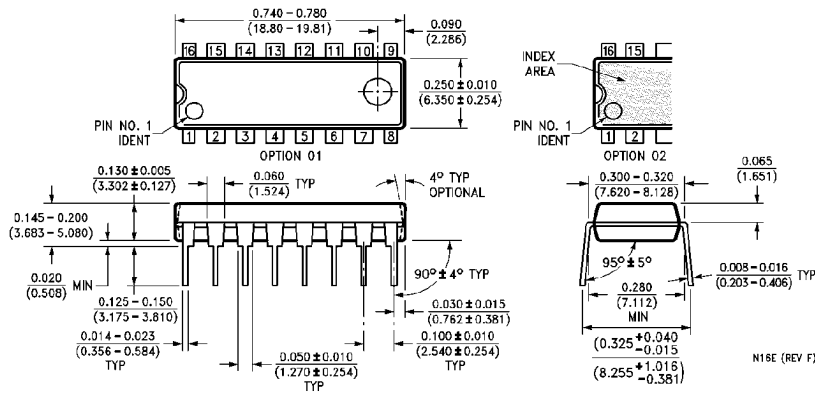

**Molded Dual-In-Line Package (N)**  
**Order Number CD4027BMN or CD4027BCN**  
**NS Package Number N16E**

**LIFE SUPPORT POLICY**

NATIONAL'S PRODUCTS ARE NOT AUTHORIZED FOR USE AS CRITICAL COMPONENTS IN LIFE SUPPORT DEVICES OR SYSTEMS WITHOUT THE EXPRESS WRITTEN APPROVAL OF THE PRESIDENT OF NATIONAL SEMICONDUCTOR CORPORATION. As used herein:

1. Life support devices or systems are devices or systems which, (a) are intended for surgical implant into the body, or (b) support or sustain life, and whose failure to perform, when properly used in accordance with instructions for use provided in the labeling, can be reasonably expected to result in a significant injury to the user.
2. A critical component is any component of a life support device or system whose failure to perform can be reasonably expected to cause the failure of the life support device or system, or to affect its safety or effectiveness.



**National Semiconductor Corporation**  
 1111 West Bardin Road  
 Arlington, TX 76017  
 Tel: 1(800) 272-9959  
 Fax: 1(800) 737-7018

**National Semiconductor Europe**  
 Fax: (+49) 0-180-530 85 86  
 Email: cnjwge@tevm2.nsc.com  
 Deutsch Tel: (+49) 0-180-530 85 85  
 English Tel: (+49) 0-180-532 78 32  
 Français Tel: (+49) 0-180-532 93 58  
 Italiano Tel: (+49) 0-180-534 16 80

**National Semiconductor Hong Kong Ltd.**  
 13th Floor, Straight Block,  
 Ocean Centre, 5 Canton Rd.  
 Tsimshatsui, Kowloon  
 Hong Kong  
 Tel: (852) 2737-1600  
 Fax: (852) 2736-9960

**National Semiconductor Japan Ltd.**  
 Tel: 81-043-299-2309  
 Fax: 81-043-299-2406

National does not assume any responsibility for use of any circuitry described, no circuit patent licenses are implied and National reserves the right at any time without notice to change said circuitry and specifications.