

## 54LS174/DM54LS174/DM74LS174, 54LS175/DM54LS175/DM74LS175 Hex/Quad D Flip-Flops with Clear

### General Description

These positive-edge-triggered flip-flops utilize TTL circuitry to implement D-type flip-flop logic. All have a direct clear input, and the quad (175) versions feature complementary outputs from each flip-flop.

Information at the D inputs meeting the setup time requirements is transferred to the Q outputs on the positive-going edge of the clock pulse. Clock triggering occurs at a particular voltage level and is not directly related to the transition time of the positive-going pulse. When the clock input is at either the high or low level, the D input signal has no effect at the output.

### Features

- LS174 contains six flip-flops with single-rail outputs
- LS175 contains four flip-flops with double-rail outputs
- Buffered clock and direct clear inputs
- Individual data input to each flip-flop
- Applications include:
  - Buffer/storage registers
  - Shift registers
  - Pattern generators
- Typical clock frequency 40 MHz
- Typical power dissipation per flip-flop 14 mW
- Alternate Military/Aerospace device (54LS174, 54LS175) is available. Contact a National Semiconductor Sales Office/Distributor for specifications.

### Connection Diagrams

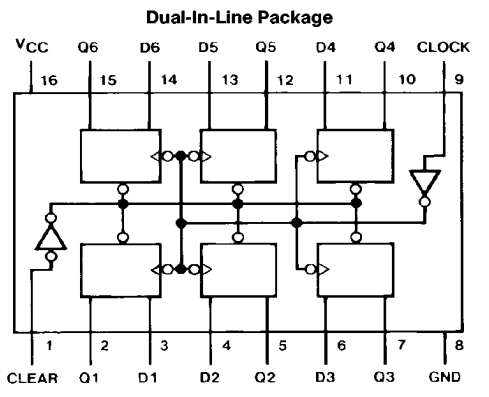

Order Number 54LS174DMQB, 54LS174FMQB,  
54LS174LMQB, DM54LS174J,  
DM54LS174W, DM74LS174M or DM74LS174N  
See NS Package Number E20A, J16A,  
M16A, N16E or W16A

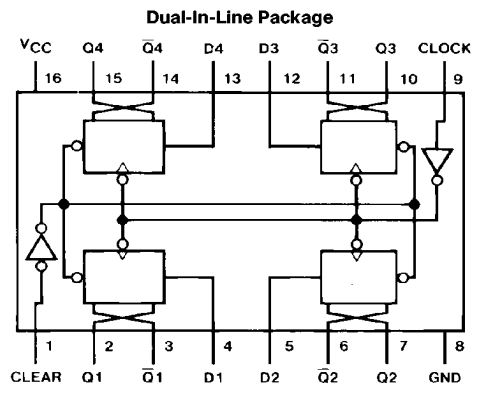

Order Number 54LS175DMQB, 54LS175FMQB,  
54LS175LMQB, DM54LS175J,  
DM54LS175W, DM74LS175M or DM74LS175N  
See NS Package Number E20A, J16A,  
M16A, N16E or W16A

### Function Table (Each Flip-Flop)

Inputs			Outputs	
Clear	Clock	D	Q	Q <sup>†</sup>
L	X	X	L	H
H	↑	H	H	L
H	↑	L	L	H
H	L	X	Q <sub>0</sub>	Q <sub>0</sub>

H = High Level (steady state)  
L = Low Level (steady state)  
X = Don't Care  
↑ = Transition from low to high level  
Q<sub>0</sub> = The level of Q before the indicated steady-state input conditions were established.  
† = LS175 only

54LS174/DM54LS174/DM74LS174, 54LS175/DM54LS175/DM74LS175  
Hex/Quad D Flip-Flops with Clear

## Absolute Maximum Ratings (Note)

If Military/Aerospace specified devices are required, please contact the National Semiconductor Sales Office/Distributors for availability and specifications.

Supply Voltage	7V
Input Voltage	7V
Operating Free Air Temperature Range	
DM54LS and 54LS	-55°C to +125°C
DM74LS	0°C to +70°C
Storage Temperature Range	-65°C to +150°C

Note: The "Absolute Maximum Ratings" are those values beyond which the safety of the device cannot be guaranteed. The device should not be operated at these limits. The parametric values defined in the "Electrical Characteristics" table are not guaranteed at the absolute maximum ratings. The "Recommended Operating Conditions" table will define the conditions for actual device operation.

## Recommended Operating Conditions

Symbol	Parameter	DM54LS174			DM74LS174			Units
		Min	Nom	Max	Min	Nom	Max	
V <sub>CC</sub>	Supply Voltage	4.5	5	5.5	4.75	5	5.25	V
V <sub>IH</sub>	High Level Input Voltage	2			2			V
V <sub>IL</sub>	Low Level Input Voltage			0.7			0.8	V
I <sub>OH</sub>	High Level Output Current			-0.4			-0.4	mA
I <sub>OL</sub>	Low Level Output Current			4			8	mA
f <sub>CLK</sub>	Clock Frequency (Note 1)	0		30	0		30	MHz
f <sub>CLK</sub>	Clock Frequency (Note 2)	0		25	0		25	MHz
t <sub>w</sub>	Pulse Width (Note 6)	Clock	20		20			ns
		Clear	20		20			
t <sub>SU</sub>	Data Setup Time (Note 6)	20			20			ns
t <sub>H</sub>	Data Hold Time (Note 6)	0			0			ns
t <sub>REL</sub>	Clear Release Time (Note 6)	25			25			ns
T <sub>A</sub>	Free Air Operating Temperature	-55		125	0		70	°C

## 'LS174 Electrical Characteristics

over recommended operating free air temperature range (unless otherwise noted)

Symbol	Parameter	Conditions	Min	Typ (Note 3)	Max	Units
V <sub>I</sub>	Input Clamp Voltage	V <sub>CC</sub> = Min, I <sub>I</sub> = -18 mA			-1.5	V
V <sub>OH</sub>	High Level Output Voltage	V <sub>CC</sub> = Min, I <sub>OH</sub> = Max V <sub>IL</sub> = Max, V <sub>IH</sub> = Min	DM54	2.5	3.4	V
			DM74	2.7	3.4	
V <sub>OL</sub>	Low Level Output Voltage	V <sub>CC</sub> = Min, I <sub>OL</sub> = Max V <sub>IL</sub> = Max, V <sub>IH</sub> = Min	DM54		0.25	V
			DM74		0.35	
			DM74	I <sub>OL</sub> = 4 mA, V <sub>CC</sub> = Min		
I <sub>I</sub>	Input Current@Max Input Voltage	V <sub>CC</sub> = Max, V <sub>I</sub> = 7V			0.1	mA
I <sub>IH</sub>	High Level Input Current	V <sub>CC</sub> = Max, V <sub>I</sub> = 2.7V			20	μA
I <sub>IL</sub>	Low Level Input Current	V <sub>CC</sub> = Max V <sub>I</sub> = 0.4V	Clock		-0.4	mA
			Clear		-0.4	
			Data		-0.36	
I <sub>OS</sub>	Short Circuit Output Current	V <sub>CC</sub> = Max (Note 4)	DM54	-20	-100	mA
			DM74	-20	-100	
I <sub>CC</sub>	Supply Current	V <sub>CC</sub> = Max (Note 5)		16	26	mA

Note 1: C<sub>L</sub> = 15 pF, R<sub>L</sub> = 2 kΩ, T<sub>A</sub> = 25°C and V<sub>CC</sub> = 5V.

Note 2: C<sub>L</sub> = 50 pF, R<sub>L</sub> = 2 kΩ, T<sub>A</sub> = 25°C and V<sub>CC</sub> = 5V.

Note 3: All typicals are at V<sub>CC</sub> = 5V, T<sub>A</sub> = 25°C.

Note 4: Not more than one output should be shorted at a time, and the duration should not exceed one second.

Note 5: With all outputs open and 4.5V applied to all data and clear inputs, I<sub>CC</sub> is measured after a momentary ground, then 4.5V applied to the clock.

Note 6: T<sub>A</sub> = 25°C and V<sub>CC</sub> = 5V.

## 'LS174 Switching Characteristics

at  $V_{CC} = 5V$  and  $T_A = 25^\circ C$  (See Section 1 for Test Waveforms and Output Load)

Symbol	Parameter	From (Input) To (Output)	$R_L = 2\text{ k}\Omega$				Units
			$C_L = 15\text{ pF}$		$C_L = 50\text{ pF}$		
			Min	Max	Min	Max	
$f_{MAX}$	Maximum Clock Frequency		30		25		MHz
$t_{PLH}$	Propagation Delay Time Low to High Level Output	Clock to Output		30		32	ns
$t_{PHL}$	Propagation Delay Time High to Low Level Output	Clock to Output		30		36	ns
$t_{PHL}$	Propagation Delay Time High to Low Level Output	Clear to Output		35		42	ns

## Recommended Operating Conditions

Symbol	Parameter	DM54LS175			DM74LS175			Units
		Min	Nom	Max	Min	Nom	Max	
$V_{CC}$	Supply Voltage	4.5	5	5.5	4.75	5	5.25	V
$V_{IH}$	High Level Input Voltage	2			2			V
$V_{IL}$	Low Level Input Voltage			0.7			0.8	V
$I_{OH}$	High Level Output Current			-0.4			-0.4	mA
$I_{OL}$	Low Level Output Current			4			8	mA
$f_{CLK}$	Clock Frequency (Note 1)	0		30	0		30	MHz
$f_{CLK}$	Clock Frequency (Note 2)	0		25	0		25	MHz
$t_w$	Pulse Width (Note 3)	Clock	20		20			ns
		Clear	20		20			
$t_{SU}$	Data Setup Time (Note 3)	20			20			ns
$t_H$	Data Hold Time (Note 3)	0			0			ns
$t_{REL}$	Clear Release Time (Note 3)	25			25			ns
$T_A$	Free Air Operating Temperature	-55		125	0		70	$^\circ C$

**Note 1:**  $C_L = 15\text{ pF}$ ,  $R_L = 2\text{ k}\Omega$ ,  $T_A = 25^\circ C$  and  $V_{CC} = 5V$ .

**Note 2:**  $C_L = 50\text{ pF}$ ,  $R_L = 2\text{ k}\Omega$ ,  $T_A = 25^\circ C$  and  $V_{CC} = 5V$ .

**Note 3:**  $T_A = 25^\circ C$  and  $V_{CC} = 5V$ .

## 'LS175 Electrical Characteristics

over recommended operating free air temperature range (unless otherwise noted)

Symbol	Parameter	Conditions	Min	Typ (Note 1)	Max	Units
$V_I$	Input Clamp Voltage	$V_{CC} = \text{Min}, I_I = -18 \text{ mA}$			-1.5	V
$V_{OH}$	High Level Output Voltage	$V_{CC} = \text{Min}, I_{OH} = \text{Max}$ $V_{IL} = \text{Max}, V_{IH} = \text{Min}$	DM54 DM74	2.5 2.7	3.4 3.4	V
$V_{OL}$	Low Level Output Voltage	$V_{CC} = \text{Min}, I_{OL} = \text{Max}$ $V_{IL} = \text{Max}, V_{IH} = \text{Min}$ $I_{OL} = 4 \text{ mA}, V_{CC} = \text{Min}$	DM54 DM74 DM74		0.25 0.35 0.25	0.4 0.5 0.4
$I_I$	Input Current@Max Input Voltage	$V_{CC} = \text{Max}, V_I = 7V$			0.1	mA
$I_{IH}$	High Level Input Current	$V_{CC} = \text{Max}, V_I = 2.7V$			20	$\mu\text{A}$
$I_{IL}$	Low Level Input Current	$V_{CC} = \text{Max}$ $V_I = 0.4V$	Clock Clear Data		-0.4 -0.4 -0.36	mA
$I_{OS}$	Short Circuit Output Current	$V_{CC} = \text{Max}$ (Note 2)	DM54 DM74	-20 -20	-100 -100	mA
$I_{CC}$	Supply Current	$V_{CC} = \text{Max}$ (Note 3)		11	18	mA

## 'LS175 Switching Characteristics

at  $V_{CC} = 5V$  and  $T_A = 25^\circ\text{C}$  (See Section 1 for Test Waveforms and Output Load)

Symbol	Parameter	From (Input) To (Output)	$R_L = 2 \text{ k}\Omega$				Units
			$C_L = 15 \text{ pF}$		$C_L = 50 \text{ pF}$		
			Min	Max	Min	Max	
$f_{MAX}$	Maximum Clock Frequency		30		25		MHz
$t_{PLH}$	Propagation Delay Time Low to High Level Output	Clock to Q or $\bar{Q}$		30		32	ns
$t_{PHL}$	Propagation Delay Time High to Low Level Output	Clock to Q or $\bar{Q}$		30		36	ns
$t_{PLH}$	Propagation Delay Time Low to High Level Output	Clear to $\bar{Q}$		25		29	ns
$t_{PHL}$	Propagation Delay Time High to Low Level Output	Clear to Q		35		42	ns

**Note 1:** All typicals are at  $V_{CC} = 5V, T_A = 25^\circ\text{C}$ .

**Note 2:** Not more than one output should be shorted at a time, and the duration should not exceed one second.

**Note 3:** With all outputs open and 4.5V applied to all data and clear inputs,  $I_{CC}$  is measured after a momentary ground, then 4.5V applied to the clock input.

# Logic Diagrams

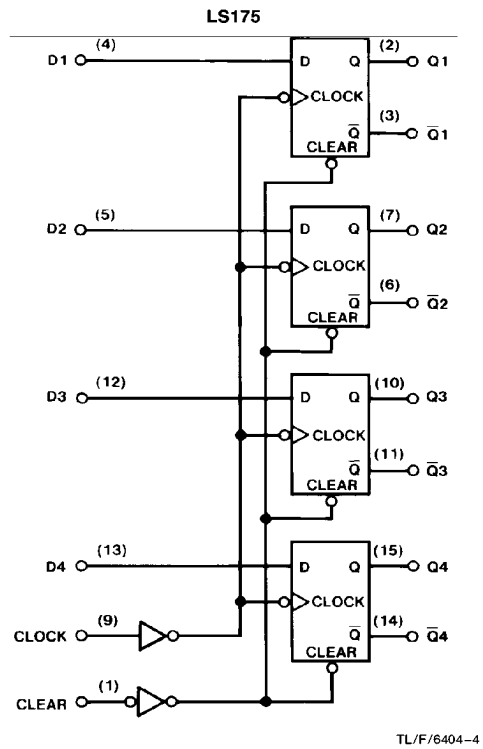
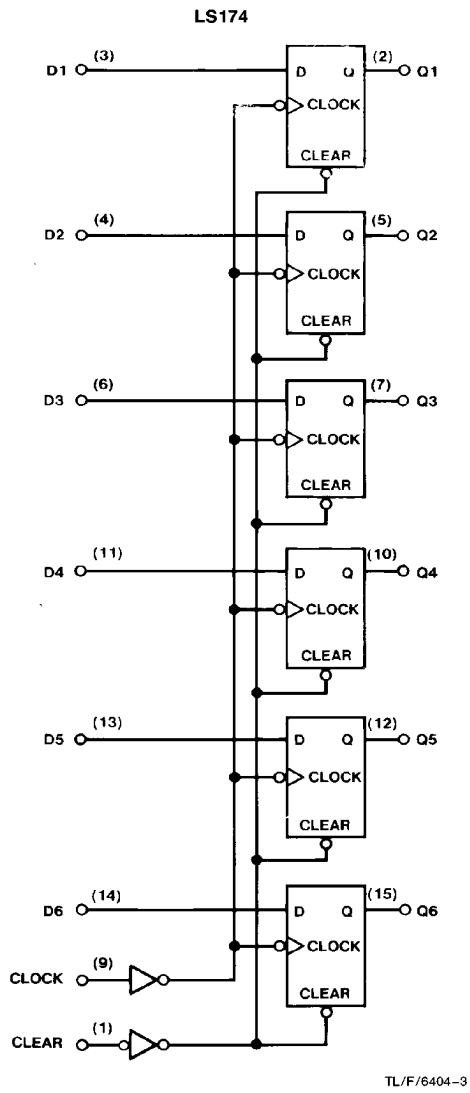

**Physical Dimensions** inches (millimeters)

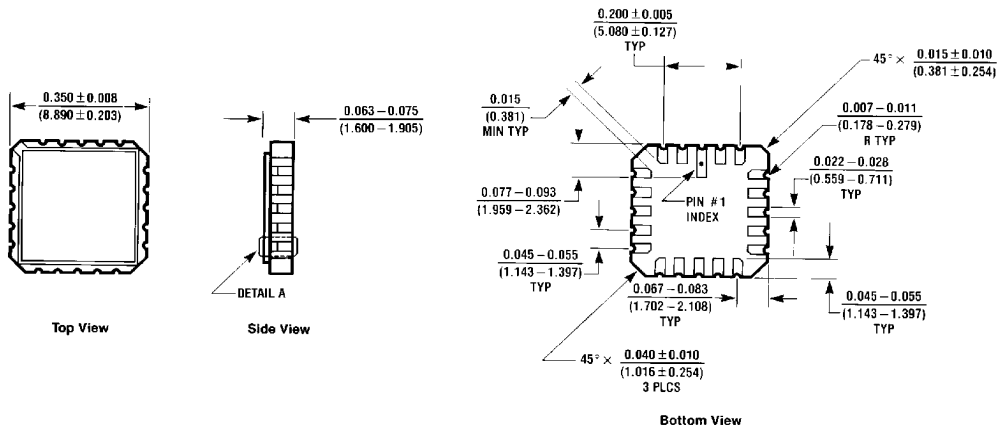

E20A (REV D)

**Ceramic Leadless Chip Carrier (E)**  
**Order Number 54LS174LMQB or 54LS175LMQB**  
**NS Package Number E20A**

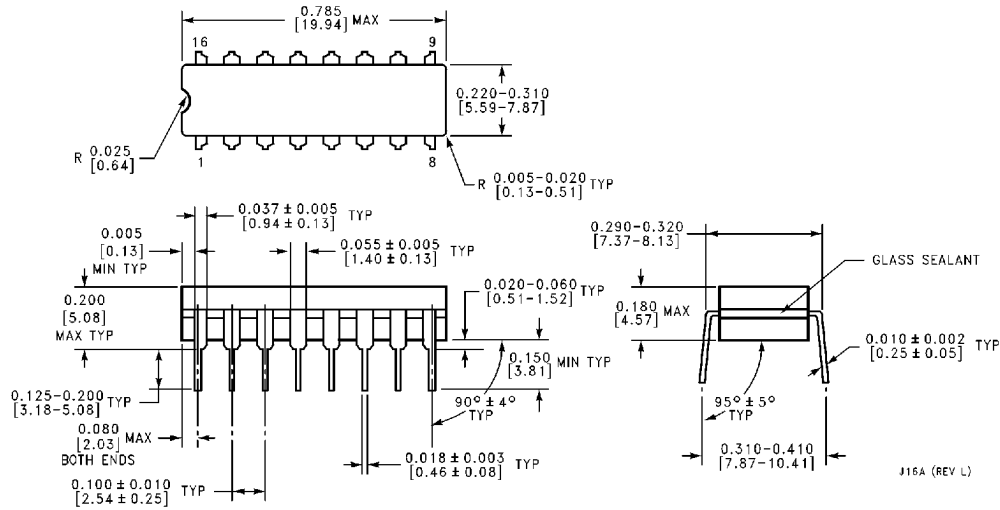

J16A (REV L)

**16-Lead Ceramic Dual-In-Line Package (J)**  
**Order Number DM54LS174DMQB, 54LS175DMQB, DM54LS174J or DM54LS175J**  
**NS Package Number J16A**

**Physical Dimensions** inches (millimeters) (Continued)

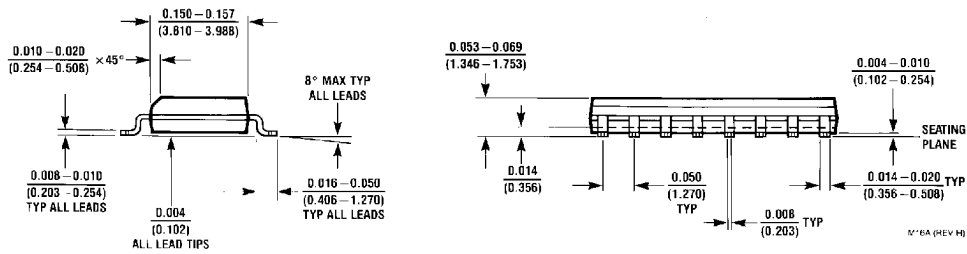
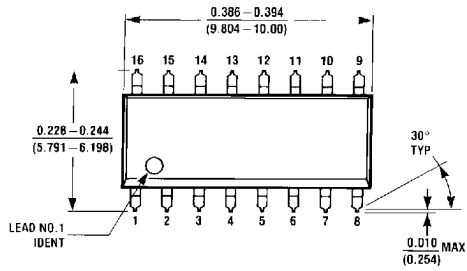

**16-Lead Small Outline Molded Package (M)**  
**Order Number DM74LS174M or DM74LS175M**  
**NS Package Number M16A**

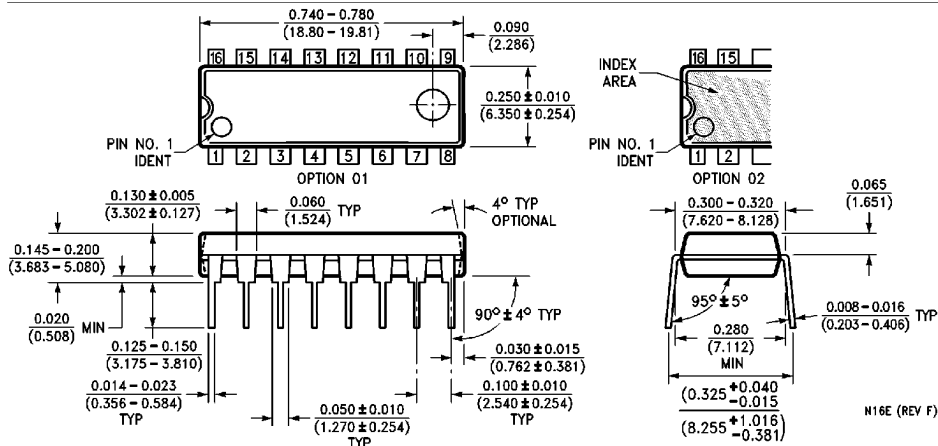

**16-Lead Molded Dual-In-Line Package (N)**  
**Order Number DM74LS174N or DM74LS175N**  
**NS Package Number N16E**

54LS174/DM54LS174/DM74LS174, 54LS175/DM54LS175/DM74LS175 Hex/Quad D Flip-Flops with Clear

**Physical Dimensions** inches (millimeters) (Continued)

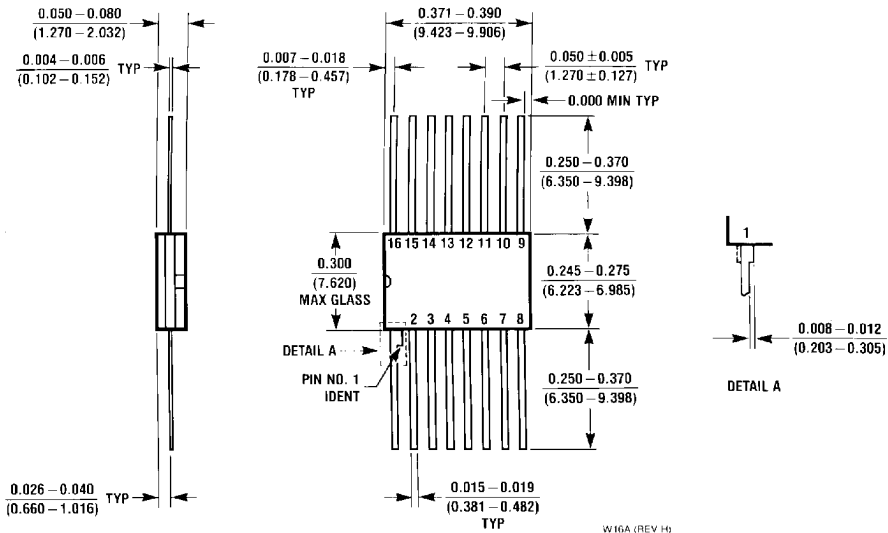

**16-Lead Ceramic Flat Package (W)**  
**Order Number 54LS174FMQB, 54LS175FMQB, DM54LS174W or DM54LS175W**  
**NS Package Number W16A**

**LIFE SUPPORT POLICY**

NATIONAL'S PRODUCTS ARE NOT AUTHORIZED FOR USE AS CRITICAL COMPONENTS IN LIFE SUPPORT DEVICES OR SYSTEMS WITHOUT THE EXPRESS WRITTEN APPROVAL OF THE PRESIDENT OF NATIONAL SEMICONDUCTOR CORPORATION. As used herein:

1. Life support devices or systems are devices or systems which, (a) are intended for surgical implant into the body, or (b) support or sustain life, and whose failure to perform, when properly used in accordance with instructions for use provided in the labeling, can be reasonably expected to result in a significant injury to the user.
2. A critical component is any component of a life support device or system whose failure to perform can be reasonably expected to cause the failure of the life support device or system, or to affect its safety or effectiveness.



**National Semiconductor Corporation**  
 1111 West Bardin Road  
 Arlington, TX 76017  
 Tel: 1(800) 272-9959  
 Fax: 1(800) 737-7018

**National Semiconductor Europe**  
 Fax: (+49) 0-180-530 85 86  
 Email: cnjwge@tevm2.nsc.com  
 Deutsch Tel: (+49) 0-180-530 85 85  
 English Tel: (+49) 0-180-532 78 32  
 Français Tel: (+49) 0-180-532 93 58  
 Italiano Tel: (+49) 0-180-534 16 80

**National Semiconductor Hong Kong Ltd.**  
 13th Floor, Straight Block,  
 Ocean Centre, 5 Canton Rd.  
 Tsimshatsui, Kowloon  
 Hong Kong  
 Tel: (852) 2737-1600  
 Fax: (852) 2736-9960

**National Semiconductor Japan Ltd.**  
 Tel: 81-043-299-2309  
 Fax: 81-043-299-2406

National does not assume any responsibility for use of any circuitry described, no circuit patent licenses are implied and National reserves the right at any time without notice to change said circuitry and specifications.