

COS/MOS INTEGRATED CIRCUITS

4000B
4001B
4002B
4025B



NOR GATES: DUAL 3 INPUT PLUS INVERTER HCC/HCF 4000B
QUAD 2 INPUT HCC/HCF 4001B
DUAL 4 INPUT HCC/HCF 4002B
TRIPLE 3 INPUT HCC/HCF 4025B

- PROPAGATION DELAY TIME = 60 ns (TYP.) AT $C_L = 50$ pF, $V_{DD} = 10$ V
- BUFFERED INPUTS AND OUTPUTS
- STANDARDIZED SYMMETRICAL OUTPUT CHARACTERISTICS
- QUIESCENT CURRENT SPECIFIED TO 20V FOR HCC DEVICE
- 5V, 10V, AND 15V PARAMETRIC RATINGS
- INPUT CURRENT OF 100 nA AT 18V AND 25°C FOR HCC DEVICE
- 100% TESTED FOR QUIESCENT CURRENT
- MEETS ALL REQUIREMENTS OF JEDEC TENTATIVE STANDARD NO. 13A, "STANDARD SPECIFICATIONS FOR DESCRIPTION OF "B" SERIES CMOS DEVICES"

The **HCC 4000B**, **HCC 4001B**, **HCC 4002B** and **HCC 4025B** (extended temperature range) and **HCF 4000B**, **HCF 4001B**, **HCF 4002B** and **HCF 4025B** (intermediate temperature range) are monolithic integrated circuit, available in 14-lead dual in-line plastic or ceramic package, ceramic flat package and plastic micropackage.

The **HCC/HCF 4000B**, **HCC/HCF 4001B**, **HCC/HCF 4002B** and **HCC/HCF 4025B** NOR gates provide the system designer with direct implementation of the NOR function and supplement the existing family of CMOS/MOS gates. All inputs and outputs are buffered.

ABSOLUTE MAXIMUM RATINGS

R7

V_{DD}^*	Supply voltage: HCC types HCF types	-0.5 to 20 V -0.5 to 18 V
V_i	Input voltage	-0.5 to $V_{DD} + 0.5$ V
I_i	DC input current (any one input)	± 10 mA
P_{tot}	Total power dissipation (per package) Dissipation per output transistor for Top - full package temperature range	200 mW 100 mW
T_{op}	Operating temperature: HCC types HCF types	-55 to 125 °C -40 to 85 °C
T_{stg}	Storage temperature	-65 to 150 °C

* All voltage values are referred to V_{SS} pin voltage

ORDERING NUMBERS:

HCC 4XXX BD for dual in-line ceramic package
HCC 4XXX BF for dual in-line ceramic package, frit seal
HCC 4XXX BK for ceramic flat package
HCF 4XXX BE for dual in-line plastic package
HCF 4XXX BF for dual in-line ceramic package, frit seal
HCF 4XXX BM for plastic micropackage



MECHANICAL DATA (dimensions in mm)

Dual in-line ceramic package for HCC 4XXX BD

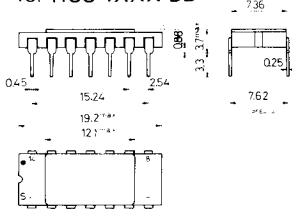

Dual in-line ceramic package for HCC/HCF 4XXX BF

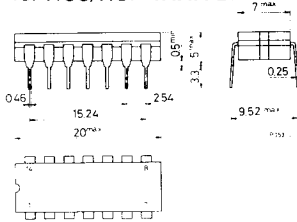

Dual in-line plastic package for HCF 4XXX BE

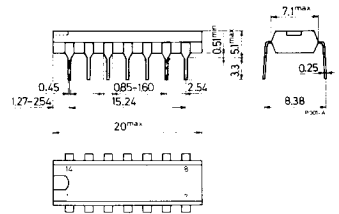

Ceramic flat package for HCC 4XXX BK

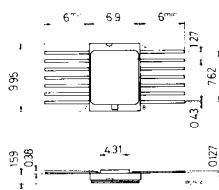

Plastic micropackage for HCF 4XXX BM

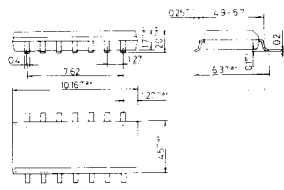

CONNECTION DIAGRAMS

for 4000B

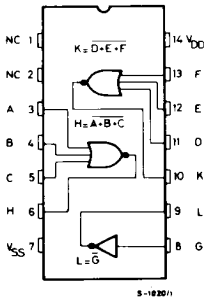

for 4001B

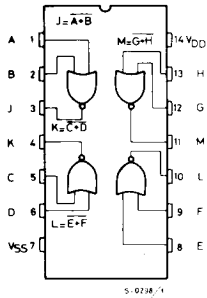

for 4002B

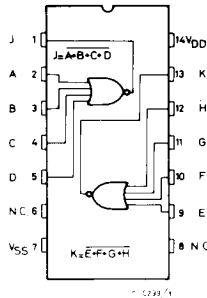

for 4025B

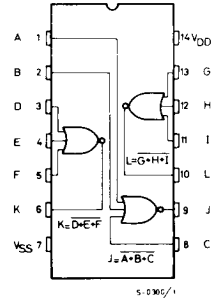

RECOMMENDED OPERATING CONDITIONS

V_{DD}	Supply voltage: HCC types HCF types	3 to 18 V 3 to 15 V
V_i	Input voltage	0 to V_{DD} V
T_{op}	Operating temperature: HCC types HCF types	-55 to 125 °C -40 to 85 °C

SCHEMATIC AND LOGIC DIAGRAMS

for **4000B**

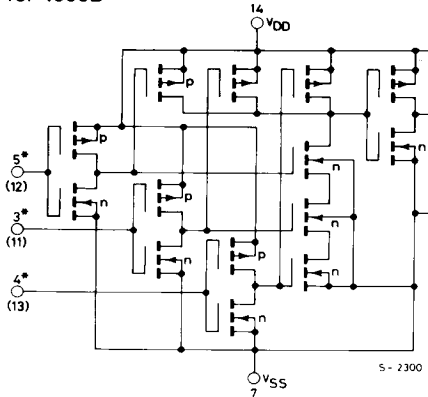

INVERTER AND 1 OF 2 GATES (NUMBERS IN PARENTHESES ARE TERMINAL NUMBERS FOR SECOND GATE)

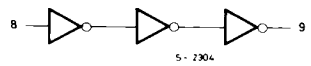
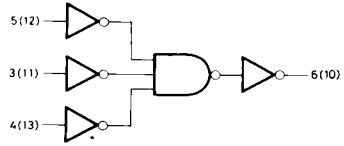
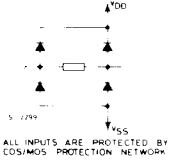

for **4001B**

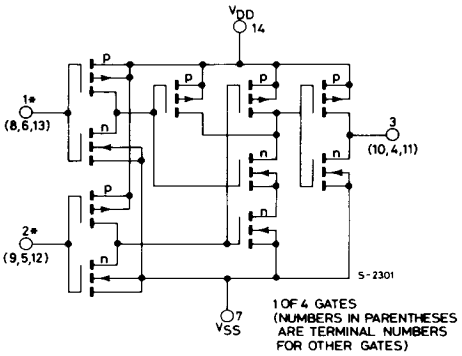

1 OF 4 GATES (NUMBERS IN PARENTHESES ARE TERMINAL NUMBERS FOR OTHER GATES)

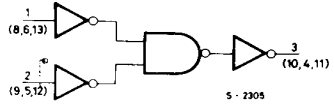
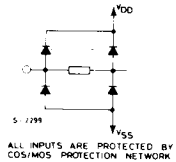

SCHEMATIC AND LOGIC DIAGRAMS (continued)

for 4002B

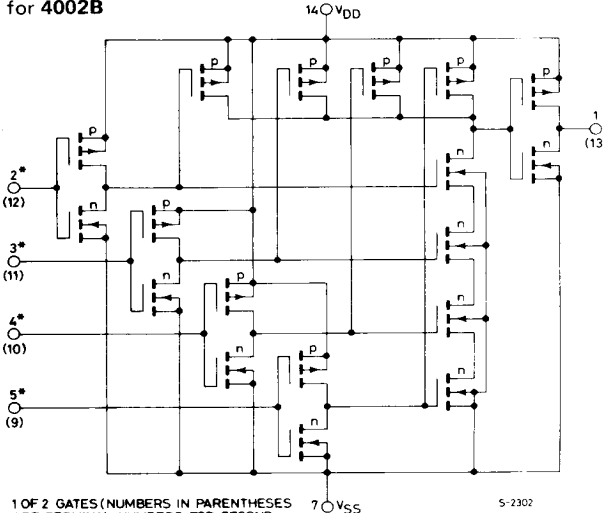

1 OF 2 GATES (NUMBERS IN PARENTHESES ARE TERMINAL NUMBERS FOR SECOND GATE)

5-2302

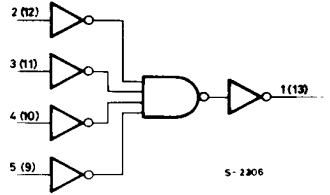

5-2306

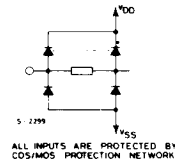

ALL INPUTS ARE PROTECTED BY COS/MOS PROTECTION NETWORK

for 4025B

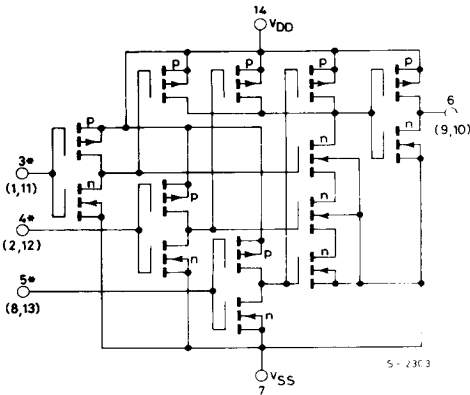

INVERTER AND 1 OF 3 GATES (NUMBERS IN PARENTHESES ARE TERMINAL NUMBERS FOR SECOND GATE)

5-2303

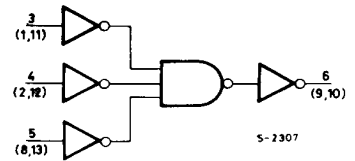

5-2307

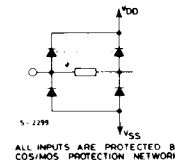

ALL INPUTS ARE PROTECTED BY COS/MOS PROTECTION NETWORK

400-260
400-300

COMPL



STATIC ELECTRICAL CHARACTERISTICS (over recommended operating conditions)

Parameter		Test conditions				Values						Unit		
		V _I (V)	V _O (V)	I _O (μ A)	V _{DD} (V)	T _{Low} *		T _{amb} = 25°C			T _{High} *			
						Min.	Max.	Min.	Typ.	Max.	Min.		Max.	
I _L	Quiescent current	HCC types	0/ 5			5		0.25		0.01	0.25		7.5	μ A
			0/10			10		0.5		0.01	0.5		15	
			0/15			15		1		0.01	1		30	
			0/20			20		5		0.02	5		150	
	HCF types	0/ 5			5		1		0.01	1		7.5		
		0/10			10		2		0.01	2		15		
	0/15			15		4		0.01	4		30			
V _{OH}	Output high voltage	0/ 5		< 1	5	4.95		4.95			4.95		V	
		0/10		< 1	10	9.95		9.95			9.95			
		0/15		< 1	15	14.95		14.95			14.95			
V _{OL}	Output low voltage	5/0		< 1	5		0.05			0.05		0.05	V	
		10/0		< 1	10		0.05			0.05		0.05		
		15/0		< 1	15		0.05			0.05		0.05		
V _{IH}	Input high voltage		0.5/4.5	< 1	5	3.5		3.5			3.5		V	
			1/9	< 1	10	7		7			7			
			1.5/13.5	< 1	15	11		11			11			
V _{IL}	Input low voltage		4.5/0.5	< 1	5		1.5			1.5		1.5	V	
			9/1	< 1	10		3			3		3		
			13.5/1.5	< 1	15		4			4		4		
I _{OH}	Output drive current	HCC types	0/ 5	2.5		5	-2		-1.6	-3.2		-1.15	mA	
			0/ 5	4.6		5	-0.64		-0.51	-1		-0.36		
			0/10	9.5		10	-1.6		-1.3	-2.6		-0.9		
		0/15	13.5		15	-4.2		-3.4	-6.8		-2.4			
		HCF types	0/ 5	2.5		5	-1.53		-1.36	-3.2		-1.1		
			0/ 5	4.6		5	-0.52		-0.44	-1		-0.36		
0/10	9.5			10	-1.3		-1.1	-2.6		-0.9				
	0/15	13.5		15	-3.6		-3.0	-6.8		-2.4				
I _{OL}	Output sink current	HCC types	0/ 5	0.4		5	0.64		0.51	1		0.36	mA	
			0/10	0.5		10	1.6		1.3	2.6		0.9		
			0/15	1.5		15	4.2		3.4	6.8		2.4		
		HCF types	0/ 5	0.4		5	0.52		0.44	1		0.36		
			0/10	0.5		10	1.3		1.1	2.6		0.9		
			0/15	1.5		15	3.6		3.0	6.8		2.4		
I _{IH} , I _{IL}	Input leakage current	HCC types	0/18	Any input	18		\pm 0.1		\pm 10 ⁻⁵	\pm 0.1		\pm 1	μ A	
		HCF types	0/15		15		\pm 0.3		\pm 10 ⁻⁵	\pm 0.3		\pm 1		
C _I	Input capacitance		Any input						5	7.5		pF		

* T_{Low} = - 55°C for HCC device; -40°C for HCF device.
 * T_{High} = +125°C for HCC device; +85°C for HCF device.
 The Noise Margin for both "1" and "0" level is: 1V min. with V_{DD} = 5V
 2V min. with V_{DD} = 10V
 2.5V min. with V_{DD} = 15V

DYNAMIC ELECTRICAL CHARACTERISTICS ($T_{amb} = 25^{\circ}\text{C}$, $C_L = 50\text{ pF}$, $R_L = 200\text{ k}\Omega$, typical temperature coefficient for all V_{DD} values is 0,3%/ $^{\circ}\text{C}$, all input rise and fall times = 20 ns)

Parameter	Test conditions	Values			Unit	
		V_{DD} (V)	Min.	Typ.		Max.
t_{PHL} , t_{PLH} Propagation delay time		5		125	250	ns
		10		60	120	
		15		45	90	
t_{THL} , t_{TLH} Transition time		5		100	200	ns
		10		50	100	
		15		40	80	

Typical output low (sink) current characteristics

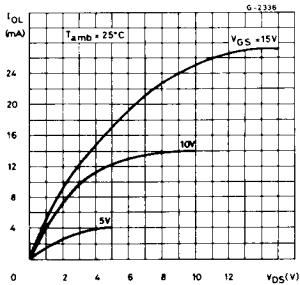

Minimum output low (sink) current characteristics

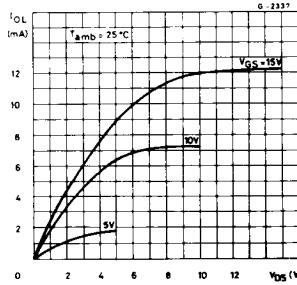

Typical output high (source) current characteristics

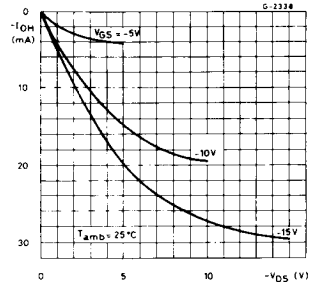

Minimum output high (source) current characteristics

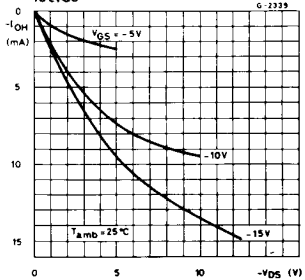

Typical transition time vs. load capacitance

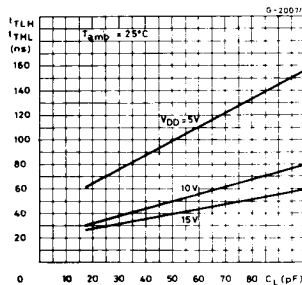

Typical propagation delay time vs. load capacitance

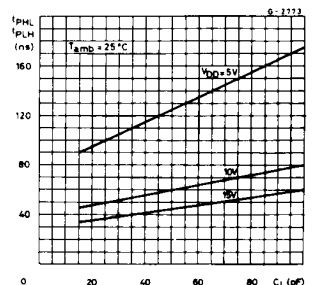

Typical voltage transfer characteristics as a function of temperature

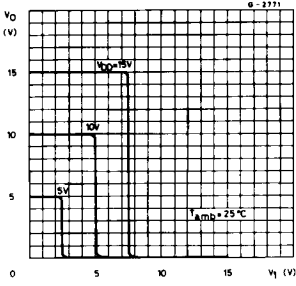

Typical power dissipation per gate vs. frequency

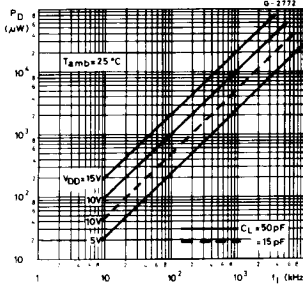

TEST CIRCUITS

Quiescent device current

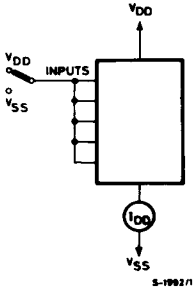

Input voltage

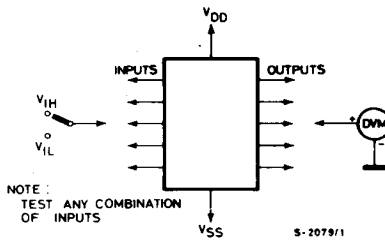

Input leakage current

