

## MM54HCT05/MM74HCT05 Hex Inverter (Open Drain)

### General Description

The MM54HCT05/MM74HCT05 are logic functions fabricated by using advanced silicon-gate CMOS technology, which provides the inherent benefits of CMOS—low quiescent power and wide power supply range. These devices are also input and output characteristic and pinout compatible with standard DM54LS/DM74LS logic families. The MM54HCT05/MM74HCT05 open drain Hex Inverter requires the addition of an external resistor to perform a wire-NOR function.

All inputs are protected from static discharge damage by internal diodes to  $V_{CC}$  and ground.

MM54HCT/MM74HCT devices are intended to interface between TTL and NMOS components and standard CMOS devices. These parts are also plug-in replacements for LS-TTL devices and can be used to reduce power consumption in existing designs.

### Features

- Open drain for wire-NOR function
- LS-TTL pinout and threshold compatible
- Fanout of 10 LS-TTL loads
- Typical propagation delays:
  - $t_{PLH}$  (with 1 k $\Omega$  resistor) 10 ns
  - $t_{PHL}$  (with 1 k $\Omega$  resistor) 8 ns

### Connection Diagram

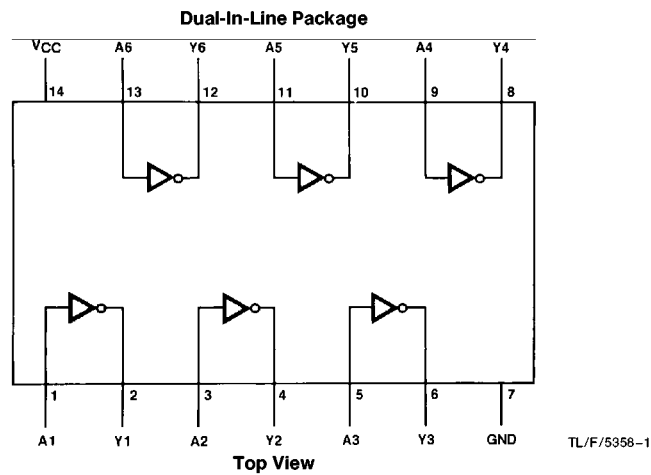

Order Number MM54HCT05 or MM74HCT05

### Logic Diagram

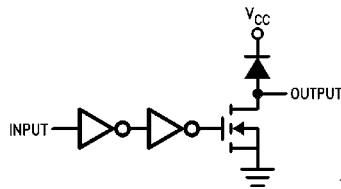

### Typical Application

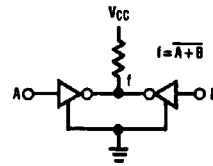

Note: Can be extended to more than 2 inputs.

### Absolute Maximum Ratings (Notes 1 & 2)

If Military/Aerospace specified devices are required, please contact the National Semiconductor Sales Office/Distributors for availability and specifications.

Supply Voltage ( $V_{CC}$ )	-0.5 to +7.0V
DC Input Voltage ( $V_{IN}$ )	-1.5 to $V_{CC} + 1.5V$
DC Output Voltage ( $V_{OUT}$ )	-0.5 to $V_{CC} + 0.5V$
Clamp Diode Current ( $I_{IK}, I_{OK}$ )	$\pm 20$ mA
DC Output Current, per pin ( $I_{OUT}$ )	$\pm 25$ mA
DC $V_{CC}$ or GND Current, per pin ( $I_{CC}$ )	$\pm 50$ mA
Storage Temperature Range ( $T_{STG}$ )	-65°C to +150°C
Power Dissipation ( $P_D$ )	
(Note 3)	600 mW
S.O. Package only	500 mW
Lead Temperature ( $T_L$ )	
(Soldering 10 seconds)	260°C

### Operating Conditions

	Min	Max	Units
Supply Voltage ( $V_{CC}$ )	4.5	5.5	V
DC Input or Output Voltage ( $V_{IN}, V_{OUT}$ )	0	$V_{CC}$	V
Operating Temp. Range ( $T_A$ )			
MM74HCT	-40	+85	°C
MM54HCT	-55	+125	°C
Input Rise or Fall Times ( $t_r, t_f$ )		500	ns

### DC Electrical Characteristics ( $V_{CC} = 5V \pm 10\%$ , unless otherwise specified)

Symbol	Parameter	Conditions	$T_A = 25^\circ C$		74HCT	54HCT	Units
			Typ	Guaranteed Limits			
				$T_A = -40$ to $85^\circ C$	$T_A = -55$ to $125^\circ C$		
$V_{IH}$	Minimum High Level Input Voltage			2.0	2.0	2.0	V
$V_{IL}$	Maximum Low Level Input Voltage			0.8	0.8	0.8	V
$V_{OL}$	Maximum Low Level Voltage	$V_{IN} = V_{IH}$ $ I_{OUT}  = 20 \mu A$ $ I_{OUT}  = 4.0$ mA, $V_{CC} = 4.5V$ $ I_{OUT}  = 4.8$ mA, $V_{CC} = 5.5V$	0	0.1	0.1	0.1	V
			0.2	0.26	0.33	0.4	V
			0.2	0.26	0.33	0.4	V
$I_{IN}$	Maximum Input Current	$V_{IN} = V_{CC}$ or GND, $V_{IH}$ or $V_{IL}$		$\pm 0.1$	$\pm 1.0$	$\pm 1.0$	$\mu A$
$I_{LKG}$	Minimum High Level Output Leakage Current	$V_{IN} = V_{IH}$ or $V_{IL}$ , $V_{OUT} = V_{CC}$		0.5	5.0	10	$\mu A$
$I_{CC}$	Maximum Quiescent Supply Current	$V_{IN} = V_{CC}$ or GND $I_{OUT} = 0 \mu A$		2.0	20	40	$\mu A$
				0.3	0.4	0.5	mA
		$V_{IN} = 2.4V$ or $0.5V$ (Note 4)					

**Note 1:** Absolute Maximum Ratings are those values beyond which damage to the device may occur.

**Note 2:** Unless otherwise specified all voltages are referenced to ground.

**Note 3:** Power Dissipation temperature derating — plastic "N" package: -12 mW/°C from 65°C to 85°C; ceramic "J" package: -12 mW/°C from 100°C to 125°C.

**Note 4:** This is measured per input with all other inputs held at  $V_{CC}$  or ground.

**AC Electrical Characteristics**  $V_{CC}=5V$ ,  $T_A=25^\circ C$ ,  $C_L=15\text{ pF}$ ,  $t_r=t_f=6\text{ ns}$  unless otherwise noted.

Symbol	Parameter	Conditions	Typ	Guaranteed Limit	Units
$t_{PZL}$	Maximum Propagation Delay	$R_L=1\text{ k}\Omega$	8	15	ns
$t_{PLZ}$	Maximum Propagation Delay	$R_L=1\text{ k}\Omega$	9	16	ns

**AC Electrical Characteristics**  $V_{CC}=5V \pm 10\%$ ,  $C_L=50\text{ pF}$ ,  $t_r=t_f=6\text{ ns}$  unless otherwise specified

Symbol	Parameter	Conditions	$T_A=25^\circ C$		74HCT	54HCT	Units
			Typ	Guaranteed Limits		$T_A=-40\text{ to }85^\circ C$	
$t_{PZL}$	Maximum Propagation Delay	$R_L=1\text{ k}\Omega$	10	22	28	33	ns
$t_{PLZ}$	Maximum Propagation Delay	$R_L=1\text{ k}\Omega$	12	20	25	30	ns
$t_{THL}$	Maximum Output Fall Time		10	15	19	22	ns
$C_{PD}$	Power Dissipation Capacitance (Note 5)	(per gate) $R_L=\infty$		20			pF
$C_{IN}$	Maximum Input Capacitance			5	10	10	pF

**Note 5:**  $C_{PD}$  determines the no load dynamic power consumption,  $P_D=C_{PD} V_{CC}^2 f + I_{CC} V_{CC}$ , and the no load dynamic current consumption,  $I_S=C_{PD} V_{CC} f + I_{CC}$ .

**Physical Dimensions** inches (millimeters)

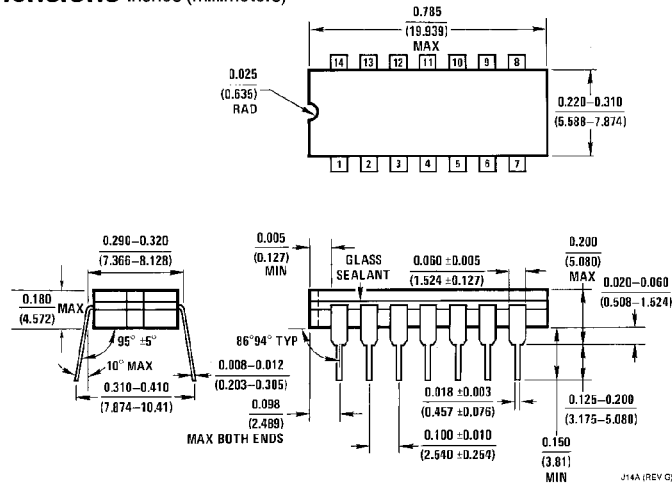

**Ceramic Dual-In-Line Package (J)**  
**Order Number MM54HCT05J**  
 See NS Package J14A

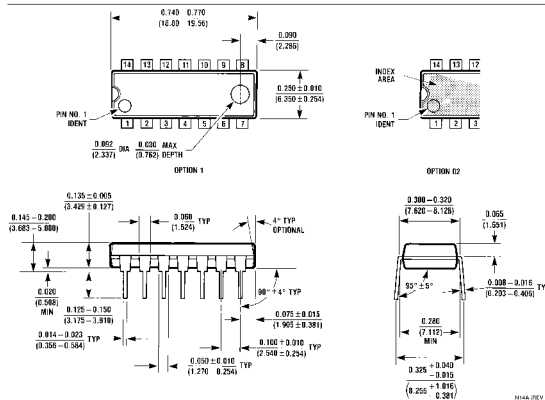

**Molded Dual-In-Line Package (N)**  
**Order Number MM74HCT05J, N**  
 See NS Package N14A

**LIFE SUPPORT POLICY**

NATIONAL'S PRODUCTS ARE NOT AUTHORIZED FOR USE AS CRITICAL COMPONENTS IN LIFE SUPPORT DEVICES OR SYSTEMS WITHOUT THE EXPRESS WRITTEN APPROVAL OF THE PRESIDENT OF NATIONAL SEMICONDUCTOR CORPORATION. As used herein:

1. Life support devices or systems are devices or systems which, (a) are intended for surgical implant into the body, or (b) support or sustain life, and whose failure to perform, when properly used in accordance with instructions for use provided in the labeling, can be reasonably expected to result in a significant injury to the user.
2. A critical component is any component of a life support device or system whose failure to perform can be reasonably expected to cause the failure of the life support device or system, or to affect its safety or effectiveness.



**National Semiconductor Corporation**  
 1111 West Bardin Road  
 Arlington, TX 76017  
 Tel: 1(800) 272-9959  
 Fax: 1(800) 737-7018

**National Semiconductor Europe**  
 Fax: (+49) 0-180-530 85 86  
 Email: cnjwge@tevm2.nsc.com  
 Deutsch Tel: (+49) 0-180-530 85 85  
 English Tel: (+49) 0-180-532 78 32  
 Français Tel: (+49) 0-180-532 93 58  
 Italiano Tel: (+49) 0-180-534 16 80

**National Semiconductor Hong Kong Ltd.**  
 13th Floor, Straight Block,  
 Ocean Centre, 5 Canton Rd.  
 Tsimshatsui, Kowloon  
 Hong Kong  
 Tel: (852) 2737-1600  
 Fax: (852) 2736-9960

**National Semiconductor Japan Ltd.**  
 Tel: 81-043-299-2309  
 Fax: 81-043-299-2408

National does not assume any responsibility for use of any circuitry described, no circuit patent licenses are implied and National reserves the right at any time without notice to change said circuitry and specifications.