

# TA7288P

## DUAL BRIDGE DRIVER

The TA7288P is a bridge driver that is ideal for normal / reverse switching.

This circuit offers four modes : normal rotation, reverse rotation, stop, and brake.

The output current is 1.0A (AVE.) and 2.0A (PEAK).

TA7288P has an ideal circuit configuration for VCR front tape loading and offers two types of power supply pins.

One is for output, the other for control. The  $V_{ref}$  pin on the output side used to control the motor voltage facilitates motor voltage adjustment. The IC requires little input current, enabling direct connection with CMOS.

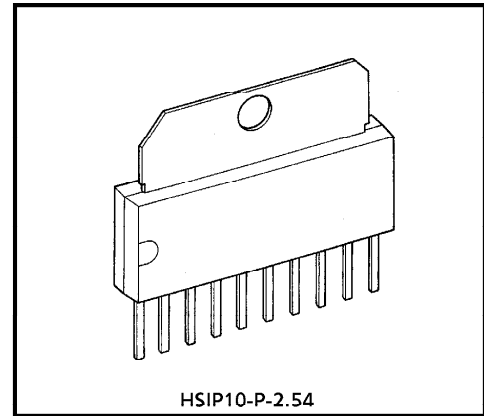

Weight : 2.47g (Typ.)

### FEATURES

- 4 Modes Available (CW / CCW / STOP / BRAKE)
- Output Current Up to 1.0A (AVE.) and 2.0A (PEAK)
- Wide Range of Operating Voltage :  $V_{CC} (opr.) = 4.5 \sim 18V$   
 $V_S (opr.) = 0 \sim 18V$   
 $V_{ref} (opr.) = 0 \sim 18V$
- Build in Thermal Shutdown, Over Current Protector and Punch-Through Current Restriction Circuit.
- Hysteresis for All Inputs.

### BLOCK DIAGRAM

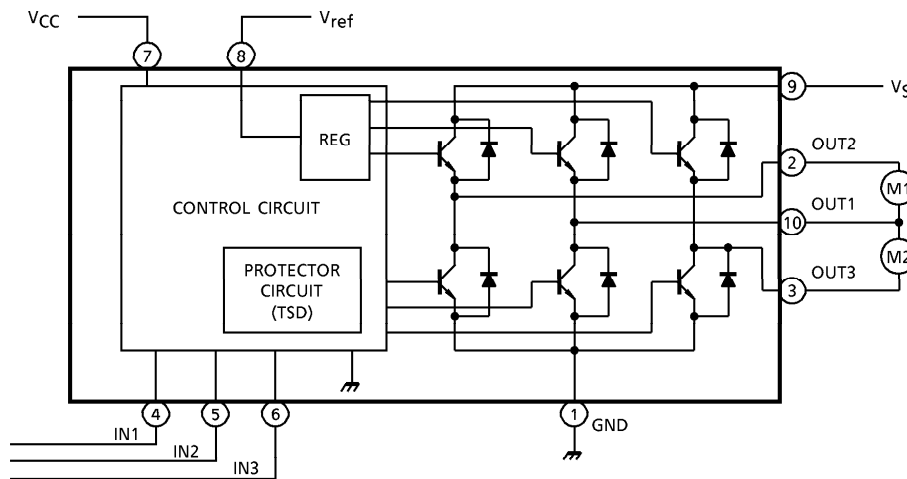

961001EBA2

● TOSHIBA is continually working to improve the quality and the reliability of its products. Nevertheless, semiconductor devices in general can malfunction or fail due to their inherent electrical sensitivity and vulnerability to physical stress. It is the responsibility of the buyer, when utilizing TOSHIBA products, to observe standards of safety, and to avoid situations in which a malfunction or failure of a TOSHIBA product could cause loss of human life, bodily injury or damage to property. In developing your designs, please ensure that TOSHIBA products are used within specified operating ranges as set forth in the most recent products specifications. Also, please keep in mind the precautions and conditions set forth in the TOSHIBA Semiconductor Reliability Handbook.

PIN FUNCTION

PIN No.	SYMBOL	FUNCTIONAL DESCRIPTION
1	GND	GND terminal
2	OUT2	Output terminal
3	OUT3	Output terminal
4	IN1	Input terminal
5	IN2	Input terminal
6	IN3	Input terminal
7	V <sub>CC</sub>	Supply voltage terminal for Logic
8	V <sub>ref</sub>	Supply voltage terminal for control
9	V <sub>S</sub>	Supply voltage terminal for Motor drive
10	OUT1	Output terminal

INPUT CIRCUIT

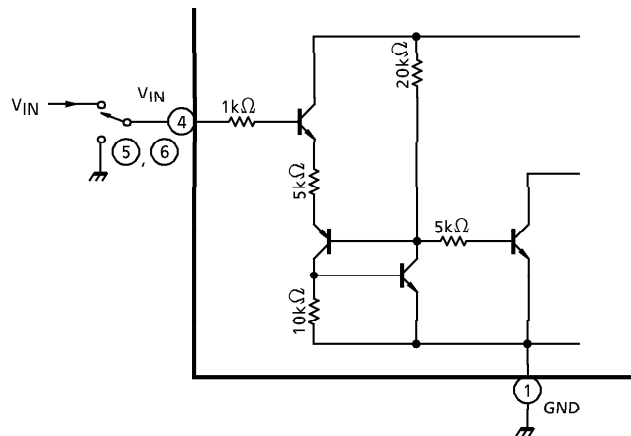

Input terminals of pin④, ⑤ and pin⑥ are all high active type and have a hysteresis of 0.7V (Typ.)  
 5μA type of source mode input current is required.

961001EBA2'

- The products described in this document are subject to foreign exchange and foreign trade control laws.
- The information contained herein is presented only as a guide for the applications of our products. No responsibility is assumed by TOSHIBA CORPORATION for any infringements of intellectual property or other rights of the third parties which may result from its use. No license is granted by implication or otherwise under any intellectual property or other rights of TOSHIBA CORPORATION or others.
- The information contained herein is subject to change without notice.

OUTPUT CIRCUIT

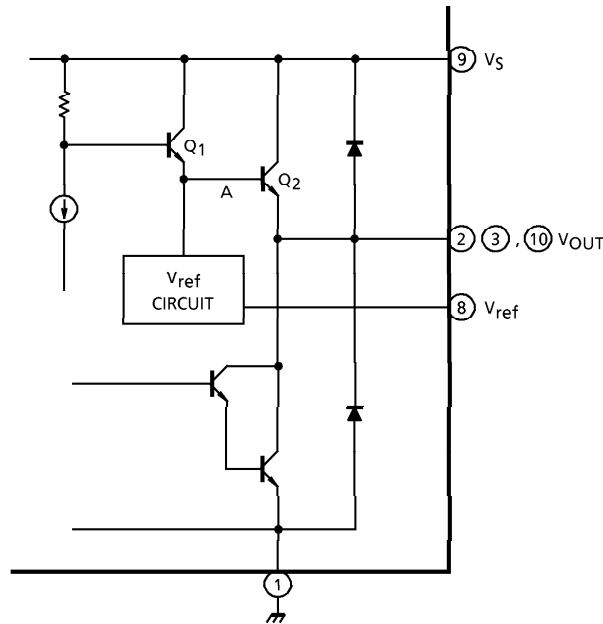

Output voltage is controlled by  $V_{ref}$  voltage. Relationship between  $V_{OUT}$  and  $V_{ref}$  is

$$V_{OUT} = V_{BE} (\approx 0.7) + V_{ref}$$

$V_{ref}$  terminal required to connect to  $V_s$  terminal for stable operation in case of no requirement of  $V_{OUT}$  control.

FUNCTION

INPUT			OUTPUT			MODE	
IN1	IN2	IN3	OUT1	OUT2	OUT3	M1	M2
0	0	1/0	L	L	L	BRAKE	BRAKE
1	0	0	H	L	$\infty$	CW / CCW	STOP
1	0	1	L	H	$\infty$	CCW / CW	STOP
0	1	0	H	$\infty$	L	STOP	CW / CCW
0	1	1	L	$\infty$	H	STOP	CCW / CW
1	1	1/0	L	L	L	BRAKE	BRAKE

$\infty$  : High impedance

(Note) Inputs are all high active type.

**MAXIMUM RATINGS** (Ta = 25°C)

CHARACTERISTIC	SYMBOL	RATING	UNIT	
Supply Voltage	V <sub>CC</sub>	25	V	
Motor Drive Voltage	V <sub>S</sub>	25	V	
Reference Voltage	V <sub>ref</sub>	25	V	
Output Current	PEAK	I <sub>O</sub> (PEAK)	2.0 (Note 1)	A
	AVE.	I <sub>O</sub> (AVE.)	1.0	A
Power Dissipation	P <sub>D</sub>	12.5 (Note 2)	W	
Operating Temperature	T <sub>opr</sub>	- 30~75	°C	
Storage Temperature	T <sub>stg</sub>	- 55~150	°C	

(Note 1) Duty 1 / 10, 100ms

(Note 2) T<sub>c</sub> = 25°C

**ELECTRICAL CHARACTERISTICS** (Unless otherwise noted, Ta = 25°C, V<sub>CC</sub> = 12V, V<sub>S</sub> = 18V)

CHARACTERISTIC	SYMBOL	TEST CIR-CUIT	TEST CONDITION	MIN.	TYP.	MAX.	UNIT	
Supply Current	I <sub>CC1</sub>	1	Output OFF CW / CCW mode	—	17	30	mA	
	I <sub>CC2</sub>	1	Output OFF Brake mode	—	13	25		
Input Voltage	1 (High)	V <sub>IN</sub> (H)	T <sub>j</sub> = 25°C pin④, ⑤, ⑥	3.5	—	5.5	V	
	2 (Low)	V <sub>IN</sub> (L)	T <sub>j</sub> = 25°C pin④, ⑤, ⑥	GND	—	0.8		
Input Current	I <sub>IN</sub>	2	V <sub>IN</sub> = 3.5V, Sink mode	—	5	20	μA	
Input Hysteresis Voltage	ΔV <sub>T</sub>	2	—	—	0.7	—	V	
Saturation Voltage	Upper	V <sub>SAT U-1</sub>	3	V <sub>ref</sub> = V <sub>S</sub> , V <sub>S</sub> - V <sub>out</sub> , I <sub>O</sub> = 0.2A	—	0.9	1.2	V
	Lower	V <sub>SAT L-1</sub>	3	V <sub>ref</sub> = V <sub>S</sub> , V <sub>out</sub> - GND, I <sub>O</sub> = 0.2A	—	1.0	1.3	V
	Upper	V <sub>SAT U-2</sub>	3	V <sub>ref</sub> = V <sub>S</sub> , V <sub>S</sub> - V <sub>out</sub> , I <sub>O</sub> = 1.0A	—	1.3	1.6	V
	Lower	V <sub>SAT L-2</sub>	3	V <sub>ref</sub> = V <sub>S</sub> , V <sub>out</sub> - GND, I <sub>O</sub> = 1.0A	—	1.8	2.5	V
Output Voltage	V <sub>SAT U-1'</sub>	3	V <sub>ref</sub> = 10V, V <sub>out</sub> - GND I <sub>O</sub> = 0.5A	10.7	11.0	11.8	V	
	V <sub>SAT U-2'</sub>	3	V <sub>ref</sub> = 10V, V <sub>out</sub> - GND I <sub>O</sub> = 1.0A	10.4	10.7	11.5	V	
Leakage Current	Upper	I <sub>LU</sub>	—	V <sub>S</sub> = 25V	—	—	50	μA
	Lower	I <sub>LL</sub>	—	V <sub>S</sub> = 25V	—	—	50	
Diode Forward Voltage	Upper	V <sub>F U</sub>	4	I <sub>F</sub> = 1A	—	2.2	—	V
	Lower	V <sub>F L</sub>	4	I <sub>F</sub> = 1A	—	1.4	—	
Reference Current	I <sub>ref</sub>	2	V <sub>ref</sub> = 10V, Source mode	—	5	30	μA	

TEST CIRCUIT 1

$I_{CC1, 2}$

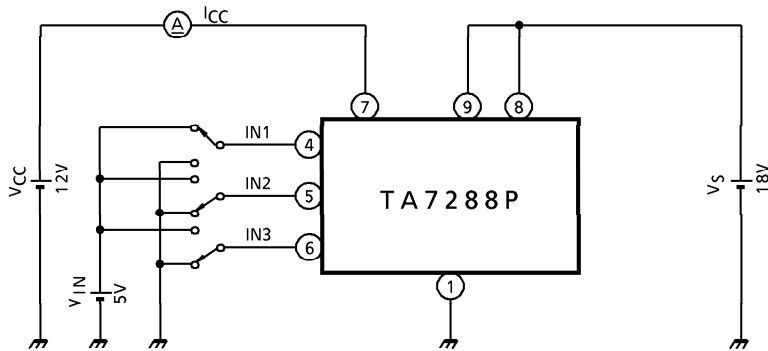

TEST CIRCUIT 2

$V_{IN(H)}$ ,  $V_{IN(L)}$ ,  $I_{IN}$ ,  $\Delta V_T$ ,  $I_{ref}$

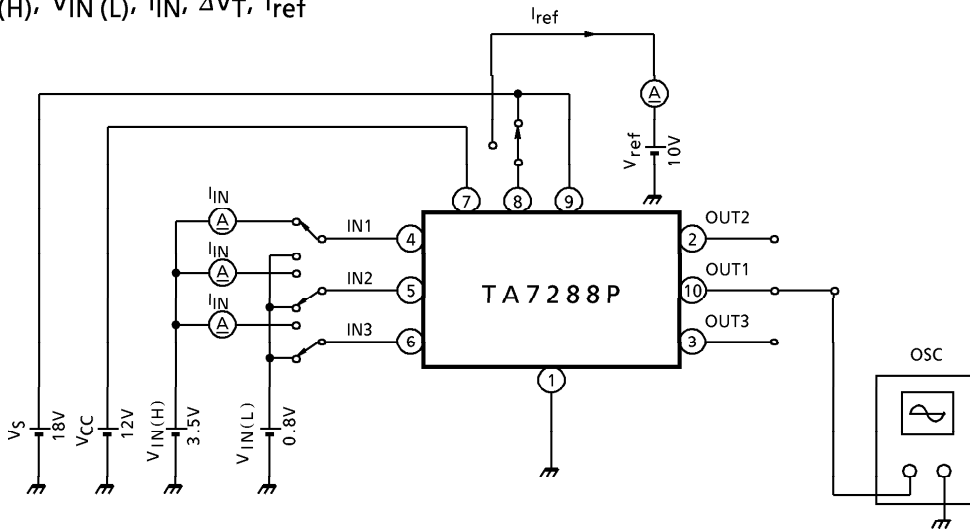

TEST CIRCUIT 3

$V_{SAT U-1, L-1, U-2, L-2, U-1', U-2'}$

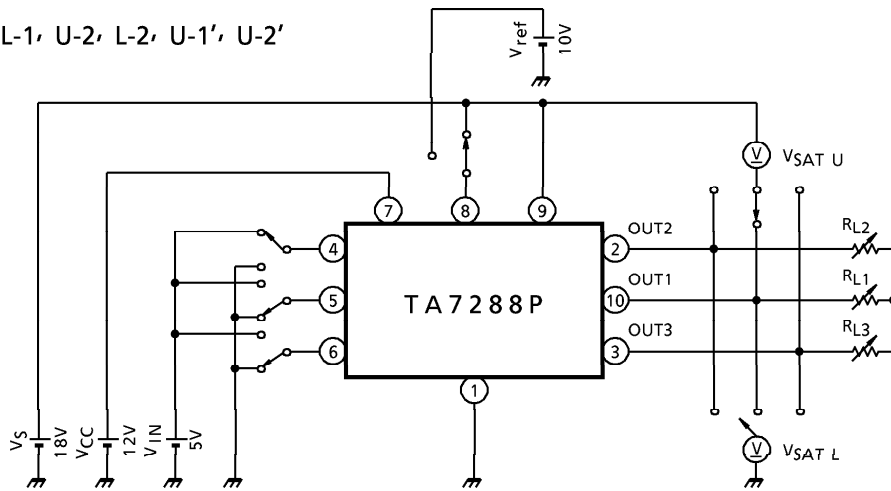

$I_O$  calibration is required to adjust specified values of test conditions by  $R_{L1} \sim R_{L3}$ .

TEST CIRCUIT 4

$V_{FU, L}$

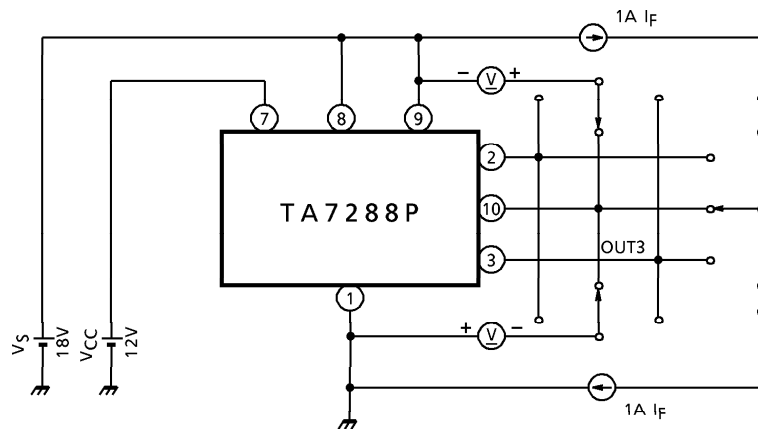

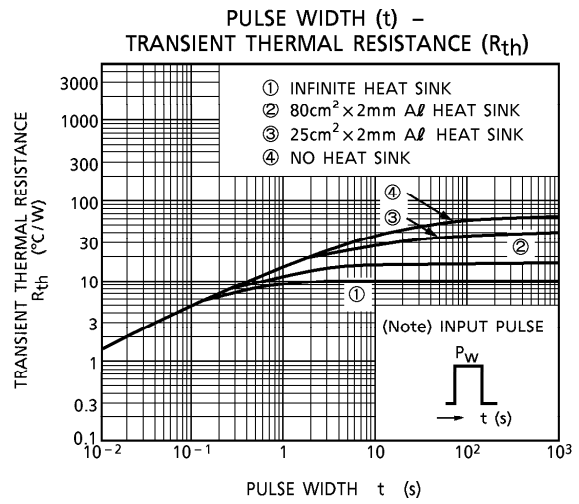
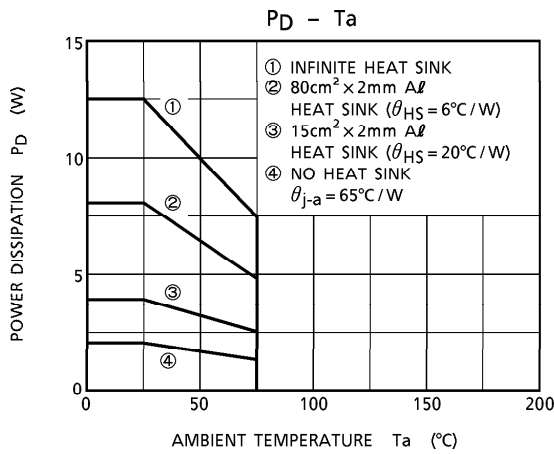

**APPLICATION CIRCUIT**

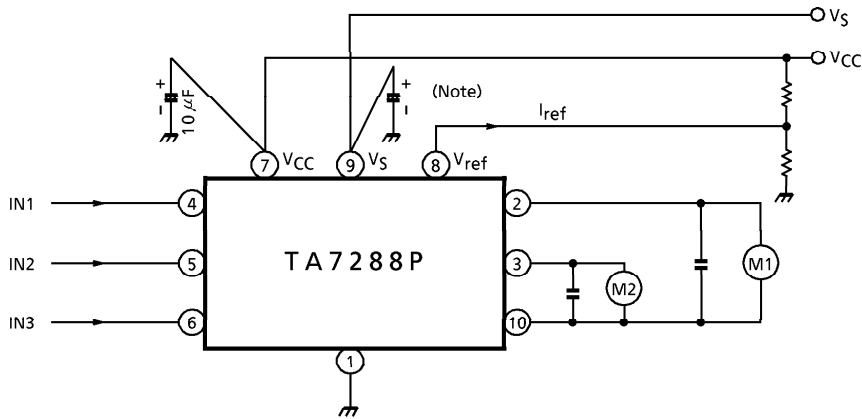

- (Note 1) Connect if required
- (Note 2) Utmost care is necessary in the design of the output line,  $V_S$  and GND line since IC may be destroyed due to short-circuit between outputs, air contamination fault, or fault by improper grounding.

OUTLINE DRAWING  
HSIP10-P-2.54

Unit : mm

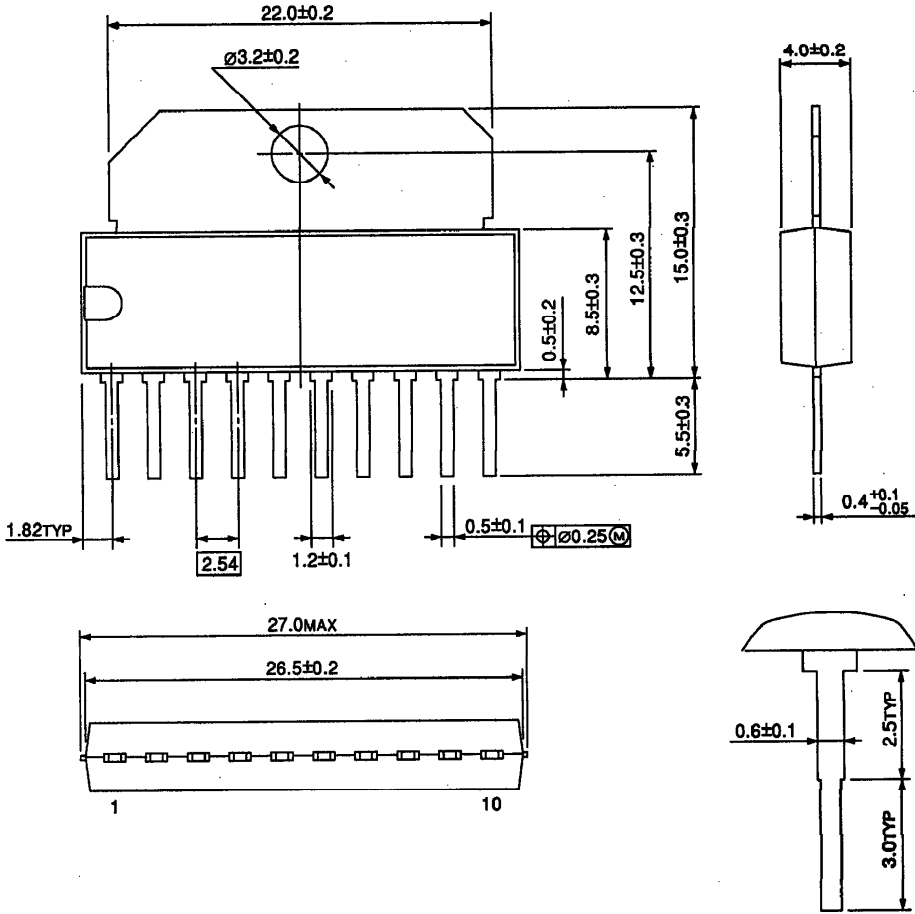

Weight : 2.47g (Typ.)