

TA8063F

4CH HIGH SIDE DRIVER

TA8063F is built into for 0.5A High-side driver ICs which drive lamp, relay, and solenoid actuators. Inputs from DI1, DI2, DI3, and DI4 switch ON and OFF modes. Inputs are TTL-compatible, thus the device can also be directly controlled from a CPU or other control system. The device is equipped with low-standby (with all outputs off), self-diagnosis, and protection functions.

FEATURES

- 0.5A high-side driver.
- Four built-in circuits (power supply, self-diagnosis, and protection functions for each circuit)
- Low standby current 0.1mA (Max.)
- Self-diagnosis output
 - Short : 1A (Typ.)
 - $\overline{DG1}$: OR output of OUT1 & OUT2
 - $\overline{DG2}$: OR output of OUT3 & OUT4
- Multiple protection functions
 - Short, thermal, and overvoltage protection functions
- Built-in diodes for absorbing counter electromotive force
- 20-pin surface mount type plastic package : HSOP20-P-450-1.00

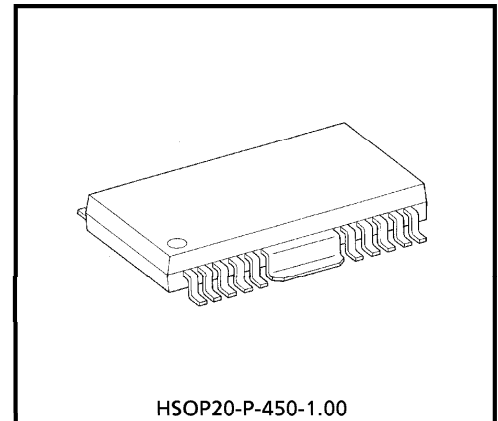

Weight : 0.79g (Typ.)

980910EBA1

- TOSHIBA is continually working to improve the quality and the reliability of its products. Nevertheless, semiconductor devices in general can malfunction or fail due to their inherent electrical sensitivity and vulnerability to physical stress. It is the responsibility of the buyer, when utilizing TOSHIBA products, to observe standards of safety, and to avoid situations in which a malfunction or failure of a TOSHIBA product could cause loss of human life, bodily injury or damage to property. In developing your designs, please ensure that TOSHIBA products are used within specified operating ranges as set forth in the most recent products specifications. Also, please keep in mind the precautions and conditions set forth in the TOSHIBA Semiconductor Reliability Handbook.
- The products described in this document are subject to the foreign exchange and foreign trade laws.
- The information contained herein is presented only as a guide for the applications of our products. No responsibility is assumed by TOSHIBA CORPORATION for any infringements of intellectual property or other rights of the third parties which may result from its use. No license is granted by implication or otherwise under any intellectual property or other rights of TOSHIBA CORPORATION or others.
- The information contained herein is subject to change without notice.

BLOCK DIAGRAM AND PIN ASSIGNMENT

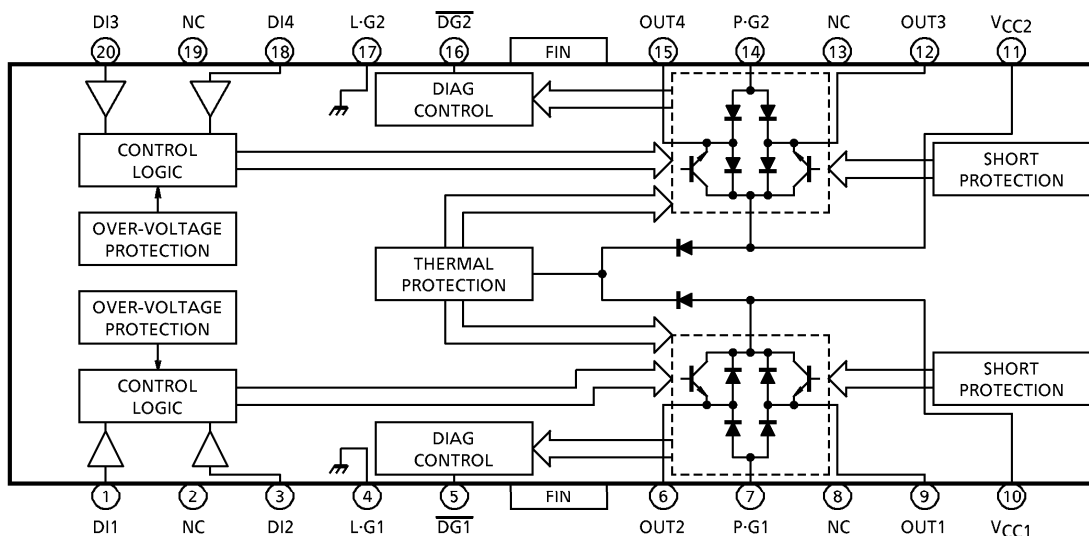

PIN DESCRIPTION

PIN No.	SYMBOL	DESCRIPTION
1, 20 3, 18	DI1, DI3 DI2, DI4	Input pins used to control output. H : output on (See Table 1, Truth Table.)
4, 17	L-G1, L-G2	Ground pins for Logic portion.
5, 16	$\overline{DG1}$, $\overline{DG2}$	Self-diagnosis output pins (See Table 2, Truth Table & Timing Chart.) NPN transistor open-collector output. When output becomes overcurrent, set to on; duty 97% on (low). At normal operation, set to open (high). $\overline{DG1}$: OR output of OUT1 & OUT2 $\overline{DG2}$: OR output of OUT3 & OUT4
6, 15 9, 12	OUT2, OUT4 OUT1, OUT3	Connected to load, with source 0.5A. Features overcurrent detection function to protect IC from instantaneous destruction at load short (See section on Multiple Protections below.) Features diodes for absorbing counter electromotive force built into both V _{CC} and GND sides.
7, 14	P-G1, P-G2	Ground pins for output portion.
10, 11	V _{CC1} , V _{CC2}	Power supply pin. When more than 30V is applied, overvoltage protection function turns off output to protect the IC and motor load.
2, 8, 13, 19	NC	Not connected. (Electrically, this pin is completely open.)

TRUTH TABLE 1 : I/O

INPUT	OUTPUT	OPERATING MODE
DI1/2/3/4	OUT1/2/3/4	
H	ON	
L	OFF	
ALL L	OFF (High impedance)	standby

TRUTH TABLE 2 : SELF DIAGNOSIS

OUTPUT		OUTPUT	DIAG
OUT1/3	OUT2/4	LOAD	
ON	OFF	Normal	H
		Short	L*
OFF	ON	Normal	H
		Short	L*
OFF	OFF	—	H
ON	ON	Normal	H
		Short	L*

* TIMING CHART

SELF DIAGNOSIS TIMIGN CHART

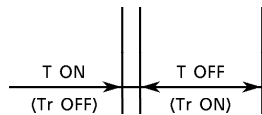
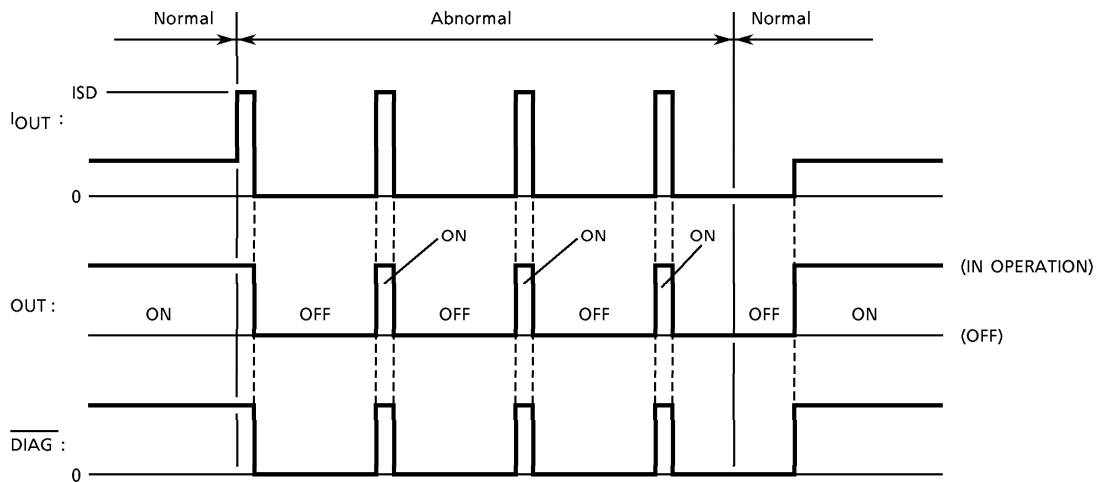

$$\frac{T_{ON}}{T_{ON} + T_{OFF}} = 3\%$$

MULTIPLE PROTECTION OPERATION

TA8069F features built-in overvoltage (V_{SD}), overcurrent (I_{SD}), and thermal (T_{SD}) protection functions. These functions protect TA8069F (sometimes motors, too) from deterioration or destruction due to overpower stress.

The functions are independent from each other.

Functions are described below.

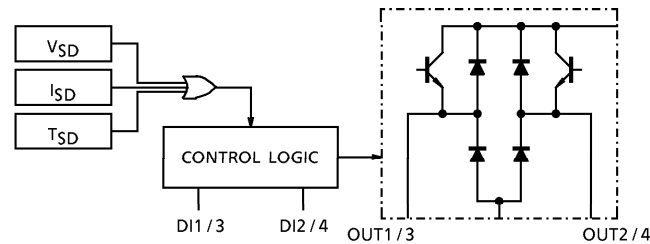

1. Overvoltage protection (V_{SD})

- Outline

When the voltage supplied to the V_{CC} pin is less than the V_{SD} detection voltage, output is controlled by input signals. When the V_{CC} voltage is greater than the V_{SD} detection voltage, output becomes high impedance (off) regardless of input signals.

- Operation

The V_{SD} voltage is detected by comparing the zener voltage with the voltage obtained by dividing V_{CC} by the resistance. If the center voltage of the resistance is higher than the zener voltage, a transistor-off instruction is issued to the control logic portion; if lower, the logic portion is controlled by input signals.

2. Thermal protection (T_{SD})

- Outline

When the junction temperature (chip temperature) is less than the T_{SD} detection temperature, output is controlled by input signals. When the junction temperature is greater than the detection temperature, output becomes high impedance regardless of input signals.

- Operation

The temperature is detected by monitoring V_F of diodes on the chip. If the diode V_F is lower than the internal reference voltage, a transistor-off instruction is issued to the logic portion; if higher, the logic portion is controlled by input signals.

3. Overcurrent protection (I_{SD})

- Outline

When the output current is less than the I_{SD} detection current, output is controlled by input signals. When the output current is greater than the detection current, output changes to switching waveform as in Figure 1.

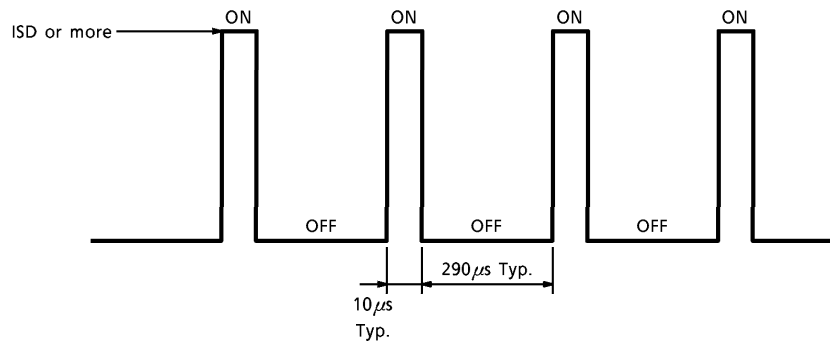

Figure 1 Switching Waveforms

- Operation

The output current is detected by monitoring the sense resistance. Detection circuits are connected to the self-diagnosis output pins ($\overline{DG1}$ and $\overline{DG2}$), then further connected to the short circuit protection circuits. When current exceeding the I_{SD} detection current flows to one of the two channels of self-diagnosis output, the corresponding short circuit protection circuit is activated. The short circuit protection circuit is built into the timer. If overcurrent mode continues $10\mu s$ (Typ.), the circuit changes the output to high impedance mode, then returns to on mode after $290\mu s$ (Typ.). The above switching waveform is output repeatedly as long as the circuit is in overcurrent mode.

- Caution for application

The overcurrent protection is used to protect the IC from instantaneous destruction due to short circuits. If overcurrent continues, configure a system which changes the IC to standby mode using the self diagnosis signal.

Note that the time required for switching the IC from output short (overcurrent detection) to standby must be 1s or less.

MAXIMUM RATING (Ta = 25°C)

CHARACTERISTIC	SYMBOL	RATING	UNIT
Power Supply Voltage	V _{CC}	30	V
	V _{CC}	60 (1s)	
Input Voltage	V _{IN}	- 0.3V~V _{CC} + 0.3	V
Output Current	I _{O·AVE}	0.5	A
Operating Temperature	T _{opr}	- 40~110	°C
Storage Temperature	T _{stg}	- 55~150	°C
Lead Temperature Time	T _{sol}	260 (10s)	°C

HSOP20-P-450-1.00 THERMAL RESISTANCE DATA (Ta = 25°C)

CHARACTERISTIC	RATING	UNIT	TEST CONDITION
R _{θj-a}	125	°C/W	—
R _{θj-c}	13	°C/W	—
P _{D1}	1.0	W	Without radiation board
P _{D2}	1.5	W	60 × 30 × 1.6mm 50% Cu mounted
P _{D3}	3.2	W	50 × 50 × 1.0mm Iron board mounted
P _{D4}	9.6	W	Infinite radiation board mounted

HSOP20-P-450-1.00 TRANSIENT THERMAL RESISTANCE DATA

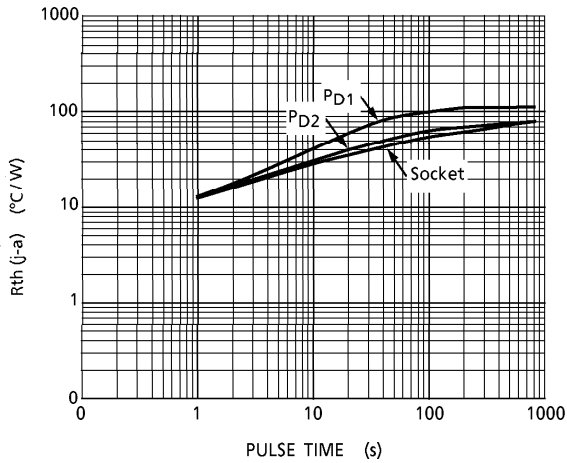

ELECTRICAL CHARACTERISTICS (Unless otherwise specified, $V_{CC} = 8 \sim 16V$, $T_a = -40 \sim 110^\circ C$)

CHARACTERISTICS	SYMBOL	PIN	TEST CIR-CUIT	TEST CONDITION	MIN.	TYP.	MAX.	UNIT
Power Supply Current	I_{CC1}	V_{CC1}/V_{CC2} Total	—	All output : OFF	—	—	0.1	mA
	I_{CC2}		—	1 of 4 output : ON	—	20	30	
	I_{CC3}		—	2 of 4 output : ON	—	35	60	
	I_{CC4}		—	3 of 4 output : ON	—	50	80	
	I_{CC5}		—	All output : ON	—	65	100	
Input Voltage	V_{IL}	DI1/2/3/4	—	—	—	—	0.8	V
	V_{IH}		—	—	2.0	—	—	
Input Current	I_{IL}	DI1/2/3/4	—	$V_{IN} = 0.4V$	—	10	20	μA
	I_{IH}		—	$V_{IN} = 5V$	—	300	600	
Output Saturation Voltage	V_{OH}	OUT1/2/3/4	—	$I_O = 0.4A$	—	1.1	1.3	V
Output Leakage Current	I_{LEAK-U}	OUT1/2/3/4	—	$V_{OUT} = 0V$	-10	—	—	μA
	I_{LEAK-L}		—	$V_{OUT} = V_{CC}$	—	—	10	
Diode Forward Voltage	V_{F-U}	OUT1/2/3/4	—	$I_F = 0.4A$	—	1.5	—	V
	V_{F-L}		—		—	1.5	—	
Output Voltage	V_{OL}	$\overline{DIAG1/2}$	—	$I_{OL} = 3mA$	—	—	0.5	V
Output Leakage Current	I_{LEAK}	$\overline{DIAG1/2}$	—	$V_{OUT} = V_{CC}$	—	—	10	μA
Overcurrent Detection	I_{SD}	—	—	—	—	1.0	—	A
Shutdown Temperature	T_{SD}	—	—	—	—	150	—	$^\circ C$
Overvoltage Detection	V_{SD}	—	—	—	—	30	—	V
Transfer Delay Time	t_{PLH}	—	—	—	—	1	10	μS
	t_{PHL}	—	—	—	—	1	10	

APPLICATION CIRCUIT

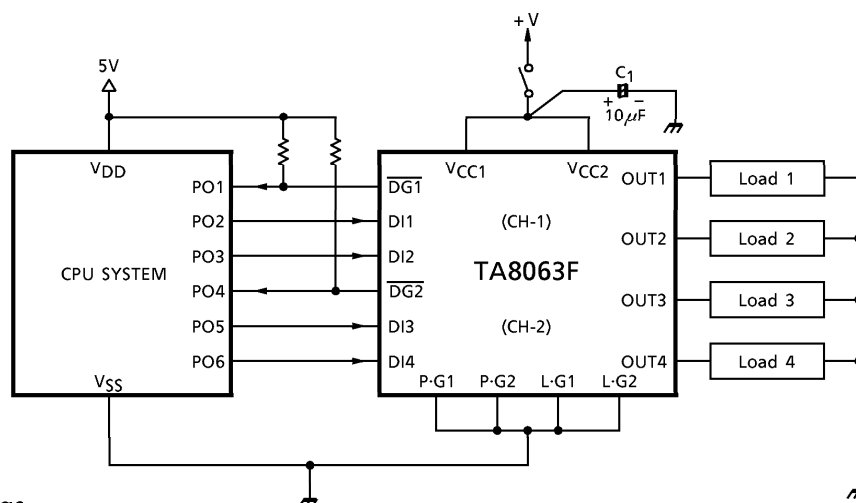

* Cautions for wirings
 C_1 is used for absorbing disturbance or noise. Connect C_1 as near the IC as possible.

I/O EQUIVALENT CIRCUIT

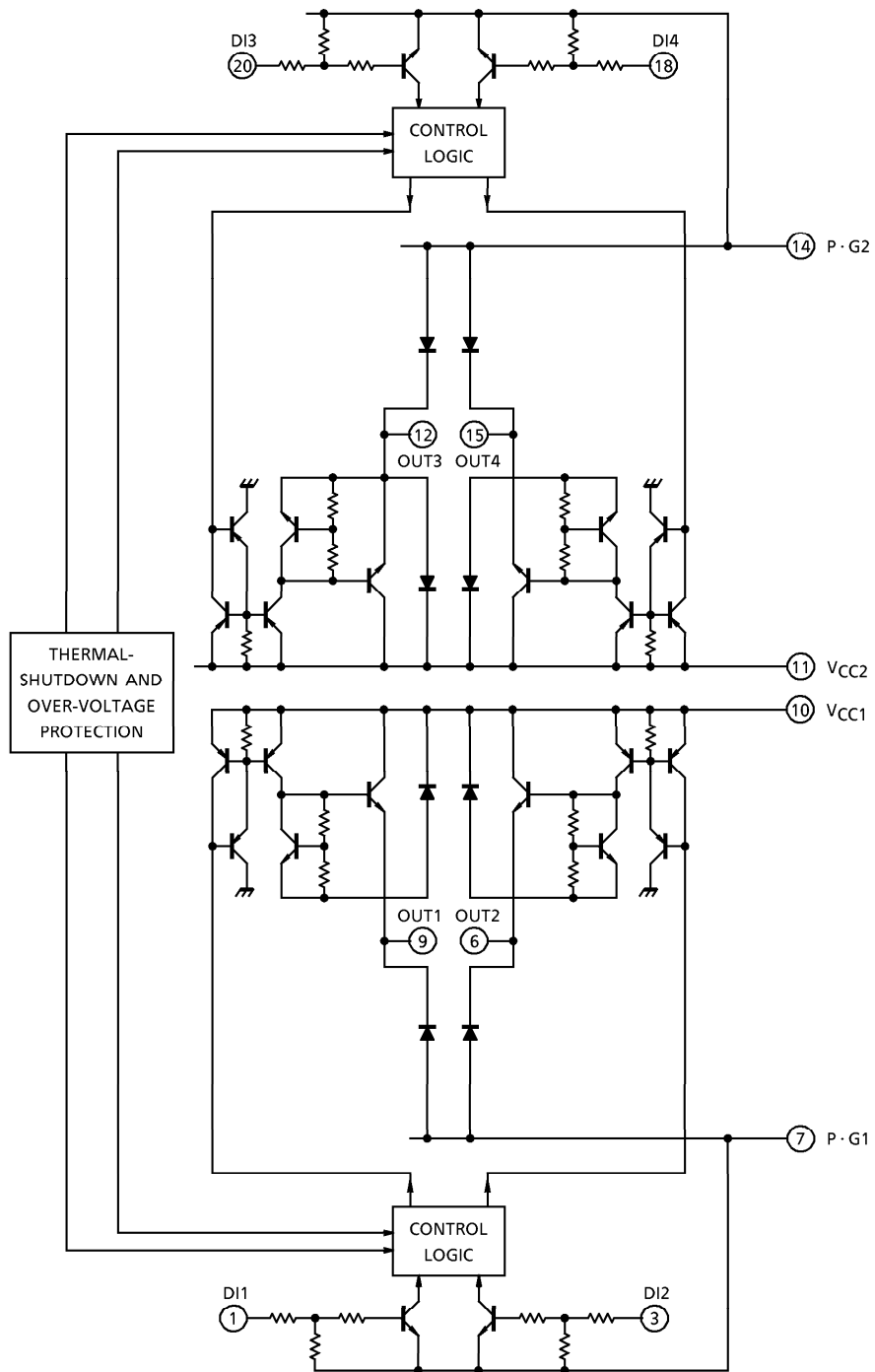

OUTLINE DRAWING

HSOP20-P-450-1.00

Unit : mm

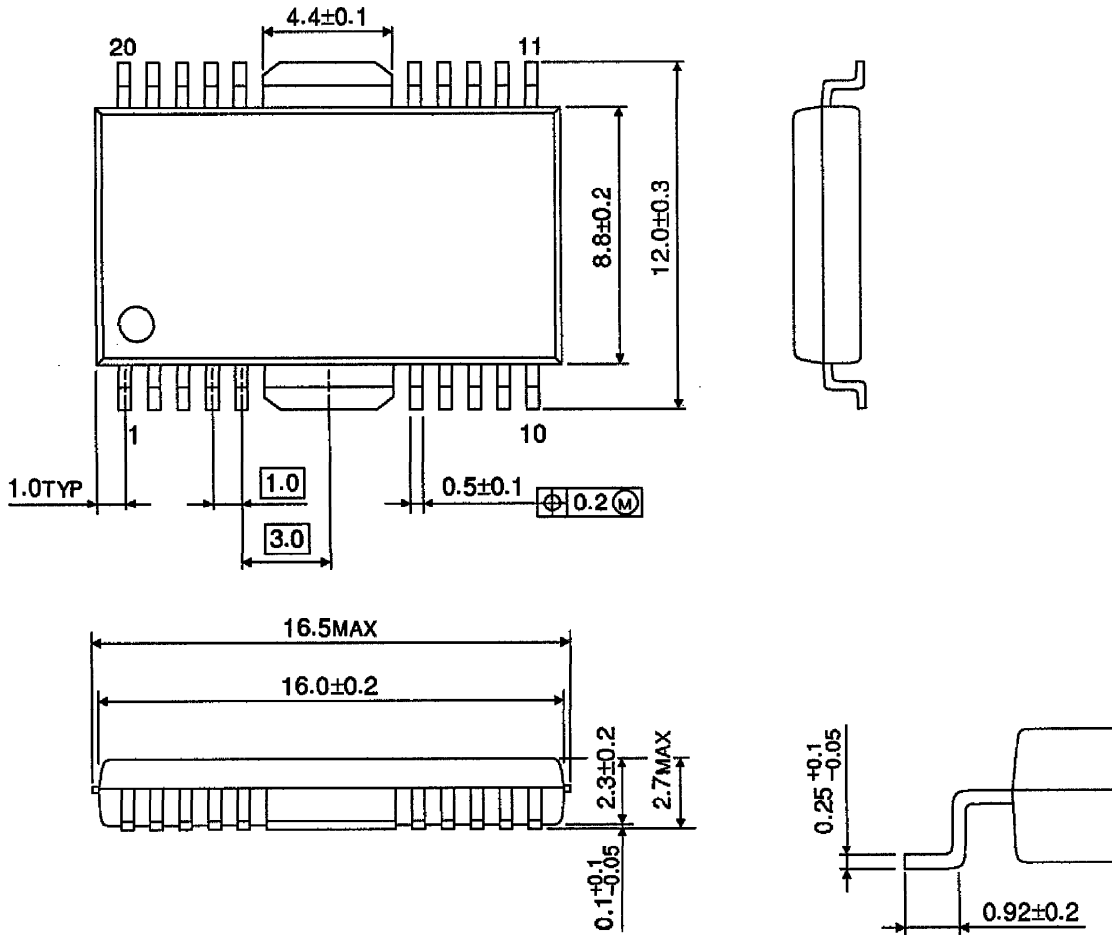

Weight : 0.79g (Typ.)