

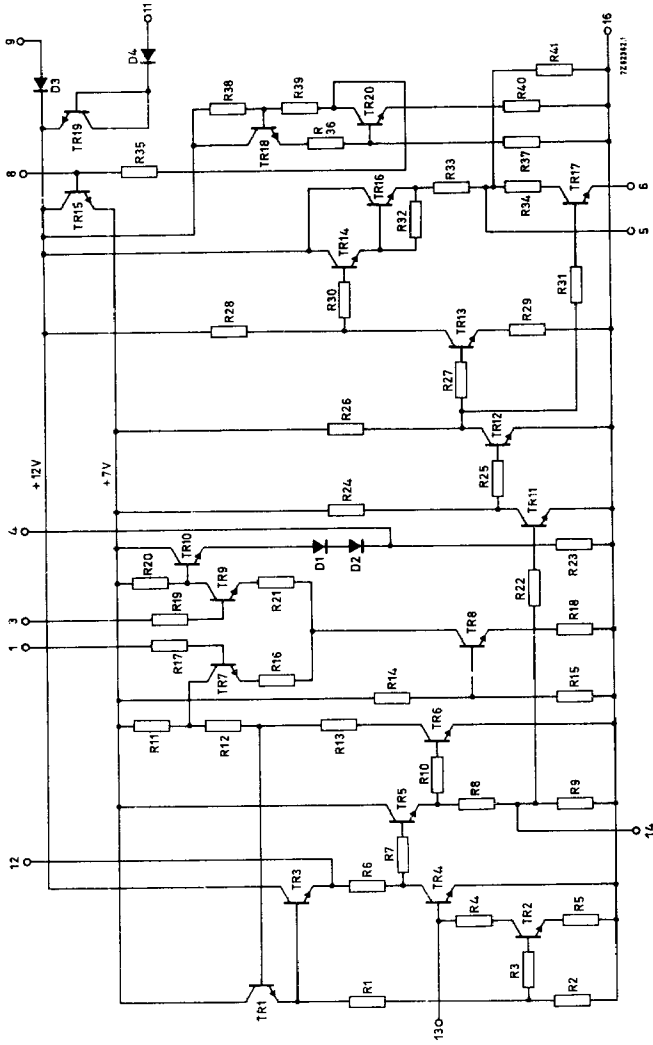

CIRCUIT DIAGRAM



RATINGS Limiting values in accordance with the Absolute Maximum System (IEC134).

Voltages

Supply voltage	V_{11-16}	max.	16 V
Starting voltage	V_{9-16}	max.	15 V

Currents

Output current	I_5	max.	60 mA
----------------	-------	------	-------

Power dissipation

Total power dissipation when mounted on a printed-wiring board	P_{tot}	max.	280 mW
---	-----------	------	--------

Temperatures

Storage temperature	T_{stg}	-55 to +125 °C
Operating ambient temperature	T_{amb}	0 to +60 °C

CHARACTERISTICS Measured in the test set-up on page 4

Supply voltage	V_{11-16}	typ.	12 V 10 to 13 V
Starting voltage	V_{9-16}	>	8 V 1)

CHARACTERISTICS at $T_{amb} = 25$ °C; $V_{11-16} = 12$ V

Supply current 2)	I_{11}	typ.	10,5 mA 7,5 to 13,5 mA
-------------------	----------	------	---------------------------

Required input signals

D.C. control voltage for nominal frequency at pin No. 1 and pin No. 3	$V_{1-16} = V_{3-16}$		2,4 to 5,3 V
Sensitivity of reactance stage	V_{1-3}	typ.	2 kHz/V
Duty cycle regulation at pin No. 14	I_{14}	typ.	0 μ A +400 to -400 μ A

Delivered output signals

Output voltage at pin No. 5 no load; peak-to-peak value	$V_{5-16(p-p)}$	typ.	8 V
Output current	I_5	<	60 mA
Duty cycle; without regulation	δ	{ typ.	40 % 35 to 45 %
with regulation	δ		20 to 60 %
Rise time at pin No. 5 leading edge of output pulse	t_r	typ.	200 ns

1) Maximum starting voltage should not exceed the value of the supply voltage minus 1 volt.

2) No load connected to the output. When the output is loaded, the extra current is: $\delta \times I$, in which δ = duty cycle of output pulse and I = current flowing during output pulse.

TBA720A
TBA720AQ

CHARACTERISTICS (continued)

Relative frequency deviation for $\Delta V_{11} = 1 \text{ V}$

2 %

Relative frequency deviation for change of ambient temperature 25 to 55 °C

3 %

Allowable hum-ripple on supply line (peak-to-peak value)

$\Delta V_{11-16}(\text{p-p})$ typ.

100 mV

Test set-up

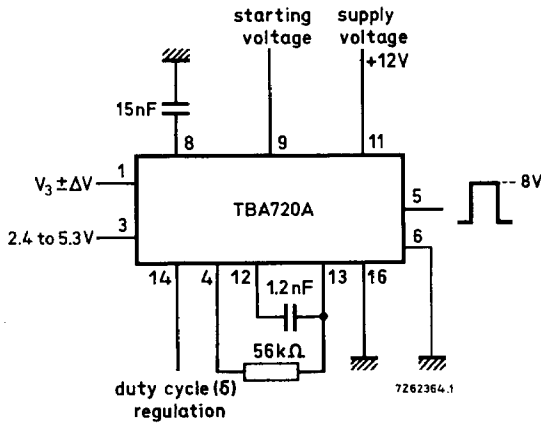

APPLICATION INFORMATION (continued)

Notes

1. The TBA720A is intended to drive a line deflection circuit equipped with transistors.
2. The duty cycle δ can be adjusted by connecting a resistor between pin 14 and ground or the supply.
3. The oscillation frequency can be set between 10 kHz and 25 kHz by connecting a resistor between pins 4 and 13, and a capacitor between pins 12 and 13.
4. At a nominal oscillation frequency of 15,625 kHz, the frequency deviation is limited to $\pm 1,3$ kHz to safeguard the line timebase output circuits.
5. Besides the oscillator, the TBA720A incorporates a reactance stage and a supply voltage take-over switch for starting purposes (pin 9). The latter can be used to advantage if the 12 V supply is derived from the line flyback pulse.
6. Pins 2, 7, 10 and 15 should not be connected.