

10 + 10W STEREO AMPLIFIER WITH MUTE & ST-BY

- WIDE SUPPLY VOLTAGE RANGE UP TO $\pm 20V$
- SPLIT SUPPLY
- HIGH OUTPUT POWER
10 + 10W @ THD = 10%, $R_L = 8\Omega$, $V_S = \pm 14V$
- NO POP AT TURN-ON/OFF
- MUTE (POP FREE)
- STANDBY FEATURE (LOW I_q)
- THERMAL OVERLOAD PROTECTION
- SHORT CIRCUIT PROTECTION TO GND

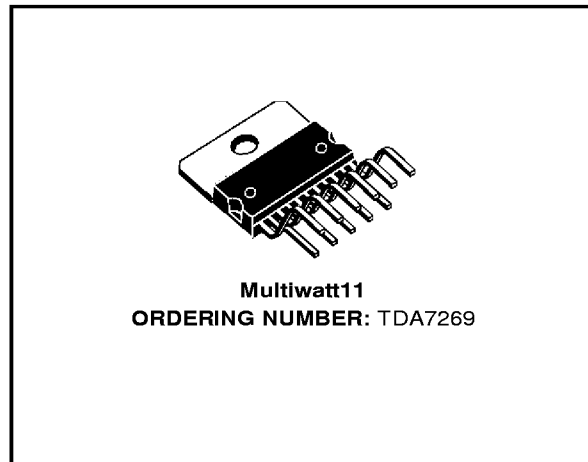

DESCRIPTION

The TDA7269 is class AB dual Audio power amplifier assembled in the Multiwatt package, specially designed for high quality sound application as Hi-Fi music centers and stereo TV sets.

Figure 1: Typical Application Circuit

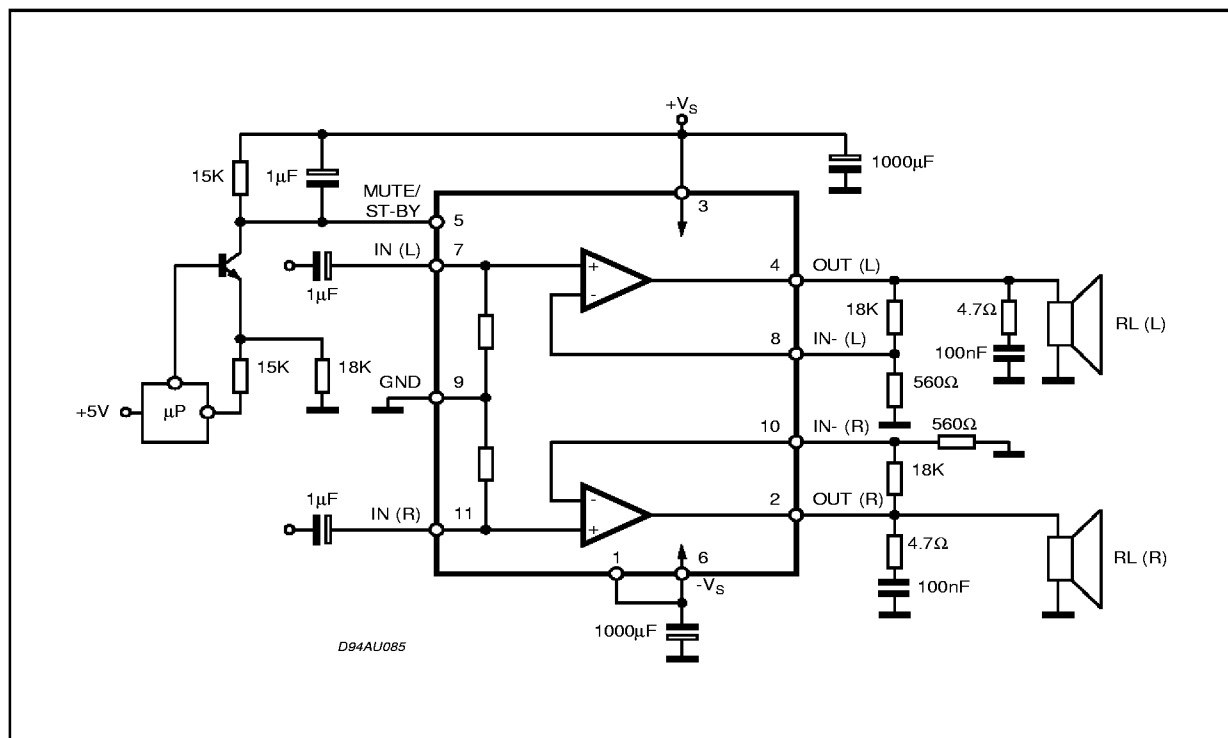

ELECTRICAL CHARACTERISTICS (Refer to the test circuit, $V_S = \pm 14V$; $R_L = 8\Omega$; $R_S = 50\Omega$; $G_V = 30dB$; $f = 1KHz$; $T_{amb} = 25^\circ C$, unless otherwise specified.)

Symbol	Parameter	Test Condition	Min.	Typ.	Max.	Unit
V_S	Supply Range		± 5		± 20	V
I_q	Total Quiescent Current			60	100	mA
V_{OS}	Input Offset Voltage		-25		+25	mV
I_b	Output Bias Current			500		nA
P_O	Output Power	THD = 10% $R_L = 8\Omega$; $V_S \pm 12.5V$; $R_L = 4\Omega$	8 7.5	10 10		W W
		THD = 1% $R_L = 8\Omega$; $V_S \pm 12.5V$; $R_L = 4\Omega$		7.5 7.5		W W
THD	Total Harmonic Distortion	$R_L = 8\Omega$; $P_O = 1W$; $f = 1KHz$		0.03		%
		$R_L = 8\Omega$; $P_O = 0.1$ to $5W$; $f = 100Hz$ to $15KHz$			0.7	%
		$R_L = 4\Omega$; $P_O = 1W$; $f = 1KHz$		0.02		%
		$R_L = 4\Omega$; $V_S \pm 10V$; $P_O = 0.1$ to $5W$; $f = 100Hz$ to $15KHz$			1	%
C_T	Cross Talk	$f = 1KHz$		70		dB
		$f = 10KHz$	50	60		dB
SR	Slew Rate		6.5	10		V/ μs
G_{OL}	Open Loop Voltage Gain			80		dB
e_N	Total Input Noise	A Curve $f = 20KHz$ to $22KHz$		3 4	8	μV μV
R_i	Input Resistance		15	20		K Ω
SVR	Supply Voltage Rejection (each channel)	$f_r = 100Hz$ $V_r = 0.5V$		60		dB
T_j	Thermal Shut-down Junction Temperature			145		$^\circ C$
MUTE FUNCTION [ref: +Vs] (*)						
V_{T_MUTE}	Mute / Play Threshold		-7	-6	-5	V
A_M	Mute Attenuation		60	70		dB
STAND-BY FUNCTION [ref: +Vs] (Only for Split Supply)						
V_{T_ST-BY}	Stand-by / Mute Threshold		-3.5	-2.5	-1.5	V
A_{ST-BY}	Stand-by Attenuation			110		dB
I_{q_ST-BY}	Quiescent Current @ Stand-by			3	6	mA

(*) In mute condition the current drawn from Pin 5 must be $\leq 650\mu A$.

MUTE STAND-BY FUNCTION

The pin 5 (MUTE/STAND-BY) controls the amplifier status by two different thresholds, referred to $+V_s$.

- When V_{pin5} higher than $+V_s - 2.5V$ the amplifier is in Stand-by mode and the final stage generators are off

- when V_{pin5} is between $+V_s - 2.5V$ and $+V_s - 6V$ the final stage current generators are switched on and the amplifier is in mute mode
- when V_{pin5} is lower than $+V_s - 6V$ the amplifier is play mode.

Figure 2

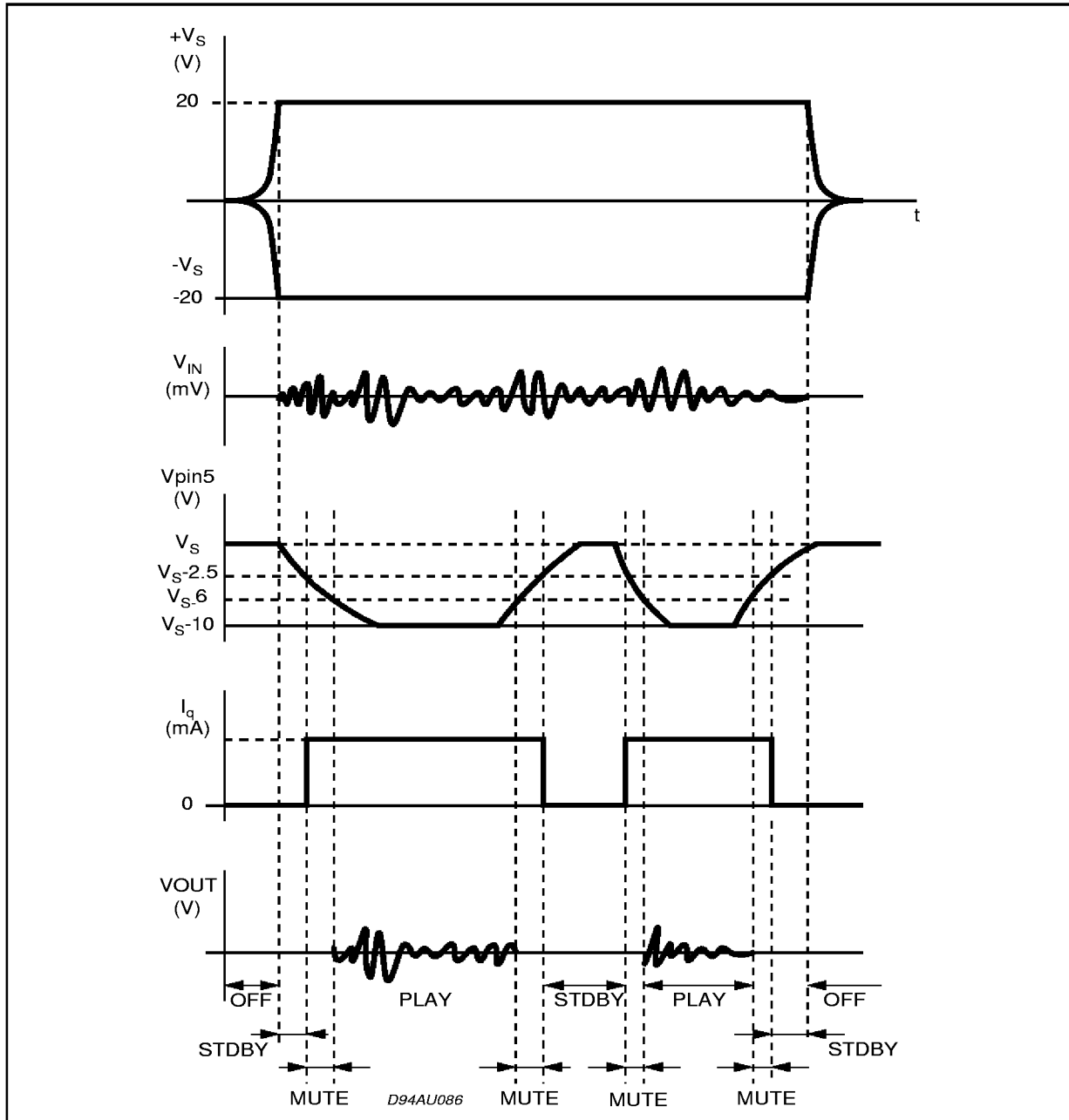
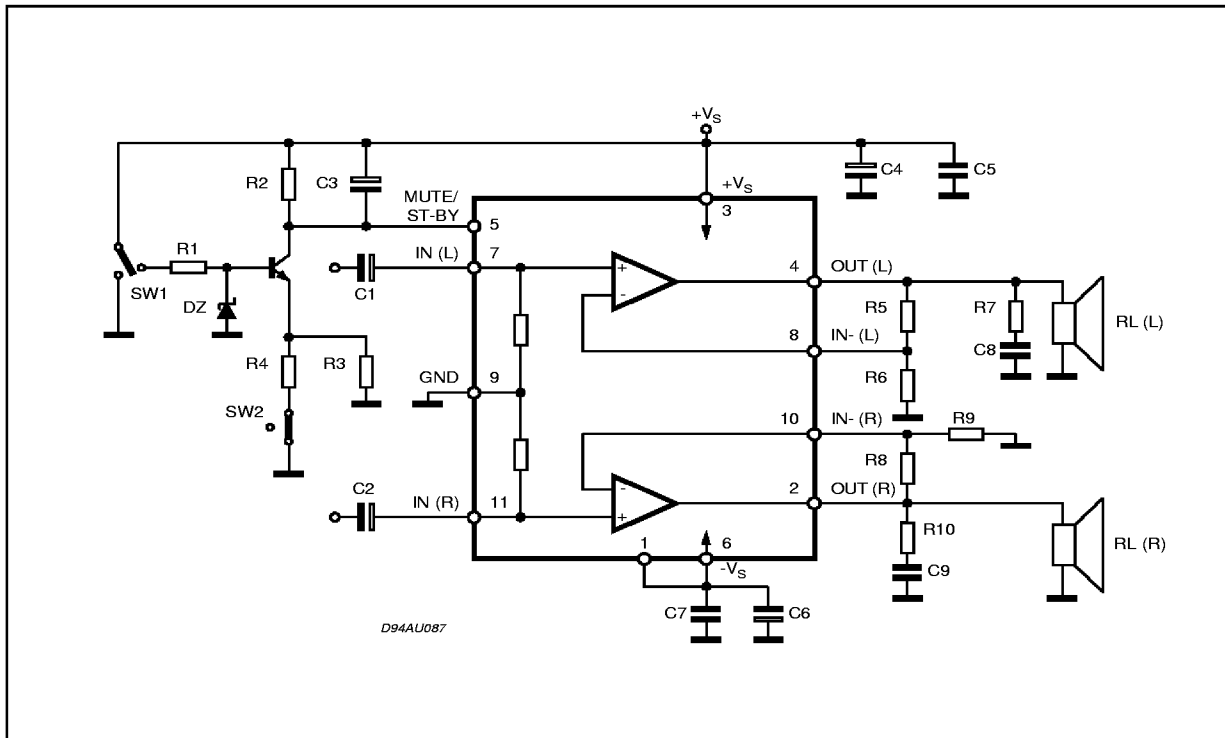

Figure 3: Test and Application Circuit (Stereo Configuration)



APPLICATIONS SUGGESTION
(Demo Board Schematic)

The recommended values of the external compo-

ponents are those shown are the demo board schematic different values can be used: the following table can help the designer.

COMPONENTS	RECOMMENDED VALUE	PURPOSE	LARGER THAN RECOMMENDED VALUE	SMALLER THAN RECOMMENDED VALUE
R1	10KΩ	Mute Circuit	Increase of Dz Biasing Current	
R2	15KΩ	Mute Circuit	V _{pin # 5} Shifted Downward	V _{pin # 5} Shifted Upward
R3	18KΩ	Mute Circuit	V _{pin # 5} Shifted Upward	V _{pin # 5} Shifted Downward
R4	15KΩ	Mute Circuit	V _{pin # 5} Shifted Upward	V _{pin # 5} Shifted Downward
R5, R8	18KΩ	Closed Loop Gain Setting (*)	Increase of Gain	
R6, R9	560Ω		Decrease of Gain	
R7, R10	4.7Ω	Frequency Stability	Danger of Oscillations	Danger of Oscillations
C1, C2	1μF	Input DC Decoupling		Higher Low Frequency Cutoff
C3	1μF	St-By/Mute Time Constant	Larger On/Off Time	Smaller On/Off Time
C4, C6	1000μF	Supply Voltage Bypass		Danger of Oscillations
C5, C7	0.1μF	Supply Voltage Bypass		Danger of Oscillations
C8, C9	0.1μF	Frequency Stability		
Dz	5.1V	Mute Circuit		

(*) Closed loop gain has to be => 25dB

MULTIWATT11 PACKAGE MECHANICAL DATA

DIM.	mm			inch		
	MIN.	TYP.	MAX.	MIN.	TYP.	MAX.
A			5			0.197
B			2.65			0.104
C			1.6			0.063
D		1			0.039	
E	0.49		0.55	0.019		0.022
F	0.88		0.95	0.035		0.037
G	1.57	1.7	1.83	0.062	0.067	0.072
G1	16.87	17	17.13	0.664	0.669	0.674
H1	19.6			0.772		
H2			20.2			0.795
L	21.5		22.3	0.846		0.878
L1	21.4		22.2	0.843		0.874
L2	17.4		18.1	0.685		0.713
L3	17.25	17.5	17.75	0.679	0.689	0.699
L4	10.3	10.7	10.9	0.406	0.421	0.429
L7	2.65		2.9	0.104		0.114
M	4.1	4.3	4.5	0.161	0.169	0.177
M1	4.88	5.08	5.3	0.192	0.200	0.209
S	1.9		2.6	0.075		0.102
S1	1.9		2.6	0.075		0.102
Dia1	3.65		3.85	0.144		0.152

