

# $\mu$ A124 • $\mu$ A224 • $\mu$ A324 • $\mu$ A2902 Quad Operational Amplifiers

Linear Division Operational Amplifiers

### Description

The  $\mu$ A124 series of quad operational amplifiers consists of four independent high gain, internally frequency compensated operational amplifiers designed to operate from a single power supply or dual power supplies over a wide range of voltages. The common mode input range includes the negative supply, thereby eliminating the necessity for external biasing components in many applications. The output voltage range also includes the negative power supply voltage. They are constructed using the Fairchild Planar Epitaxial process.

- **Input Common Mode Voltage Range Includes Ground Or Negative Supply**
- **Output Voltage Can Swing To Ground Or Negative Supply**
- **Four Internally Compensated Operational Amplifiers In A Single Package**
- **Wide Power Supply Range; Single Supply Of 3.0 V to 30 V, Dual Supply of  $\pm 1.5$  V to  $\pm 16$  V**
- **Power Drain Suitable For Battery Operation**

### Absolute Maximum Ratings

Storage Temperature Range	
Ceramic DIP	-65°C to +175°C
Molded DIP and SO-14	-65°C to +150°C
Operating Temperature Range	
Extended ( $\mu$ A124M)	-55°C to +125°C
Automotive ( $\mu$ A2902V)	-40°C to +85°C
Industrial ( $\mu$ A224V)	-25°C to +85°C
Commercial ( $\mu$ A324C)	0°C to +70°C
Lead Temperature	
Ceramic DIP (soldering, 60 s)	300°C
Molded DIP and SO-14 (soldering, 10 s)	265°C
Internal Power Dissipation <sup>1, 2</sup>	
14L-Ceramic DIP	1.36 W
14L-Molded DIP	1.04 W
SO-14	0.93 W
Supply Voltage Between V+ and V-	32 V
Differential Input Voltage <sup>3</sup>	32 V
Input Voltage <sup>3</sup>	-0.3 V (V-) to V+

### Notes

1. T<sub>J</sub> Max = 150°C for the Molded DIP and SO-14, and 175°C for the Ceramic DIP.
2. Ratings apply to ambient temperature at 25°C. Above this temperature derate the 14L-Ceramic DIP at 9.1 mW/°C, the 14L-Molded DIP at 8.3 mW/°C, and the SO-14 at 7.5 mW/°C.
3. The input common mode voltage or either input signal voltage should not be allowed to go negative by more than 0.3 V. The upper end of the common mode voltage range is V<sub>CC</sub> - 1.5 V, but either or both inputs can go to +32 V without damage (+26 V for  $\mu$ A2902).
4. Short circuits from the output to V<sub>CC</sub> can cause excessive heating and eventual destruction. Destructive dissipation can result from simultaneous shorts on all amplifiers.

### Connection Diagram

14-Lead DIP and SO-14 Package  
(Top View)

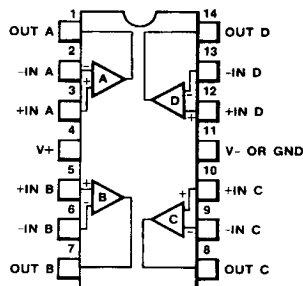

CD00961F

### Order Information

Device Code	Package Code	Package Description
$\mu$ A124DM	6A	Ceramic DIP
$\mu$ A224DV	6A	Ceramic DIP
$\mu$ A224PV	9A	Molded DIP
$\mu$ A324DC	6A	Ceramic DIP
$\mu$ A324PC	9A	Molded DIP
$\mu$ A324SC	KD	Molded Surface Mount
$\mu$ A2902PV	9A	Molded DIP

Equivalent Circuit (1/4 of Circuit)

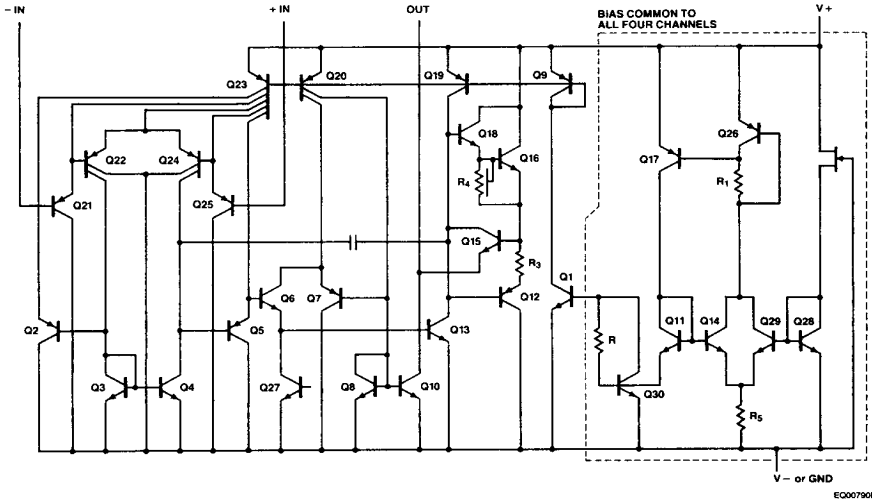

μA124, μA224 and μA324

Electrical Characteristics  $T_A = 25^\circ\text{C}$ ,  $V_+ = 5.0\text{ V}$ ,  $V_- = \text{GND}$ , unless otherwise specified.

Symbol	Characteristic	Condition	μA124/A224			μA324			Unit
			Min	Typ	Max	Min	Typ	Max	
$V_{IO}$	Input Offset Voltage	$V_+ = 5.0\text{ V to }30\text{ V}$ $V_{CM} = 0\text{ V to } (V_-) - 1.5\text{ V}$ , $V_O \approx 1.4\text{ V}$ , $R_S \leq 50\ \Omega$		2.0	5.0		2.0	7.0	mV
$I_{IO}$	Input Offset Current			3.0	30		5.0	50	nA
$I_{IB}$	Input Bias Current			45	150		45	250	nA
CMR	Common Mode Rejection	$R_S \leq 10\text{ k}\Omega$	70	85		65	70		dB
$V_{IR}$	Input Voltage Range	$V_+ = 30\text{ V}$	0		28.5	0		28.5	V
PSRR	Power Supply Rejection Ratio		65	100		65	100		dB
$I_{OS}$	Output Short Circuit Current <sup>1</sup>			40	60		40	60	mA
$I_{O+}$	Output Source Current	$V_{ID} = 1.0\text{ V}$ , $V_+ = 15\text{ V}$	20	40		20	40		mA
$I_{O-}$	Output Sink Current	$V_{ID} = -1.0\text{ V}$ , $V_+ = 15\text{ V}$	10	20		10	20		mA
		$V_{ID} = -1.0\text{ V}$ , $V_O = 200\text{ mV}$	12	50		12	50		μA
$A_{VS}$	Large Signal Voltage Gain	$V_+ = 15\text{ V}$ , $R_L \geq 2.0\text{ k}\Omega$	50	100		25	100		V/mV
CS	Channel Separation	$1.0\text{ kHz} \leq f \leq 20\text{ kHz}$ , (Input Referenced)		-120			-120		dB

μA124, μA224 and μA324 (Cont.)

Electrical Characteristics  $T_A = 25^\circ\text{C}$ ,  $V_+ = 5.0\text{ V}$ ,  $V_- = \text{GND}$ , unless otherwise specified.

Symbol	Characteristic	Condition	μA124/A224			μA324			Unit
			Min	Typ	Max	Min	Typ	Max	
$V_{IO}$	Input Offset Voltage	$V_+ = 5.0\text{ V to }30\text{ V}$ , $V_{CM} = 0\text{ V to }V_- = 2.0\text{ V}$ , $V_O \approx 1.4\text{ V}$ , $R_S \leq 50\ \Omega$			7.0			9.0	mV
$\Delta V_{IO}/\Delta T$	Input Offset Voltage Temperature Sensitivity			7.0			7.0		$\mu\text{V}/^\circ\text{C}$
$I_{IO}$	Input Offset Current				100			150	nA
$\Delta I_{IO}/\Delta T$	Input Offset Current Temperature Sensitivity			10			10		$\text{pA}/^\circ\text{C}$
$I_{IB}$	Input Bias Current			40	300		50	500	nA
$I_{CC}$	Supply Current	$V_O = 0\text{ V}$ , $R_L = \infty$		0.7	1.2		0.7	1.2	mA
		$V_+ = 30\text{ V}$ , $V_O = 0\text{ V}$ , $R_L = \infty$		1.5	3.0		1.5	3.0	
$V_{IR}$	Input Voltage Range	$V_+ = 30\text{ V}$	0		28	0		28	V
$I_{O+}$	Output Source Current	$V_{IO} = +1.0\text{ V}$ , $V_+ = 15\text{ V}$	10	20		10	20		mA
$I_{O-}$	Output Sink Current	$V_{IO} = -1.0\text{ V}$ , $V_+ = 15\text{ V}$	5.0	8.0		5.0	8.0		mA
$A_{VS}$	Large Signal Voltage Gain	$V_+ = 15\text{ V}$ , $R_L \geq 2.0\text{ k}\Omega$	25			15			V/mV
$V_{OH}$	Output Voltage HIGH	$V_+ = 30\text{ V}$ , $R_L = 10\text{ k}\Omega$	27	28		27	28		V
		$V_+ = 30\text{ V}$ , $R_L = 2.0\text{ k}\Omega$	26			26			
$V_{OL}$	Output Voltage LOW	$V_+ = 5.0\text{ V}$ , $R_L = 10\text{ k}\Omega$		5.0	20		5.0	20	mV

μA2902

Electrical Characteristics  $T_A = 25^\circ\text{C}$ ,  $V_+ = 5.0\text{ V}$ ,  $V_- = \text{GND}$ , unless otherwise specified.

Symbol	Characteristic	Condition	Min	Typ	Max	Unit
$V_{IO}$	Input Offset Voltage	$V_+ = 5.0\text{ V to }26\text{ V}$ , $V_{CM} = 0\text{ V to } (V_-) - 1.5\text{ V}$ , $V_O \approx 1.4\text{ V}$ , $R_S \leq 50\ \Omega$		2.0	7.0	mV
$I_{IO}$	Input Offset Current			5.0	50	nA
$I_{IB}$	Input Bias Current			45	250	nA
CMR	Common Mode Rejection	$R_S \leq 10\text{ k}\Omega$	50	70		dB
$V_{IR}$	Input Voltage Range	$V_{CC} = 26\text{ V}$	0		24.5	V
PSRR	Power Supply Rejection Ratio		50	100		dB
$I_{OS}$	Output Short Circuit Current <sup>1</sup>			40	60	mA

**μA2902 (Cont.)**

**Electrical Characteristics**  $T_A = 25^\circ\text{C}$ ,  $V_+ = 5.0\text{ V}$ ,  $V_- = \text{GND}$ , unless otherwise specified.

Symbol	Characteristic	Condition	Min	Typ	Max	Unit
$I_{O+}$	Output Source Current	$V_{ID} = +1.0\text{ V}$ , $V_+ = 15\text{ V}$	20	40		mA
$I_{O-}$	Output Sink Current	$V_{ID} = -1.0\text{ V}$ , $V_+ = 15\text{ V}$	10	20		mA
$A_{VS}$	Large Signal Voltage Gain	$V_+ = 15\text{ V}$ , $R_L \geq 2.0\text{ k}\Omega$	15	100		V/mV
CS	Channel Separation	$1.0\text{ kHz} \leq f \leq 20\text{ kHz}$ , Input Referenced		-120		dB

7

The following specifications apply over the operating temperature range of  $-40^\circ\text{C} \leq T_A \leq +85^\circ\text{C}$

$V_{IO}$	Input Offset Voltage	$V_+ = 5.0\text{ V}$ to $26\text{ V}$ , $V_{CM} = 0\text{ V}$ to $V_- = 2.0\text{ V}$ , $V_O \approx 1.4\text{ V}$ , $R_S \leq 50\ \Omega$			10	mV
$\Delta V_{IO}/\Delta T$	Input Offset Voltage Temperature Sensitivity			7.0		$\mu\text{V}/^\circ\text{C}$
$I_{IO}$	Input Offset Current			45	200	nA
$\Delta I_{IO}/\Delta T$	Input Offset Current Temperature Sensitivity			10		$\text{pA}/^\circ\text{C}$
$I_{IB}$	Input Bias Current			50	500	nA
$I_{CC}$	Supply Current	$V_O = 0\text{ V}$ , $R_L = \infty$		0.7	1.2	mA
		$V_+ = 26\text{ V}$ , $V_O = 0\text{ V}$ , $R_L = \infty$		1.5	3.0	mA
$V_{IR}$	Input Voltage Range	$V_+ = 26\text{ V}$	0		24	V
$I_{O+}$	Output Source Current	$V_{ID} = +1.0\text{ V}$ , $V_+ = 15\text{ V}$	10	20		mA
$I_{O-}$	Output Sink Current	$V_{ID} = -1.0\text{ V}$ , $V_+ = 15\text{ V}$	5.0	8.0		mA
$A_{VS}$	Large Signal Voltage Gain	$V_+ = 15\text{ V}$ , $R_L \geq 2.0\text{ k}\Omega$	15	100		V/mV
$V_{OH}$	Output Voltage HIGH	$V_+ = 26\text{ V}$ , $R_L = 2.0\text{ k}\Omega$	22			V
		$V_+ = 26\text{ V}$ , $R_L = 10\text{ k}\Omega$	23	24		
$V_{OL}$	Output Voltage LOW	$V_+ = 5.0\text{ V}$ , $R_L = 10\text{ k}\Omega$		5.0	100	mV

**Notes**

- Short circuits from the output to  $V_{CC}$  can cause excessive heating and eventual destruction. Destructive dissipation can result from simultaneous shorts on all amplifiers.

**Typical Performance Curves**

**Open Loop Frequency Response**

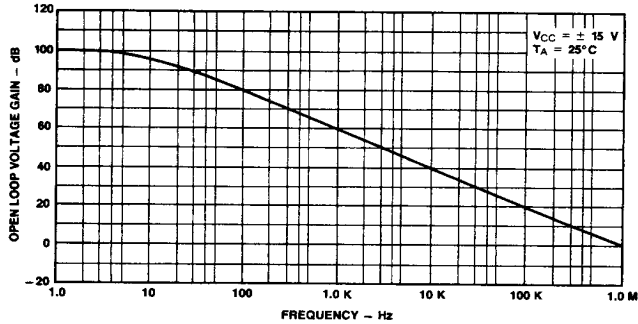

PC04211F

**Output Characteristics Current Sourcing**

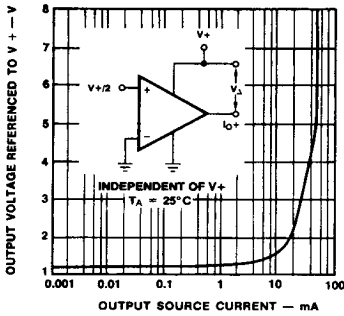

PC04221F

**Output Characteristics Current Sinking**

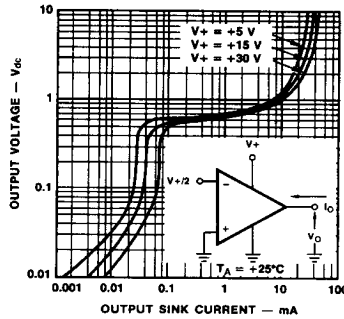

PC04231F

**Output Voltage vs Frequency**

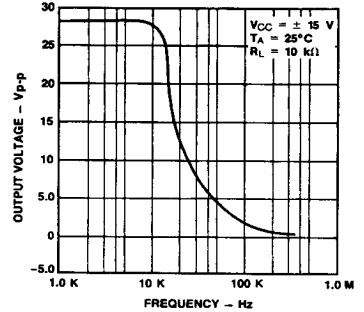

PC04241F

**Output Swing vs Supply Voltage**

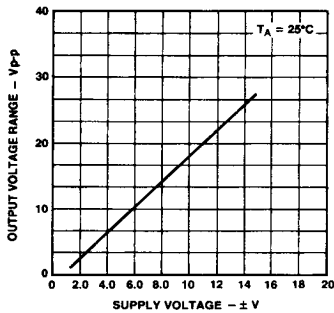

PC04251F

**Input Bias Current vs Temperature**

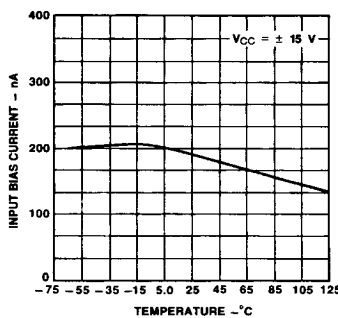

PC04261F

**Input Bias Current vs Supply Voltage**

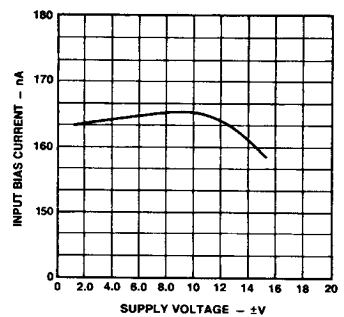

PC04271F