

## CMOS Micropower Over/Under Voltage Detector

April 1994

### Features

- Guaranteed 10 $\mu$ A Maximum Quiescent Current Over Temperature
- Guaranteed Wider Operating Voltage Range Over Entire Operating Temperature Range
- 2% Threshold Accuracy (ICL7665SA)
- Dual Comparator with Precision Internal Reference
- 100ppm/ $^{\circ}$ C Temperature Coefficient of Threshold Voltage
- 100% Tested at 2V
- Output Current Sinking Ability . . . . . Up to 20mA
- Individually Programmable Upper and Lower Trip Voltages and Hysteresis Levels

### Applications

- Pocket Pagers
- Portable Instrumentation
- Charging Systems
- Memory Power Back-Up
- Battery Operated Systems
- Portable Computers
- Level Detectors

### Description

The ICL7665S Super CMOS Micropower Over/Under Voltage Detector contains two low power, individually programmable Voltage detectors on a single CMOS chip. Requiring typically 3 $\mu$ A for operation, the device is intended for battery-operated systems and instruments which require high or low voltage warnings, settable trip points, or fault monitoring and correction. The trip points and hysteresis of the two voltage detectors are individually programmed via external resistors. An internal bandgap-type reference provides an accurate threshold voltage while operating from any supply in the 1.6V to 16V range.

The ICL7665S, Super Programmable Over/Under Voltage Detector is a direct replacement for the industry standard ICL7665B offering **wider** operating voltage and temperature ranges, **improved** threshold accuracy (ICL7665SA), and temperature coefficient, and **guaranteed** maximum supply current. All improvements are highlighted in the electrical characteristics section. **All critical parameters are guaranteed over the entire commercial and industrial temperature ranges.**

### Pinout

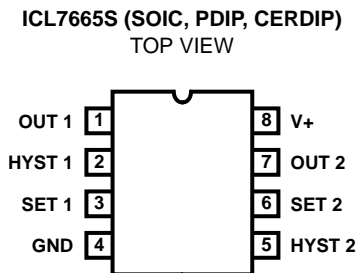

### Ordering Information

PART NUMBER	TEMPERATURE RANGE	PACKAGE
ICL7665SCBA	0 $^{\circ}$ to +70 $^{\circ}$ C	8 Lead SOIC (N)
ICL7665SCPA		8 Lead Plastic DIP
ICL7665SCJA		8 Lead CerDIP
ICL7665SACBA		8 Lead SOIC (N)
ICL7665SACPA		8 Lead Plastic DIP
ICL7665SACJA		8 Lead CerDIP
ICL7665SIBA	-40 $^{\circ}$ C to +85 $^{\circ}$ C	8 Lead SOIC (N)
ICL7665SIPA		8 Lead Plastic DIP
ICL7665SIJA		8 Lead CerDIP
ICL7665SAIBA		8 Lead SOIC (N)
ICL7665SAIPA		8 Lead Plastic DIP
ICL7665SAIJA		8 Lead CerDIP

# Specifications ICL7665S

## Absolute Maximum Ratings

Supply Voltage (Note 2)	-0.3 to +18V
Output Voltages OUT1 and OUT2 (with respect to GND) (Note 2)	-0.3V to 18V
Output Voltages HYST1 and HYST2 (with respect to V+) (Note 2)	-0.3V to +18V
Input Voltages SET1 and SET2 (Note 2)	(GND-0.3V) to (V+ V- +0.3V)
Maximum Sink Output OUT1 and OUT2	.25mA
Maximum Source Output Current HYST1 and HYST2	-25mA

## Thermal Information

Thermal Resistance	$\theta_{JA}$	$\theta_{JC}$
Ceramic DIP Package	115°C/W	30°C/W
Plastic DIP Package	150°C/W	-
Plastic SOIC Package	180°C/W	-
Maximum Junction Temperature (Plastic)	+150°C	
Maximum Junction Temperature (CerDIP)	+175°C	
Storage Temperature Range	-65°C to +150°C	
Lead Temperature (Soldering 10s) (SOIC - Lead Tips Only)	+300°C	

*CAUTION: Stresses above those listed in "Absolute Maximum Ratings" may cause permanent damage to the device. This is a stress only rating and operation of the device at these or any other conditions above those indicated in the operational sections of this specification is not implied.*

## Operating Conditions

Operating Temperature Range	ICL7665SC	ICL7665SI
	0°C to +70°C	-40°C to +85°C

**Electrical Specifications** The specifications below are applicable to both the ICL7665S and ICL7665SA. V+ = 5V, T<sub>A</sub> = +25°C, Test Circuit Figure 7. Unless Otherwise Specified

PARAMETER	SYMBOL	TEST CONDITIONS	MIN	TYP	MAX	UNITS	
Operating Supply Voltage	V+	ICL7665S	T <sub>A</sub> = +25°C	1.6	-	16	V
			0°C ≤ T <sub>A</sub> ≤ +70°C	1.8	-	16	V
			-25°C ≤ T <sub>A</sub> ≤ +85°C	1.8	-	16	V
		ICL7665SA	0°C ≤ T <sub>A</sub> ≤ +70°C	1.8	-	16	V
			-25°C ≤ T <sub>A</sub> ≤ +85°C	1.8	-	16	V
Supply Current	I+	GND ≤ V <sub>SET1</sub> , V <sub>SET2</sub> ≤ V+, All Outputs Open Circuit					
		0°C ≤ T <sub>A</sub> ≤ +70°C	V+ = 2V	-	2.5	10	μA
			V+ = 9V	-	2.6	10	μA
			V+ = 15V	-	2.9	10	μA
		-40°C ≤ T <sub>A</sub> ≤ +85°C	V+ = 2V	-	2.5	10	μA
			V+ = 9V	-	2.6	10	μA
			V+ = 15V	-	2.9	10	μA
Input Trip Voltage	V <sub>SET1</sub>	ICL7665S	1.20	1.30	1.40	V	
	V <sub>SET2</sub>		1.20	1.30	1.40	V	
	V <sub>SET1</sub>	ICL7665SA	1.275	1.30	1.325	V	
	V <sub>SET2</sub>		1.275	1.30	1.325	V	
Temperature Coefficient of V <sub>SET</sub>	$\frac{\Delta V_{SET}}{\Delta T}$	ICL7665S	-	200	-	ppm	
		ICL7665SA	-	100	-	ppm	
Supply Voltage Sensitivity of V <sub>SET1</sub> , V <sub>SET2</sub>	$\frac{\Delta V_{SET}}{\Delta V_S}$	R <sub>OUT1</sub> , R <sub>OUT2</sub> , R <sub>HYST1</sub> , R <sub>2HYST2</sub> = 1MΩ, 2V ≤ V+ ≤ 10V	-	0.03	-	%/V	
Output Leakage Currents of OUT and HYST	I <sub>OLK</sub>	V <sub>SET</sub> = 0V or V <sub>SET</sub> ≥ 2V	-	10	200	nA	
	I <sub>HLK</sub>		-	-10	-100	nA	
	I <sub>OLK</sub>	V+ = 15V, T <sub>A</sub> = +70°C	-	-	2000	nA	
	I <sub>HLK</sub>		-	-	-500	nA	
Output Saturation Voltages	V <sub>OUT1</sub>	V <sub>SET1</sub> = 2V, I <sub>OUT1</sub> = 2mA	V+ = 2V	-	0.2	0.5	V
			V+ = 5V	-	0.1	0.3	V
			V+ = 15V	-	0.06	0.2	V

## Specifications ICL7665S

**Electrical Specifications** The specifications below are applicable to both the ICL7665S and ICL7665SA.  $V_+ = 5V$ ,  $T_A = +25^\circ\text{C}$ , Test Circuit Figure 7. Unless Otherwise Specified **(Continued)**

PARAMETER	SYMBOL	TEST CONDITIONS	MIN	TYP	MAX	UNITS	
Output Saturation Voltages	$V_{HYST1}$	$V_{SET1} = 2V$ , $I_{HYST1} = -0.5mA$	$V_+ = 2V$	-	-0.15	-0.30	V
			$V_+ = 5V$	-	-0.05	-0.15	V
			$V_+ = 15V$	-	-0.02	-0.10	V
Output Saturation Voltages	$V_{OUT2}$	$V_{SET2} = 0V$ , $I_{OUT2} = 2mA$	$V_+ = 2V$	-	0.2	0.5	V
			$V_+ = 5V$	-	0.15	0.3	V
			$V_+ = 15V$	-	0.11	0.25	V
Output Saturation Voltages	$V_{HYST2}$	$V_{SET2} = 2V$	$V_+ = 2V$ , $I_{HYST2} = -0.2mA$	-	-0.25	-0.8	V
			$V_+ = 5V$ , $I_{HYST2} = -0.5mA$	-	-0.43	-1.0	V
			$V_+ = 15V$ , $I_{HYST2} = -0.5mA$	-	-0.35	-0.8	V
$V_{SET}$ Input Leakage Current	$I_{SET}$	$GND \leq V_{SET} \leq V_+$	-	0.01	10	nA	
$\Delta$ Input for Complete Output Change	$\Delta V_{SET}$	$R_{OUT} = 4.7k\Omega$ , $R_{HYST} = 20k\Omega$ , $V_{OUTLO} = 1\% V_+$ , $V_{OUTHl} = 99\% V_+$	ICL7665S	-	1.0	-	mV
			ICL7665SA	-	0.1	-	mV
Difference in Trip Voltages	$V_{SET1} - V_{SET2}$	$R_{OUT}$ , $R_{HYST} = 1mW$	-	$\pm 5$	$\pm 50$	mV	
Output/Hysteresis Difference		$R_{OUT}$ , $R_{HYST} = 1mW$	ICL7665S	-	$\pm 1$	-	mV
			ICL7665SA	-	$\pm 0.1$	-	mV

**NOTES:**

- Derate above  $+25^\circ\text{C}$  ambient temperature at  $4mW/^\circ\text{C}$
- Due to the SCR structure inherent in the CMOS process used to fabricate these devices, connecting any terminal to voltages greater than ( $V_+ + 0.3V$ ) or less than ( $GND - 0.3V$ ) may cause destructive device latchup. For these reasons, it is recommended that no inputs from external sources not operating from the same power supply be applied to the device before its supply is established, and that in multiple supply systems, the supply to the ICL7665S be turned on first. If this is not possible, current into inputs and/or outputs must be limited to  $\pm 0.5mA$  and voltages must not exceed those defined above.
- All significant improvements over the industry standard ICL7665 are highlighted.

### AC Electrical Specifications

PARAMETER	SYMBOL	TEST CONDITIONS	MIN	TYP	MAX	UNITS
<b>OUTPUT DELAY TIMES</b>						
Input Going HI	$t_{S01D}$	$V_{SET}$ Switched between 1.0V to 1.6V $R_{OUT} = 4.7k\Omega$ , $C_L = 12pF$ $R_{HYST} = 20k\Omega$ , $C_L = 12pF$	-	85	-	$\mu s$
	$t_{SH1D}$		-	90	-	$\mu s$
	$t_{S02D}$		-	55	-	$\mu s$
	$t_{SH2D}$		-	55	-	$\mu s$
Input Going LO	$t_{\bar{S}01D}$	$V_{SET}$ Switched between 1.6V to 1.0V $R_{OUT} = 4.7k\Omega$ , $C_L = 12pF$ $R_{HYST} = 20k\Omega$ , $C_L = 12pF$	-	75	-	$\mu s$
	$t_{\bar{S}H1D}$		-	80	-	$\mu s$
	$t_{\bar{S}02D}$		-	60	-	$\mu s$
	$t_{\bar{S}H2D}$		-	60	-	$\mu s$
Output Rise Times	$t_{O1R}$	$V_{SET}$ Switched between 1.0V to 1.6V $R_{OUT} = 4.7k\Omega$ , $C_L = 12pF$ $R_{HYST} = 20k\Omega$ , $C_L = 12pF$	-	0.6	-	$\mu s$
	$t_{O2R}$		-	0.8	-	$\mu s$
	$t_{H1R}$		-	7.5	-	$\mu s$
	$t_{H2R}$		-	0.7	-	$\mu s$

# Specifications ICL7665S

## AC Electrical Specifications (Continued)

PARAMETER	SYMBOL	TEST CONDITIONS	MIN	TYP	MAX	UNITS
Output Fall Times	$t_{O1F}$	$V_{SET}$ Switched between 1.0V to 1.6V $R_{OUT} = 4.7k\Omega$ , $C_L = 12pF$ $R_{HYST} = 20k\Omega$ , $C_L = 12pF$	-	0.6	-	$\mu s$
	$t_{O2F}$		-	0.7	-	$\mu s$
	$t_{H1F}$		-	4.0	-	$\mu s$
	$t_{H2F}$		-	1.8	-	$\mu s$

## Functional Block Diagram

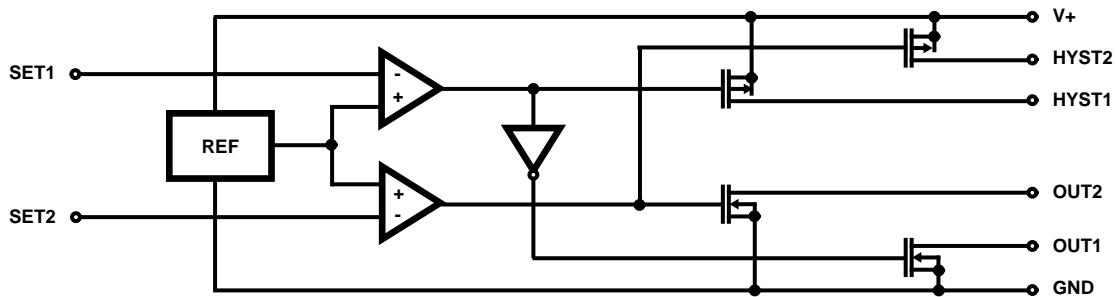

### CONDITIONS (Note 1)

$V_{SET1} > 1.3V$ , OUT1 Switch ON, HYST1 Switch ON  
 $V_{SET1} < 1.3V$ , OUT1 Switch OFF, HYST1 Switch OFF  
 $V_{SET2} > 1.3V$ , OUT2 Switch OFF, HYST2 Switch ON  
 $V_{SET2} < 1.3V$ , OUT2 Switch ON, HYST2 Switch OFF

### NOTE:

- See Electrical Specifications for exact thresholds.

## Typical Performance Curves

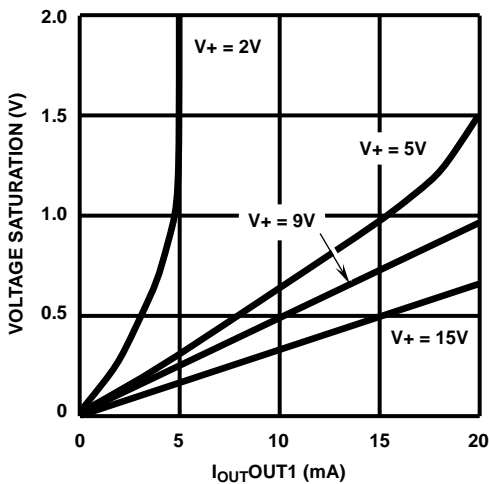

FIGURE 1. OUT1 SATURATION VOLTAGE AS A FUNCTION OF OUTPUT CURRENT

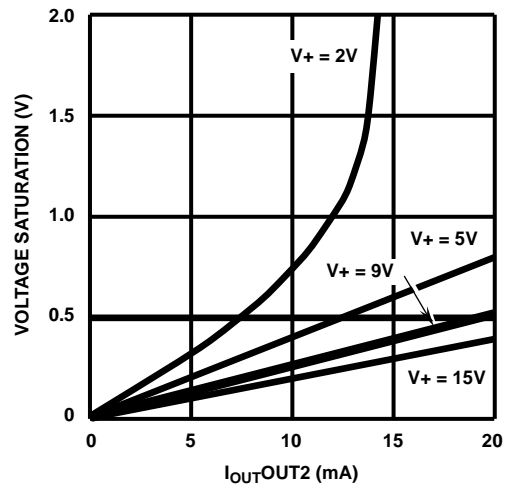

FIGURE 2. OUT2 SATURATION VOLTAGE AS A FUNCTION OF OUTPUT CURRENT

Typical Performance Curves

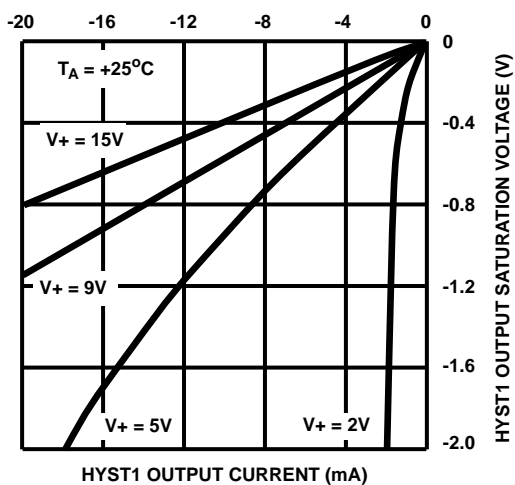

FIGURE 3. HYST1 OUTPUT SATURATION VOLTAGE vs HYST1 OUTPUT CURRENT

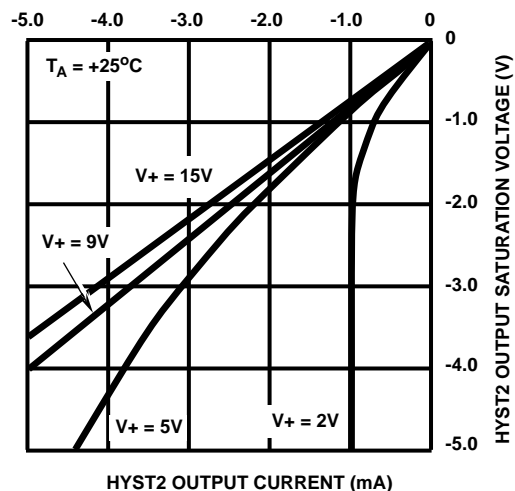

FIGURE 4. HYST2 OUTPUT SATURATION VOLTAGE vs HYST2 OUTPUT CURRENT

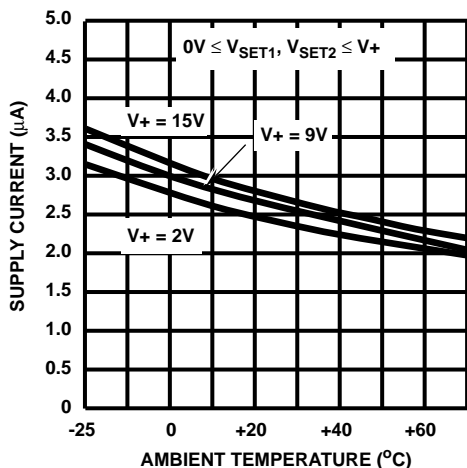

FIGURE 5. SUPPLY CURRENT AS A FUNCTION OF AMBIENT TEMPERATURE

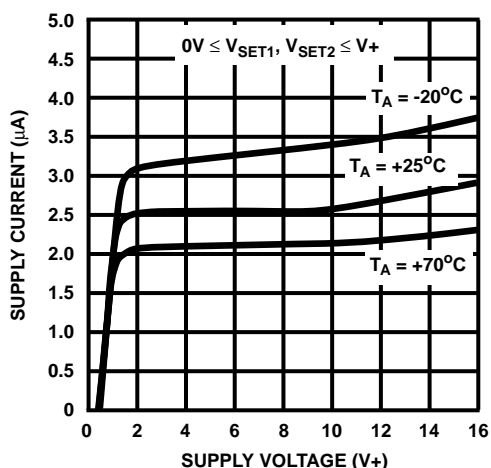

FIGURE 6. SUPPLY CURRENT AS A FUNCTION OF SUPPLY VOLTAGE

### Detailed Description

As shown in the Functional Diagram, the ICL7665S consists of two comparators which compare input voltages on the SET1 and SET2 terminals to an internal 1.3V bandgap reference. The outputs from the two comparators drive open-drain N-channel transistors for OUT1 and OUT2, and open-drain P-channel transistors for HYST1 and HYST2 outputs. Each section, the Under Voltage Detector and the Over Voltage Detector, is independent of the other, although both use the internal 1.3V reference. The offset voltages of the two comparators will normally be unequal so  $V_{SET1}$  will generally not quite equal  $V_{SET2}$ .

The input impedance of the SET1 and SET2 pins are extremely high, and for most practical applications can be ignored. The four outputs are open-drain MOS transistors, and when ON behave as low resistance switches to their respective supply rails. This minimizes errors in setting up the hysteresis, and maximizes the output flexibility. The operating currents of the bandgap reference and the comparators are around 100nA each.

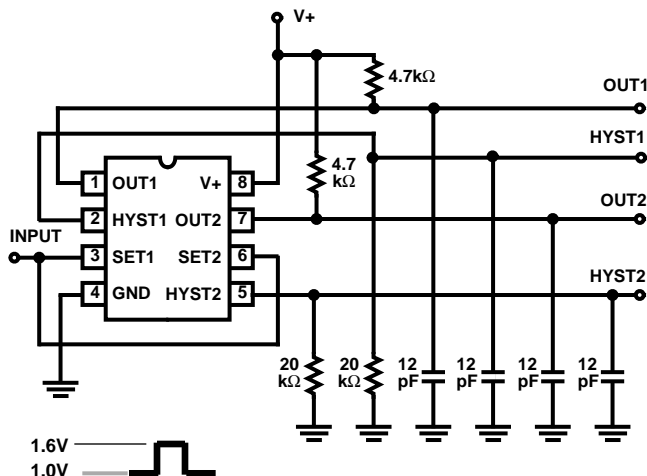

FIGURE 7. TEST CIRCUITS

### Precautions

Junction isolated CMOS devices like the ICL7665S have an inherent SCR or 4-layer PNP structure distributed throughout the die. Under certain circumstances, this can be triggered into a potentially destructive high current mode. This latchup can be triggered by forward-biasing an input or output with respect to the power supply, or by applying excessive supply voltages. In very low current analog circuits, such as the ICL7665S, this SCR can also be triggered by applying the input power supply extremely rapidly (“instantaneously”), e.g. through a low impedance battery and an ON/OFF switch with short lead lengths. The rate-of-rise of the supply voltage can exceed 100V/μs in such a circuit. A low impedance capacitor (e.g., 0.05μF disc ceramic)

between the V+ and GND pins of the ICL7665S can be used to reduce the rate-of-rise of the supply voltage in battery applications. In line operated systems, the rate-of-rise of the supply is limited by other considerations, and is normally not a problem.

If the SET voltages must be applied before the supply voltage V+, the input current should be limited to less than 0.5mA by appropriate external resistors, usually required for voltage setting anyway. A similar precaution should be taken with the outputs if it is likely that they will be driven by other circuits to levels outside the supplies at any time.

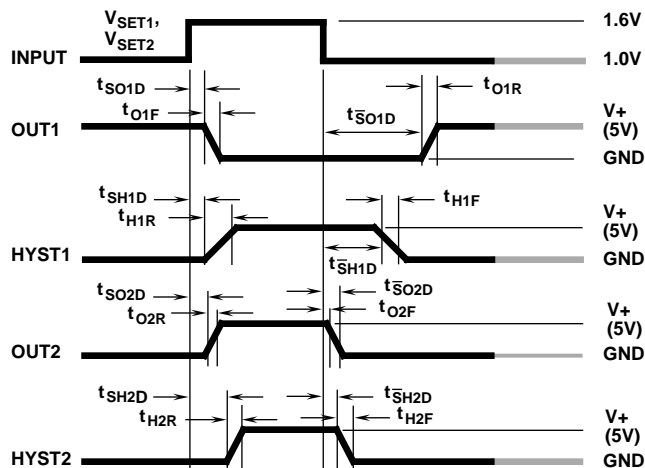

FIGURE 8. SWITCHING WAVEFORMS

### Simple Threshold Detector

Figure 9 shows the simplest connection of the ICL7665S for threshold detection. From the graph 9B, it can be seen that at low input voltage OUT1 is OFF, or high, while OUT2 is ON, or low. As the input rises (e.g., at power-on) toward  $V_{NOM}$  (usually the eventual operating voltage), OUT2 goes high on reaching  $V_{TR2}$ . If the voltage rises above  $V_{NOM}$  as much as  $V_{TR1}$ , OUT1 goes low. The equation giving  $V_{SET1}$  and  $V_{SET2}$  are from Figure 9A:

$$V_{SET1} = V_{IN} \frac{R_{11}}{(R_{11} + R_{21})} ; V_{SET2} = V_{IN} \frac{R_{12}}{(R_{12} + R_{22})}$$

Since the voltage to trip each comparator is nominally 1.3V, the value  $V_{IN}$  for each trip point can be found from

$$V_{TR1} = V_{SET1} \frac{(R_{11} + R_{21})}{R_{11}} = 1.3 \frac{(R_{11} + R_{21})}{R_{11}} \quad \text{for detector 1}$$

and

$$V_{TR2} = V_{SET2} \frac{(R_{12} + R_{22})}{R_{12}} = 1.3 \frac{(R_{12} + R_{22})}{R_{12}} \quad \text{for detector 2}$$

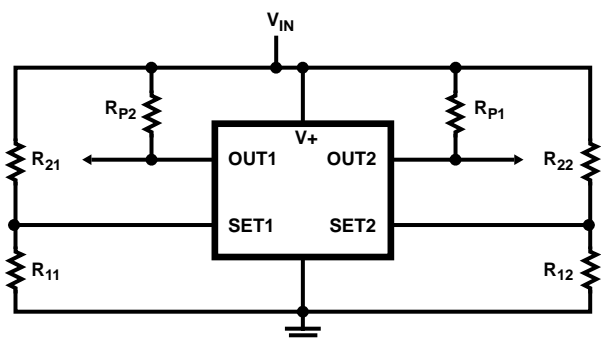

FIGURE 9A. CIRCUIT CONFIGURATION

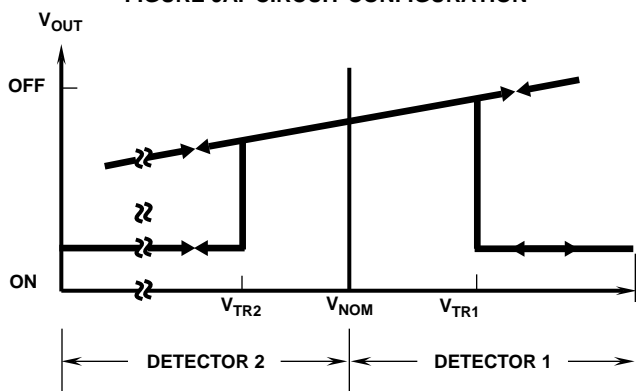

FIGURE 9B. TRANSFER CHARACTERISTICS

FIGURE 9. SIMPLE THRESHOLD DETECTOR

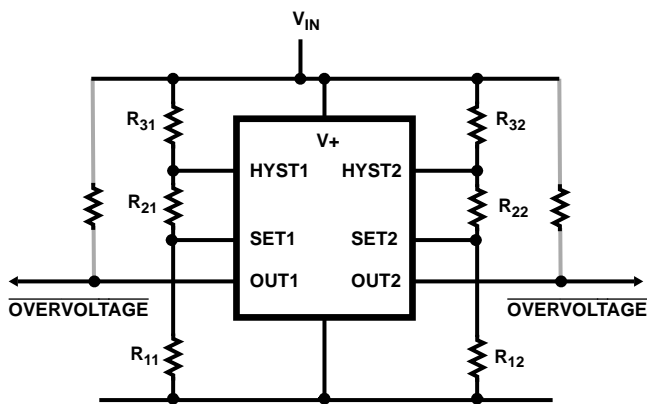

FIGURE 10A. CIRCUIT CONFIGURATION

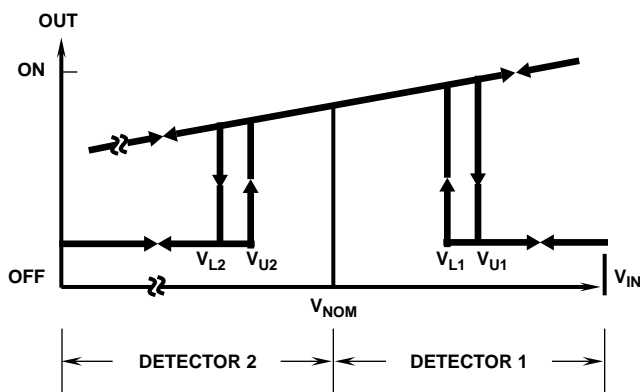

FIGURE 10B. TRANSFER CHARACTERISTICS

FIGURE 10. THRESHOLD DETECTOR WITH HYSTERESIS

Either detector may be used alone, as well as both together, in any of the circuits shown here.

When  $V_{IN}$  is very close to one of the trip voltage, normal variations and noise may cause it to wander back and forth across this level, leading to erratic output ON and OFF conditions. The addition of hysteresis, making the trip points slightly different for rising and falling inputs, will avoid this condition.

### Threshold Detector with Hysteresis

Figure 10A shows how to set up such hysteresis, while Figure 10B shows how the hysteresis around each trip point produces switching action at different points depending on whether  $V_{IN}$  is rising or falling (the arrows indicated direction of change). The HYST outputs are basically switches which short out  $R_{31}$  or  $R_{32}$  when  $V_{IN}$  is above the respective trip point. Thus if the input voltage rises from a low value, the trip point will be controlled by  $R_{1N}$ ,  $R_{2N}$ , and  $R_{3N}$ , until the trip point is reached. As this value is passed, the detector changes state,  $R_{3N}$  is shorted out, and the trip point becomes controlled by only  $R_{1N}$  and  $R_{2N}$ , a lower value. The input will then have to fall to this new point to restore the initial comparator state, but as soon as this occurs, the trip point will be raised again.

An alternative circuit for obtaining hysteresis is shown in Figure 11. In this configuration, the HYST pins put the extra resistor in parallel with the upper setting resistor. The values of the resistors differ, but the action is essentially the same. The governing equations are given in Table 1. These ignore the effects of the resistance of the HYST outputs, but these can normally be neglected if the resistor values are above about 100kΩ.

$$V_{TR2} = V_{SET2} \frac{(R_{12} + R_{22})}{R_{12}} = 1.3 \frac{(R_{12} + R_{22})}{R_{12}} \text{ for detector 2}$$

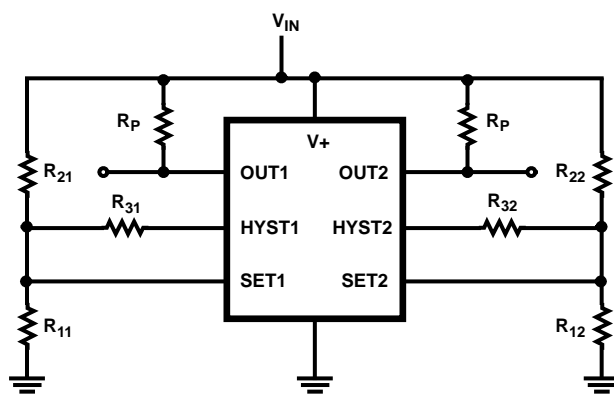

FIGURE 11. AN ALTERNATIVE HYSTERESIS CIRCUIT

TABLE 1. SET-POINT EQUATIONS

NO HYSTERESIS	
Over-Voltage $V_{TRIP}$	$= \frac{R_{11} + R_{21}}{R_{11}} \times V_{SET1}$
Over-Voltage $V_{TRIP}$	$= \frac{R_{12} + R_{22}}{R_{12}} \times V_{SET2}$
HYSTERESIS PER FIGURE 10A	
$V_{U1}$	$= \frac{R_{11} + R_{21} + R_{31}}{R_{11}} \times V_{SET1}$
Over-Voltage $V_{TRIP}$	
$V_{L1}$	$= \frac{R_{11} + R_{21}}{R_{11}} \times V_{SET1}$
$V_{U2}$	$= \frac{R_{12} + R_{22} + R_{32}}{R_{12}} \times V_{SET2}$
Under-Voltage $V_{TRIP}$	
$V_{L2}$	$= \frac{R_{12} + R_{22}}{R_{12}} \times V_{SET2}$
HYSTERESIS PER FIGURE 11	
$V_{U1}$	$= \frac{R_{11} + R_{21}}{R_{11}} \times V_{SET1}$
Over-Voltage $V_{TRIP}$	
$V_{L1}$	$= \frac{R_{11} + \frac{R_{21}R_{31}}{R_{21} + R_{31}}}{R_{11}} \times V_{SET1}$
$V_{U2}$	$= \frac{R_{12} + R_{22}}{R_{12}} \times V_{SET2}$
Over-Voltage $V_{TRIP}$	
$V_{L2}$	$= \frac{R_{12} + \frac{R_{22}R_{32}}{R_{22} + R_{32}}}{R_{12}} \times V_{SET2}$

**Applications**

**Single Supply Fault Monitor**

Figure 12 shows an over/under voltage fault monitor for a single supply. The over voltage trip point is centered around 5.5V and the under voltage trip point is centered around 4.5V. Both have some hysteresis to prevent erratic output ON and OFF conditions. The two outputs are connected in a wired OR configuration with a pullup resistor to generate a power OK signal.

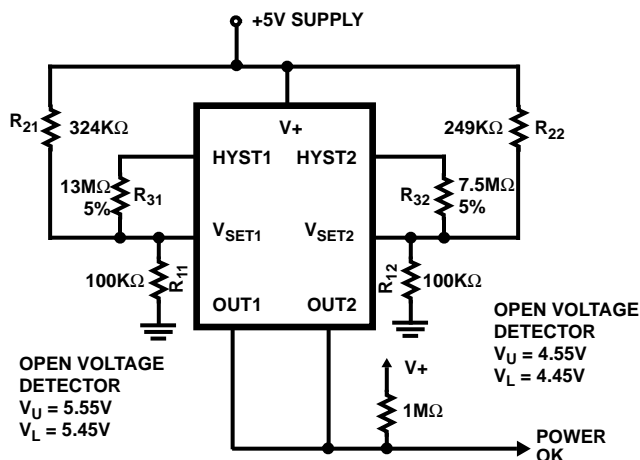

FIGURE 12. FAULT MONITOR FOR A SINGLE SUPPLY

**Multiple Supply Fault Monitor**

The ICL7665S can simultaneously monitor several supplies when connected as shown in Figure 13. The resistors are chosen such that the sum of the currents through  $R_{21A}$ ,  $R_{21B}$ , and  $R_{31}$  is equal to the current through  $R_{11}$  when the two input voltage are at the desired low voltage detection point. The current through  $R_{11}$  at this point is equal to  $1.3V/R_{11}$ . The voltage at the  $V_{SET}$  input depends on the voltage of both supplies being monitored. The trip voltage of one supply while the other supply is at the nominal voltage will be different that the trip voltage when both supplies are below their nominal voltages.

The other side of the ICL7665S can be used to detect the absence of negative supplies. The trip points for OUT1 depend on both the negative supply voltages and the actual voltage of the +5V supply.

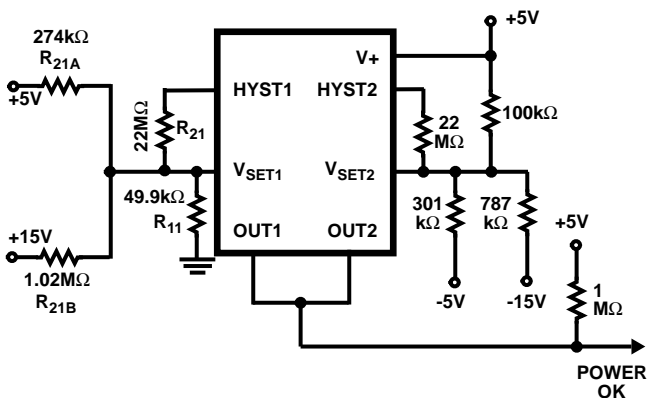

FIGURE 13. MULTIPLE SUPPLY FAULT MONITOR





## ICL7665S

### Simple High/Low Temperature Alarm

Figure 16 illustrates a simple high/low temperature alarm which uses the ICL7665S with an NPN transistor. The voltage at the top of  $R_1$  is determined by the  $V_{BE}$  of the transistor and the position of  $R_1$ 's wiper arm. This voltage has a negative temperature coefficient.  $R_1$  is adjusted so that  $V_{SET2}$  equals 1.3V when the NPN transistor's temperature reaches the temperature selected for the high temperature alarm. When this occurs, OUT2 goes low.  $R_2$  is adjusted so that  $V_{SET1}$  equals 1.3V when the NPN transistor's temperature reaches the temperature selected for the low temperature alarm. When the temperature drops below this limit, OUT1 goes low.

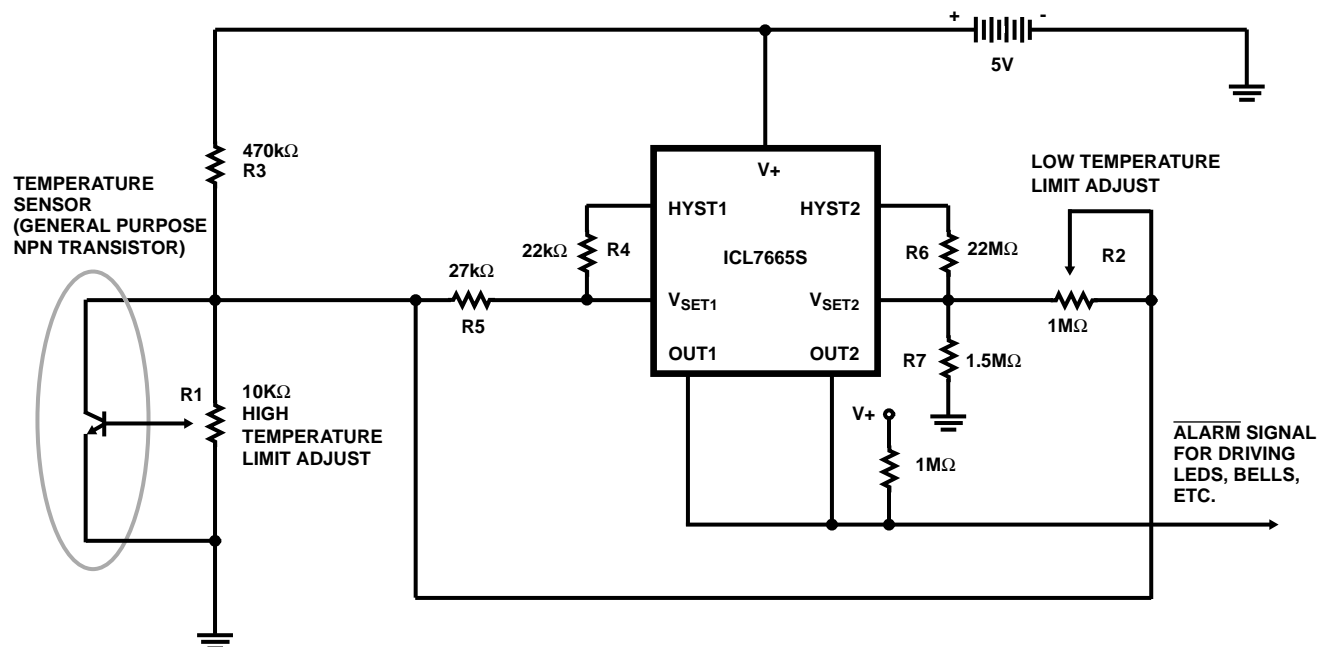

FIGURE 16. SIMPLE HIGH/LOW TEMPERATURE ALARM

### AC Power Fail and Brownout Detector

Figure 17 shows a circuit that detects AC undervoltage by monitoring the secondary side of the transformer. The capacitor,  $C_1$ , is charged through  $R_1$  when OUT1 is OFF. With a normal 100 VAC input to the transformer, OUT1 will discharge  $C_1$  once every cycle, approximately every 16.7ms. When the AC input voltage is reduced, OUT1 will stay OFF, so that  $C_1$  does not discharge. When the voltage on  $C_1$  reaches 1.3V, OUT2 turns OFF and the power fail warning goes high. The time constant,  $R_1C_1$ , is chosen such that it takes longer than 16.7ms to charge  $C_1$  1.3V.

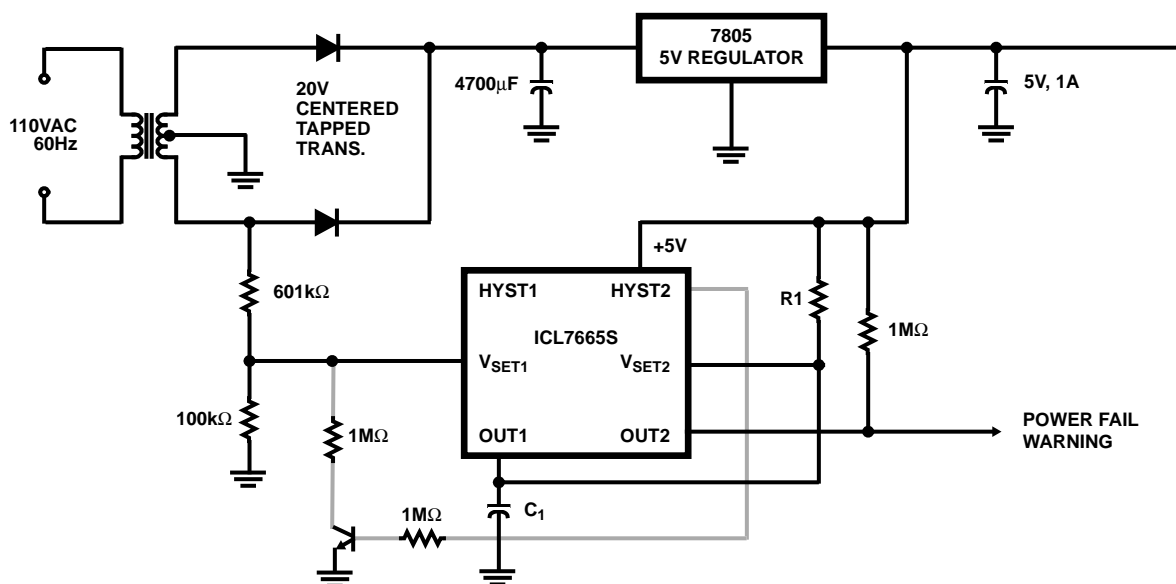

FIGURE 17. AC POWER FAIL AND BROWNOUT DETECTOR